

BSA3-BD and BSA6-BD Bellows Sealed Stop Valves

Installation and Maintenance Instructions

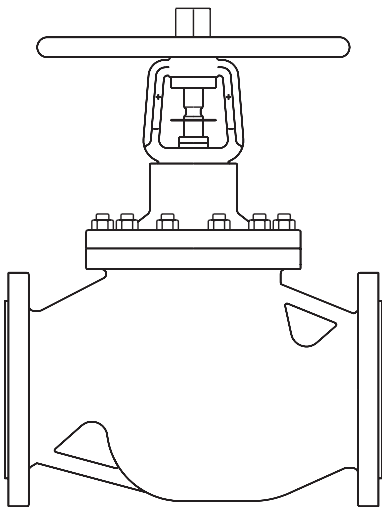

DN300 shown

1. Safety information
2. General product information
3. Installation
4. Commissioning
5. Operation
6. Maintenance and spare parts

1. Safety information

Safe operation of these products can only be guaranteed if they are properly installed, commissioned, used and maintained by qualified personnel (see Section 1.11) in compliance with the operating instructions. General installation and safety instructions for pipeline and plant construction, as well as the proper use of tools and safety equipment must also be complied with.

1.1 Intended use

Referring to the Installation and Maintenance Instructions, name-plate and Technical Information Sheet, check that the product is suitable for the intended use/application.

The products listed below comply with the requirements of the EU Pressure Equipment Directive

/ UK Pressure Equipment (Safety) Regulations and each carries the  mark when so required.

The products fall within the following Pressure Equipment Directive (PED) categories:

Product		Group 1 Gases	Group 2 Gases	Group 1 Liquids	Group 2 Liquids
PN16	DN200	2	1	2	SEP
	DN250 - DN300	3	2	2	SEP
	DN350 - DN400	3	3	2	1
BSA3-BD PN25	DN200	3	2	2	SEP
	DN250	3	2	2	1
	DN300 - DN400	3	3	2	1
PN40	DN200	3	2	2	SEP
	DN250	3	2	2	1
	DN300 - DN400	3	3	2	1
BSA6-DB	DN125	2	1	2	SEP
	DN150 - DN200	2	1	2	SEP
	DN125	2	1	2	SEP
	DN150 - DN200	2	1	2	SEP

- i) The product has been specifically designed for use on steam, compressed air, water/condensate which are in Group 2 of the above mentioned Pressure Equipment Directive.
- ii) A number of products are supplied for the intention of the end user (or agent thereof) modifying the flange configuration from that supplied. It is the responsibility of the organisation carrying out the modification to do so in accordance with the internationally recognised flange standards and to ensure that the design rating and operation of the product are not compromised. Spirax Sarco will not be held responsible for any unapproved modification or consequential liability resulting in failure to observe these requirements.
- iii) Determine the correct installation situation and direction of fluid flow.
- iv) Spirax Sarco products are not intended to withstand external stresses that may be induced by any system to which they are fitted. It is the responsibility of the installer to consider these stresses and take adequate precautions to minimise them.
- v) Remove protection covers from all connections and protective film from all name-plates, where appropriate, before installation on steam or other high temperature applications.

1.2 Access

Ensure safe access and if necessary a safe working platform (suitably guarded) before attempting to work on the product. Arrange suitable lifting gear if required.

1.3 Lighting

Ensure adequate lighting, particularly where detailed or intricate work is required.

1.4 Hazardous liquids or gases in the pipeline

Consider what is in the pipeline or what may have been in the pipeline at some previous time. Consider: flammable materials, substances hazardous to health, extremes of temperature.

1.5 Hazardous environment around the product

Consider: explosion risk areas, lack of oxygen (e.g. tanks, pits), dangerous gases, extremes of temperature, hot surfaces, fire hazard (e.g. during welding), excessive noise, moving machinery.

1.6 The system

Consider the effect on the complete system of the work proposed. Will any proposed action (e.g. closing isolation valves, electrical isolation) put any other part of the system or any personnel at risk? Dangers might include isolation of vents or protective devices or the rendering ineffective of controls or alarms. Ensure isolation valves are turned on and off in a gradual way to avoid system shocks.

1.7 Pressure systems

Ensure that any pressure is isolated and safely vented to atmospheric pressure. Consider double isolation (double block and bleed) and the locking or labelling of closed valves. Do not assume that the system has depressurised even when the pressure gauge indicates zero.

1.8 Temperature

Allow time for temperature to normalise after isolation to avoid the danger of burns.

1.9 Tools and consumables

Before starting work ensure that you have suitable tools and/or consumables available. Use only genuine Spirax Sarco replacement parts.

1.10 Protective clothing

Consider whether you and/or others in the vicinity require any protective clothing to protect against the hazards of, for example, chemicals, high/low temperature, radiation, noise, falling objects, and dangers to eyes and face.

1.11 Permits to work

All work must be carried out or be supervised by a suitably competent person.

Installation and operating personnel should be trained in the correct use of the product according to the Installation and Maintenance Instructions.

Where a formal 'permit to work' system is in force it must be complied with. Where there is no such system, it is recommended that a responsible person should know what work is going on and, where necessary, arrange to have an assistant whose primary responsibility is safety.

Post 'warning notices' if necessary.

1.12 Handling

Manual handling of large and/or heavy products may present a risk of injury. Lifting, pushing, pulling, carrying or supporting a load by bodily force can cause injury particularly to the back. You are advised to assess the risks taking into account the task, the individual, the load and the working environment and use the appropriate handling method depending on the circumstances of the work being done.

1.13 Residual hazards

In normal use the external surface of the product may be very hot. If used at the maximum permitted operating conditions the surface temperature of some products may reach temperatures in excess of 425 °C (797 °F).

Many products are not self-draining. Take due care when dismantling or removing the product from an installation (refer to 'Maintenance instructions').

1.14 Freezing

Provision must be made to protect products which are not self-draining against frost damage in environments where they may be exposed to temperatures below freezing point.

1.15 Safety information - Product specific

See the relevant Sections in the attached Installation and Maintenance Instructions for specific details relating to these products.

Warning

The body/bonnet collar gaskets contain a thin stainless steel support ring which may cause physical injury if they are not handled and disposed of carefully.

Care must be taken when opening and closing the handwheel to prevent any possible injury to the hands from the locking screw.

1.16 Disposal

Unless otherwise stated in the Installation and Maintenance Instructions, this product is recyclable and no ecological hazard is anticipated with its disposal providing due care is taken.

Please visit the Spirax Sarco product compliance web pages

<https://www.spiraxsarco.com/product-compliance>

for up to date information on any substances of concern that may be contained within this product.

Where no additional information is provided on the Spirax Sarco product compliance web page, this product may be safely recycled and/or disposed providing due care is taken. Always check your local recycling and disposal regulations.

1.17 Returning products

Customers and stockists are reminded that under EC Health, Safety and Environment Law, when returning products to Spirax Sarco they must provide information on any hazards and the precautions to be taken due to contamination residues or mechanical damage which may present a health, safety or environmental risk. This information must be provided in writing including Health and Safety data sheets relating to any substances identified as hazardous or potentially hazardous.

2. General product information

2.1 General description

A range of sealed, in-line stop valves having tri-ply bellows as standard throughout the range. These valves have been designed for use on steam, gas, liquid, thermal oils, condensate and water systems. The **BSA3-BD** is fitted with a flat, balanced pressure plug as standard.

The **BSA3-BD** and **BSA6-BD** are fitted with a flat, balanced pressure plug as standard.

Certification

The **BSA3-BD** and **BSA6-BD** body and bonnet are available with certification to EN 10204 3.1.

Note: All certification/inspection requirements must be stated at the time of order placement.

Note: For further technical information regarding this product range see TI-P184-18.

2.2 Sizes and pipe connections

BSA3-BD: DN200, DN250, DN300, DN350 and DN400 Flanged EN 1092 PN16, PN25 and PN40

BSA6-BD: DN125, DN150 and DN200 Flanged EN 1092 PN16 and PN25

2.3 BSA3-BD

Fig. 1
DN200 and DN250 BSA3-BD
bellows sealed stop valves

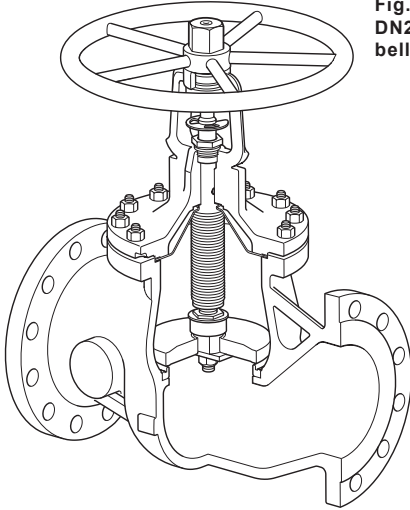
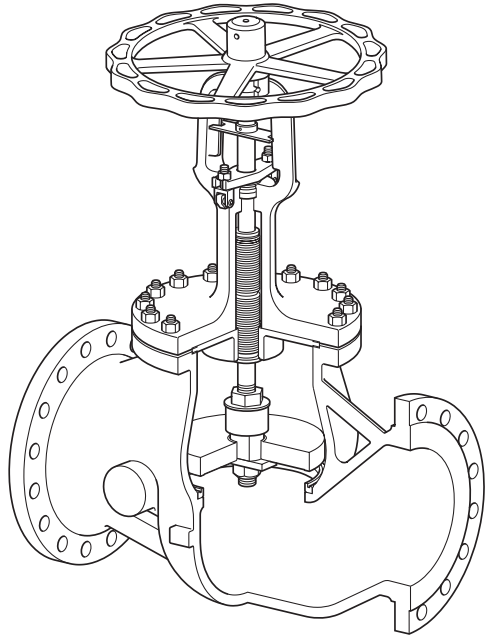
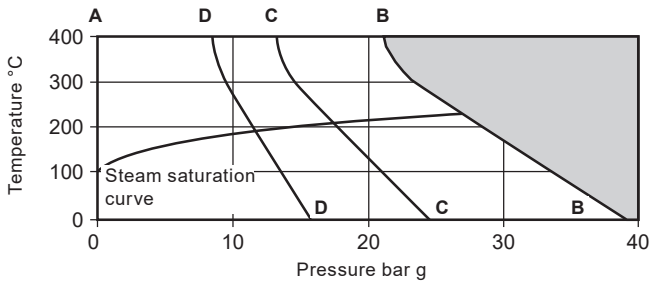

Fig. 2
DN300 to DN400 BSA3-BD
bellows sealed stop valves



Pressure/temperature limits - EN 12516-1



The product **must not** be used in this region or beyond the parameter of the PMA or TMA of the relative end connection.

A - B - B PN40

A - C - C PN25

A - D - D PN16

A - D - D	PN16	Body design condition	PN16	
		PMA	Maximum allowable pressure	15.6 bar g @ 0 °C
		TMA	Maximum allowable temperature	400 °C @ 8.4 bar g
			Minimum allowable temperature	-10 °C
		PMO	Maximum operating pressure for saturated steam service	11.6 bar g
		TMO	Maximum operating temperature	400 °C @ 8.4 bar g
			Minimum operating temperature	-10 °C
			Minimum operating pressure	0 bar g
			Maximum differential pressure is limited to the PMO	
			Designed for a maximum cold hydraulic test pressure of:	24 bar g
A - C - C	PN25	Body design condition	PN25	
		PMA	Maximum allowable pressure	24.4 bar g @ 0 °C
		TMA	Maximum allowable temperature	400 °C @ 13.2 bar g
			Minimum allowable temperature	-10 °C
		PMO	Maximum operating pressure for saturated steam service	17.5 bar g
		TMO	Maximum operating temperature	400 °C @ 13.2 bar g
			Minimum operating temperature	-10 °C
			Minimum operating pressure	0 bar g
			Maximum differential pressure is limited to the PMO	
			Designed for a maximum cold hydraulic test pressure of:	37.5 bar g
A - B - B	PN40	Body design condition	PN40	
		PMA	Maximum allowable pressure	39 bar g @ 0 °C
		TMA	Maximum allowable temperature	400 °C @ 21.1 bar g
			Minimum allowable temperature	-10 °C
		PMO	Maximum operating pressure for saturated steam service	26.8 bar g
		TMO	Maximum operating temperature	400 °C @ 21.1 bar g
			Minimum operating temperature	-10 °C
			Minimum operating pressure	0 bar g
			Maximum differential pressure is limited to the PMO	
			Designed for a maximum cold hydraulic test pressure of:	60 bar g

BSA3-BD and BSA6-BD Bellows Sealed Stop Valves

2.4 BSA6-BD

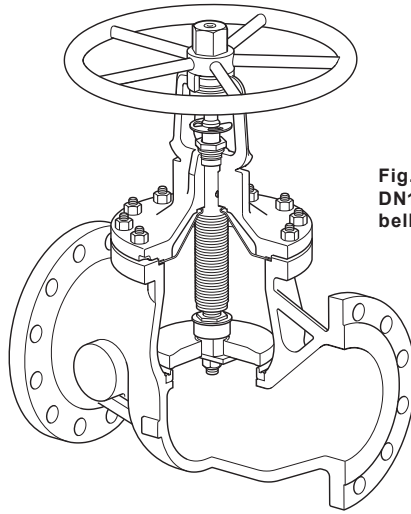
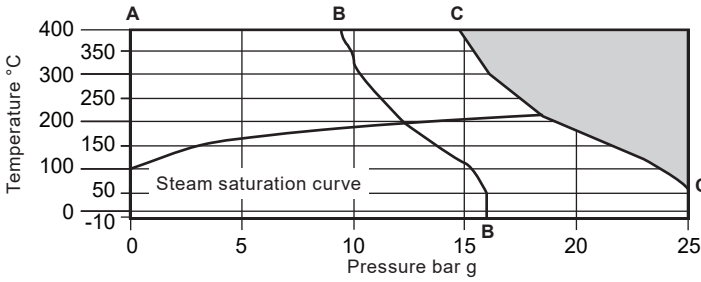

Fig. 3
DN125 to DN200 BSA6-BD
bellows sealed stop valves

Pressure/temperature limits - EN 12516-1



The product **must not** be used in this region or beyond the parameter of the PMA or TMA of the relative end connection.

A - B - B PN25

A - C - C PN16

	Body design condition	PN16
	PMA Maximum allowable pressure	16 bar g @ 50 °C
	TMA Maximum allowable temperature	400 °C @ 9.4 bar g
	Minimum allowable temperature	-10 °C
A - B - B	PN16	
	PMO Maximum operating pressure for saturated steam service	12.33 bar g
	TMO Maximum operating temperature	400 °C @ 9.4 bar g
	Minimum operating temperature	-10 °C
	Minimum operating pressure	0 bar g
	Maximum differential pressure is limited to the PMO	
	Designed for a maximum cold hydraulic test pressure of:	
	Body design condition	PN25
	PMA Maximum allowable pressure	25 bar g @ 50 °C
	TMA Maximum allowable temperature	400 °C @ 14.7 bar g
	Minimum allowable temperature	-10 °C
A - C - C	PN25	
	PMO Maximum operating pressure for saturated steam service	18.58 bar g
	TMO Maximum operating temperature	400 °C @ 14.7 bar g
	Minimum operating temperature	-10 °C
	Minimum operating pressure	0 bar g
	Maximum differential pressure is limited to the PMO	
	Designed for a maximum cold hydraulic test pressure of:	

2.5 Seat leakage

Disc to seat shut-off conforms to EN 12266-1 Rate A leakage.

2.6 Kv values

All **BSA3-BD** and **BSA6-BD** valves will be supplied with a balanced disc.

BSA3-BD				
DN200	DN250	DN300	DN350	DN400
593	935	1264	1804	2362

BSA6-BD		
DN125	DN150	DN200
205	295	562

For conversion:

C_v (UK) = $K_v \times 0.963$

C_v (US) = $K_v \times 1.156$

2.7 To convert Kv to volume flowrate in m³/h:

$$\dot{Q} = K_v \times \sqrt{\Delta P}$$

Where: \dot{Q} = Volume flow in cubic m/h

$\sqrt{\Delta P}$ = Pressure drop in bar

3. Installation

Note: Before actioning any installation observe the 'Safety information' in Section 1.

Referring to the Installation and Maintenance Instructions, name-plate and Technical Information Sheet, check that the product is suitable for the intended installation:

- 3.1** Check materials, pressure and temperature and their maximum values. If the maximum operating limit of the product is lower than that of the system in which it is being fitted, ensure that a safety device is included in the system to prevent overpressurisation.
- 3.2** Remove the protective covers from all connections.
- 3.3** Install the valve in the direction of flow given by the arrow on the body. The preferred position is with the spindle vertical. The valve can be installed from the vertical to the horizontal plane (see Figure 4).
- 3.5** When installed on steam systems a suitable steam trap should be fitted immediately upstream of the isolation valve to drain condensate. This will ensure drainage of the pipe when the valve is closed, and will prevent damage of the valve due to waterhammer. The drain trap should be either a ball float (FT) or thermodynamic (TD) type. Correct condensate drainage of all upstream pipework is also vital.
- 3.6** Always open isolation valves slowly to avoid system shocks.
- 3.7** **Note:** It is advisable that when work is being carried out downstream of a valve installation, double isolation (block and bleed) should be fitted. In addition when installed as the final valve in a pipeline, as a safety precaution, a blanking plate or blank flange must be fitted to the outlet flange of the valve.

4. Commissioning

After installation or maintenance ensure that the system is fully functioning. Carry out tests on any alarms or protective devices.

5. Operation

5.1 The bellows sealed isolation valve plays an important role in the conservation of energy by eliminating fugitive stem seal emissions.

5.2 The valve is operated manually by a handwheel. Special care must be taken to ensure that the movement is made in the correct direction.

To open the valve fully, it is recommended to turn the handwheel until the shaft is raised to the maximum position, indicated by the (+) on the bonnet, then turn the handwheel clockwise an 1 to ¼ turn to remove any backlash. This is to prevent the possibility of attempting to force open a valve, which is already fully open, resulting in damage to the stem, bellows unit or other components. Spirax Sarco BSA valves are fitted with a position indicator which can be found on the stem, and should align with the (+) or (-) on the bonnet support pillars. (+ = fully open/- = fully closed).

5.3 If valve 'keys' are used care must be taken not to use excessive force when opening or closing the valve.

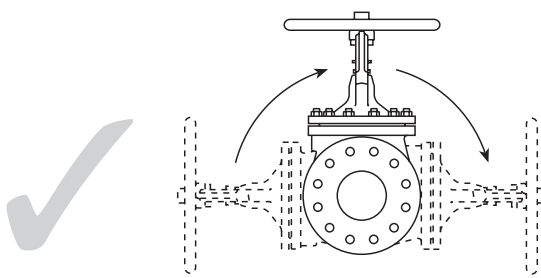

Correct installation

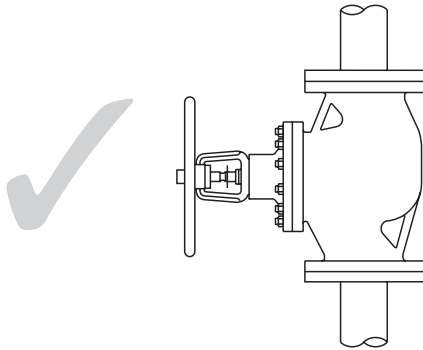

Correct installation

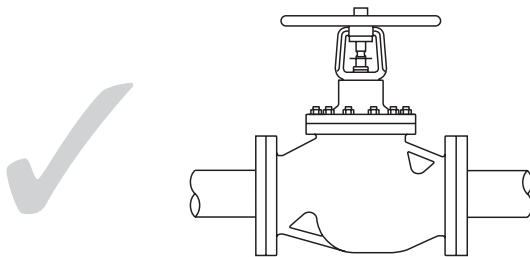

Correct installation

Incorrect installation

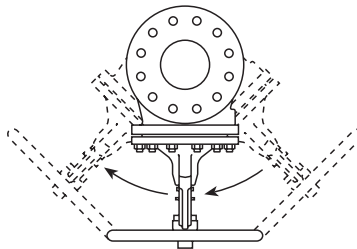

Fig. 4

6. Maintenance and spare parts

All the internals of the bellows sealed valve can be replaced

Note: Before actioning any maintenance programme observe the 'Safety information' in Section 1.

Warning

The body/bonnet collar gaskets (9) contain a thin stainless steel support ring which may cause physical injury if they are not handled and disposed of carefully.

6.1 Available spares

The spare parts available are shown in solid outline. Parts drawn in a grey line are not supplied as spares.

Available spares

Body / bonnet gasket and stem packing	15 and 9 (2 off)
Stem and bellows assembly	5, 6, 12, 14, 15 and 9 (2 off)
Disc (state full description of the valve)	4, 12, 13, 14, 15 and 9 (2 off)

How to order spares

Please note: for customer convenience spares are supplied in kits to ensure all the appropriate replacement parts are supplied to carry out a specific maintenance task. e.g. when a stem/bellows assembly is ordered, parts 5, 6, 12, 14, 15, and 9 (2 off) will be included in the kit.

Always order spares by using the description given in 'Available spares' and state the size and type of stop valve.

Example: 1 - Body/bonnet gasket and stem packing for a DN200 Spirax Sarco BSA3-BD PN40 bellows sealed stop valve.

6.2 Maintenance

Before undertaking any maintenance on the valve, ensure that any pressure is isolated and safely vented to atmospheric pressure. The valve should then be allowed to cool. When reassembling, ensure that all joint faces are clean.

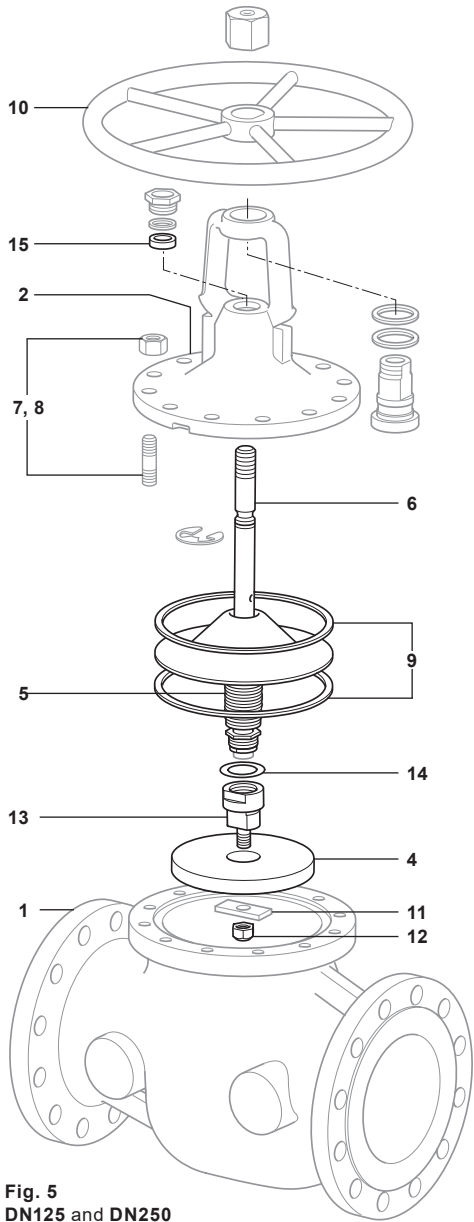

Fig. 5
DN125 and DN250

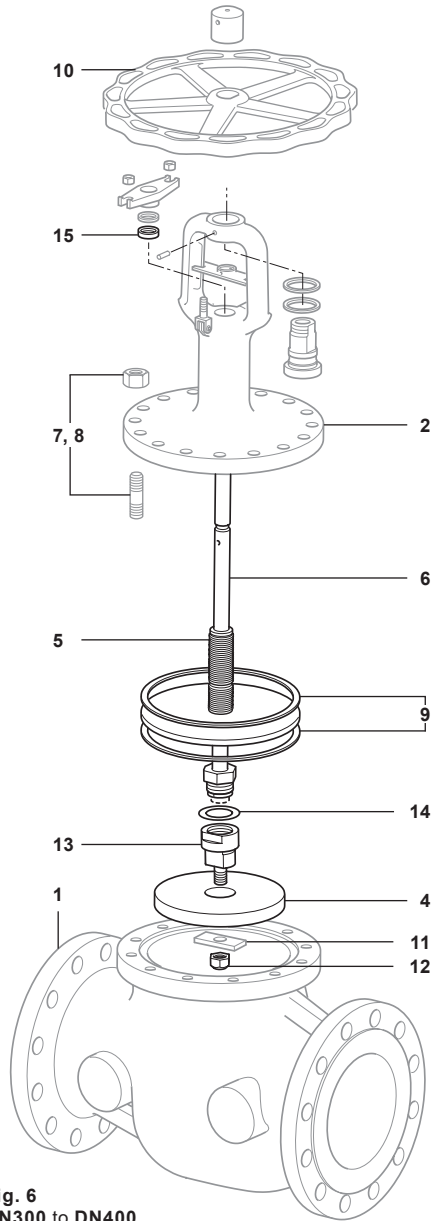

Fig. 6
DN300 to DN400

BSA3-BD and BSA6-BD Bellows Sealed Stop Valves

6.3 How to fit the body/bonnet gaskets

This can be carried out whilst the valve is connected in the pipeline. Remove the valve bonnet (2) from the body (1) by unscrewing bonnet studs/nuts (7, 8). The body gasket (9) is now visible and can quickly be replaced. Ensure the gasket face in the body (1) is clean before fitting a replacement.

To replace the second gasket (9) which is situated between the bonnet (2) and the stainless steel bellows support collar, firstly remove the clip-on position indicator. Rotate the handwheel (10) in a clockwise direction. This pushes the main stem (6) downwards and creates a gap between the bellows support collar and the bonnet (2). If the support collar remains attached to the bonnet (2), gently prise the collar away from the bonnet being careful not to damage the collar.

Do not allow the bellows to stretch as this can reduce the bellows life.

By continually rotating the handwheel (10) in a clockwise direction, the stem (6) can be unscrewed from the bonnet bush. When the stem (6) is disconnected from the bonnet bush, unscrew the gland nut and remove both this and the gland washer. Keep these parts safe as they are not supplied as spares. The stem/bellows assembly (6, 5) can now be withdrawn out of the bonnet (2). The second bellows collar gasket (9) can now be replaced - ensuring both the bellows support collar surface and bonnet surface are clean and the gasket is accurately located. Before the stem/bellows assembly (6, 5) is reassembled into the bonnet (2), the stem packing ring (15) should be replaced (see Section 6.4).

6.4 How to fit the stem packing

By following through Section 6.3 it is now possible to replace the stem packing ring (15). Two of these rings are provided in the spares kit but only one is required. Ensure all of the old stem packing material is removed from the bonnet cavity and all locating surfaces are clean. Valve assembly is the opposite to removal - remembering to fit a bellows collar gasket between the collar and the valve bonnet. Ensure the solid stem pin (which is pressed into the stem) is aligned with the slot inside the bonnet. Before screwing the end of the stem into the bonnet bush remember to fit a new stem packing ring (15), the original gland washer and gland nut over the stem. **Do not allow the stem thread to damage the inner surface of the gland packing ring.** Carefully slide the new packing ring down the stem into the cavity and slide the original gland washer on top of the packing ring. Remember to tighten the gland packing ring after the valve has been fully assembled.

6.5 How to fit the stem and bellows assembly

By following through Section 6.3 it is now possible to fit a new stem/bellows assembly (6, 5). Fitting this is opposite to removal - remembering to fit a bellows collar gasket (9) between the bellows support collar and valve bonnet (2). Ensure the bellows collar gasket (9) is accurately located. Before fitting the new stem/bellows assembly (6, 5) into the bonnet (2), apply a small amount of lubricating compound such as Gulf Sovereign LC grease to the end of the stem pin (which is pressed into the stem). Ensure the stem pin is aligned with the slot inside the bonnet. Carefully slide the stem up through the bonnet. Before screwing the end of the stem into the bonnet bush remember to fit a new stem packing ring (15) (see Section 6.4), the original gland washer and gland nut over the stem (6). **Do not allow the stem thread to damage the inner surface of the gland packing ring.** Carefully slide the new packing ring down the stem into the cavity and slide the original gland washer on top of the packing ring (15). Remember to tighten the gland packing ring after the valve has been fully assembled.

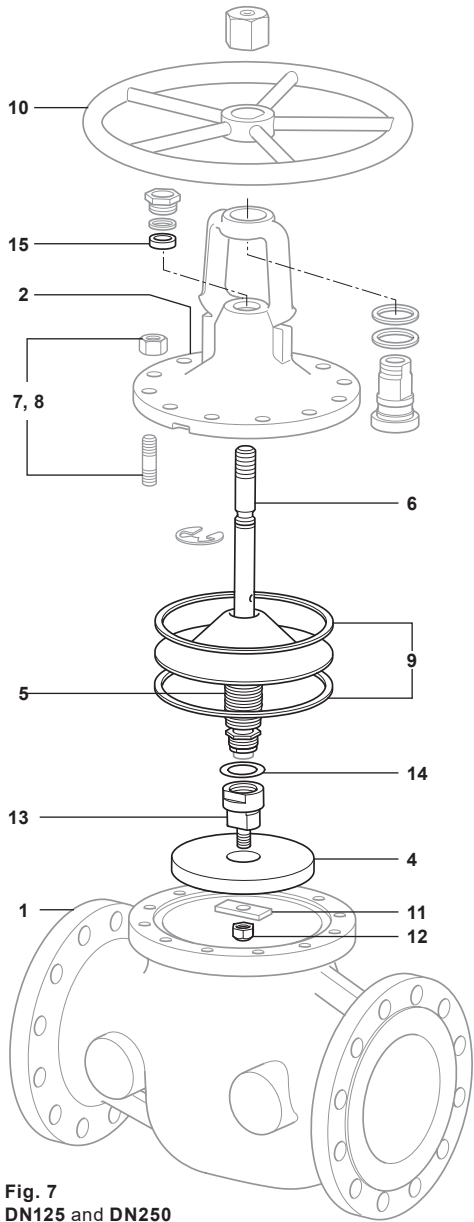

Fig. 7
DN125 and DN250

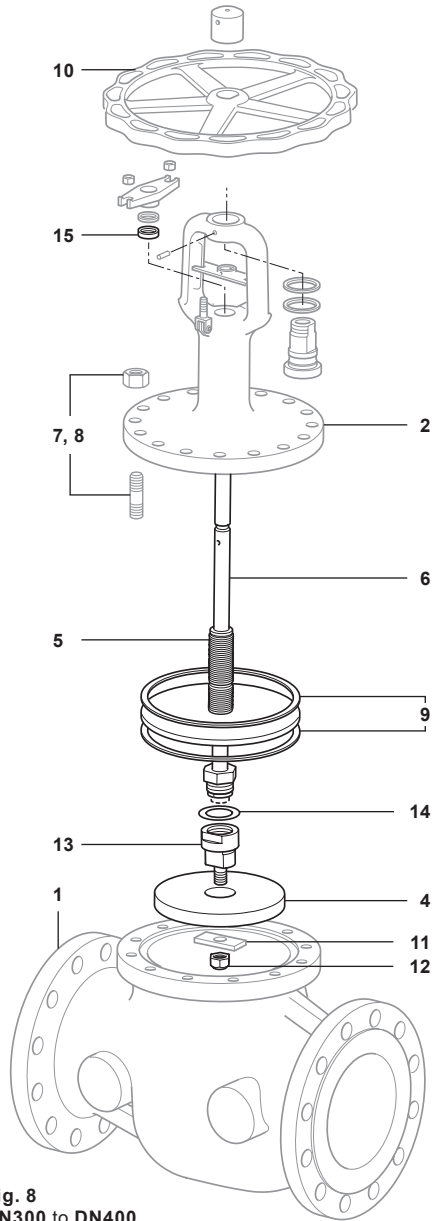

Fig. 8
DN300 to DN400

BSA3-BD and BSA6-BD Bellows Sealed Stop Valves

6.6 How to fit the disc

By following through Section 6.3 it is now possible to replace the valve's disc. To replace the disc (4) simply remove the old stem pin and replace the disc (4). Attach the new disc with the new stem pin (supplied). Where the disc (4) is attached using a retaining nut and collet arrangement, simply prise the crimped skirt away from the retaining nut and unscrew. Remove the collets remembering to save these and the retaining nut as they are not supplied as spares. Fitting is the opposite to removal but ensure the collets and threads are lightly greased with lubricating compound such as Molybdenum Sulphide.

If a new disc is being fitted then crimp the collet retaining nut securely across two corners by deforming the disc's thin metal skirt. If the original disc is being fitted then re-crimp using a fresh part of the skirt.

6.7 Final assembly

Ensure the bellows support collar and gaskets (9) are accurately aligned with the bonnet (2) before final assembly into the body (1).

Tighten the bonnet studs/nuts (7, 8) evenly to the recommended tightening torque (See Table 1).

Table 1 Recommended tightening torques

Item 7 and 8 Bonnet bolts and nuts	BSA3-BD	DN200	250 - 260 Nm
		DN250 and DN300	330 - 340 Nm
		DN350 and DN400	490 - 500 Nm
	BSA6-BD	DN125	250 - 260 Nm
		DN150	330 - 340 Nm
		DN200	490 - 500 Nm

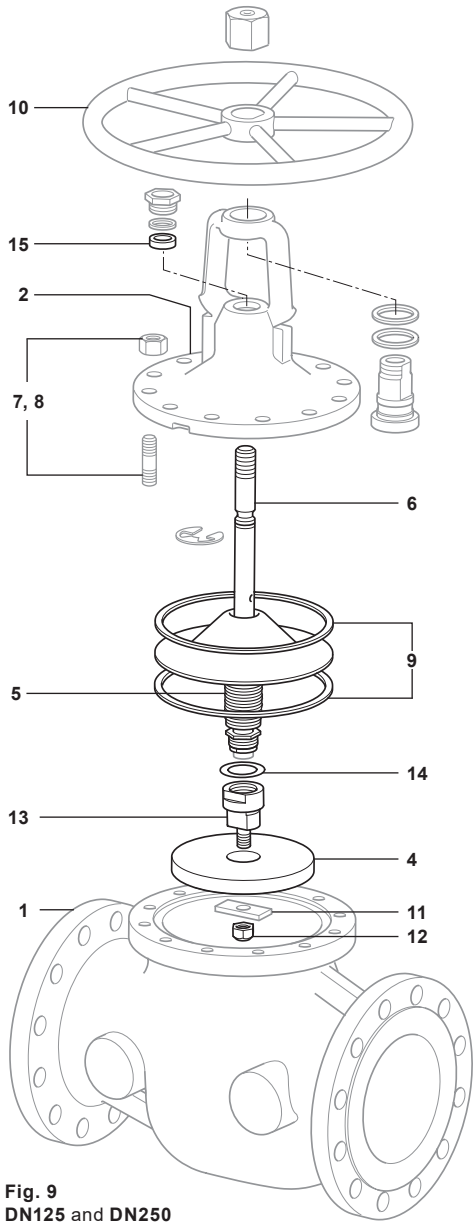

Fig. 9
DN125 and DN250

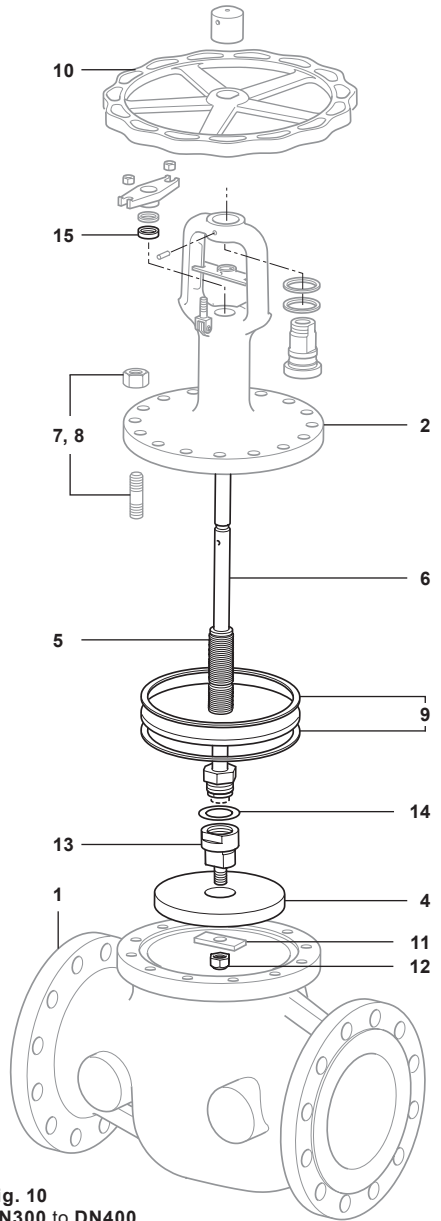

Fig. 10
DN300 to DN400

BSA3-BD and BSA6-BD Bellows Sealed Stop Valves

