

**BRV2 Range of
Pressure Reducing Valves**
Installation and Maintenance Instructions

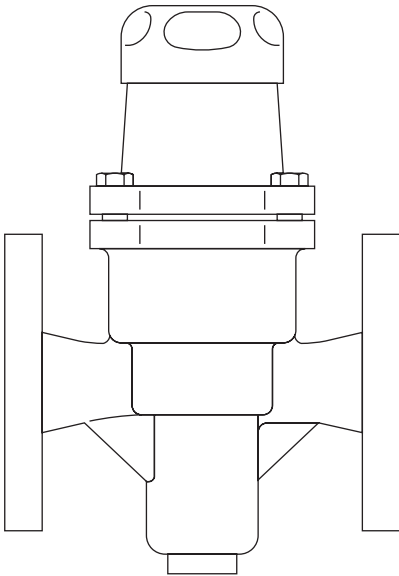

1. Safety information
2. General product information
3. Installation
4. Maintenance
5. Spare parts
6. Fault finding

1. Safety information

Safe operation of this product can only be guaranteed if it is properly installed, commissioned, used and maintained by qualified personnel (see Section 1.11) in compliance with the operating instructions. General installation and safety instructions for pipeline and plant construction, as well as the proper use of tools and safety equipment must also be complied with.

Warning

The bellows assembly gasket contains a thin stainless steel support ring which may cause physical injury if not handled and disposed of carefully.

1.1 Intended use

Referring to the Installation and Maintenance Instructions, name-plate and Technical Information Sheet, check that the product is suitable for the intended use/application. The product complies with the requirements of the European Pressure Equipment Directive 2014/68/EU and falls within category 'SEP'.

It should be noted that products within this category are required by the Directive not to carry the  mark.

- i) The product has been specifically designed for use on steam, compressed air and inert industrial gases which are in Group 2 of the above mentioned Pressure Equipment Directive. The products' use on other fluids may be possible but, if this is contemplated, Spirax Sarco should be contacted to confirm the suitability of the product for the application being considered.
- ii) Check material suitability, pressure and temperature and their maximum and minimum values. If the maximum operating limits of the product are lower than those of the system in which it is being fitted, or if malfunction of the product could result in a dangerous overpressure or overtemperature occurrence, ensure a safety device is included in the system to prevent such over-limit situations.
- iii) Determine the correct installation situation and direction of fluid flow.
- iv) Spirax Sarco products are not intended to withstand external stresses that may be induced by any system to which they are fitted. It is the responsibility of the installer to consider these stresses and take adequate precautions to minimise them.
- v) Remove protection covers from all connections and protective film from all name-plates, where appropriate, before installation on steam or other high temperature applications.

1.2 Access

Ensure safe access and if necessary a safe working platform (suitably guarded) before attempting to work on the product. Arrange suitable lifting gear if required.

1.3 Lighting

Ensure adequate lighting, particularly where detailed or intricate work is required.

1.4 Hazardous liquids or gases in the pipeline

Consider what is in the pipeline or what may have been in the pipeline at some previous time. Consider: flammable materials, substances hazardous to health, extremes of temperature.

1.5 Hazardous environment around the product

Consider: explosion risk areas, lack of oxygen (e.g. tanks, pits), dangerous gases, extremes of temperature, hot surfaces, fire hazard (e.g. during welding), excessive noise, moving machinery.

1.6 The system

Consider the effect on the complete system of the work proposed. Will any proposed action (e.g. closing isolation valves, electrical isolation) put any other part of the system or any personnel at risk?

Dangers might include isolation of vents or protective devices or the rendering ineffective of controls or alarms. Ensure isolation valves are turned on and off in a gradual way to avoid system shocks.

1.7 Pressure systems

Ensure that any pressure is isolated and safely vented to atmospheric pressure. Consider double isolation (double block and bleed) and the locking or labelling of closed valves. Do not assume that the system has depressurised even when the pressure gauge indicates zero.

1.8 Temperature

Allow time for temperature to normalise after isolation to avoid danger of burns.

1.9 Tools and consumables

Before starting work ensure that you have suitable tools and/or consumables available. Use only genuine Spirax Sarco replacement parts.

1.10 Protective clothing

Consider whether you and/or others in the vicinity require any protective clothing to protect against the hazards of, for example, chemicals, high/low temperature, radiation, noise, falling objects, and dangers to eyes and face.

1.11 Permits to work

All work must be carried out or be supervised by a suitably competent person.

Installation and operating personnel should be trained in the correct use of the product according to the Installation and Maintenance Instructions.

Where a formal 'permit to work' system is in force it must be complied with. Where there is no such system, it is recommended that a responsible person should know what work is going on and, where necessary, arrange to have an assistant whose primary responsibility is safety.

Post 'warning notices' if necessary.

1.12 Handling

Manual handling of large and/or heavy products may present a risk of injury. Lifting, pushing, pulling, carrying or supporting a load by bodily force can cause injury particularly to the back. You are advised to assess the risks taking into account the task, the individual, the load and the working environment and use the appropriate handling method depending on the circumstances of the work being done.

1.13 Residual hazards

In normal use the external surface of the product may be very hot. If used at the maximum permitted operating conditions the surface temperature of some products may reach temperatures of 210 °C (410 °F).

Many products are not self-draining. Take due care when dismantling or removing the product from an installation (refer to 'Maintenance instructions').

1.14 Freezing

Provision must be made to protect products which are not self-draining against frost damage in environments where they may be exposed to temperatures below freezing point.

1.15 Disposal

Unless otherwise stated in the Installation and Maintenance Instructions, this product is recyclable and no ecological hazard is anticipated with its disposal providing due care is taken.

Please visit the Spirax Sarco product compliance web pages

<https://www.spiraxsarco.com/product-compliance>

for up to date information on any substances of concern that may be contained within this product. Where no additional information is provided on the Spirax Sarco product compliance web page, this product may be safely recycled and/or disposed providing due care is taken. Always check your local recycling and disposal regulations.

1.16 Returning products

Customers and stockists are reminded that under EC Health, Safety and Environment Law, when returning products to Spirax Sarco they must provide information on any hazards and the precautions to be taken due to contamination residues or mechanical damage which may present a health, safety or environmental risk. This information must be provided in writing including Health and Safety data sheets relating to any substances identified as hazardous or potentially hazardous.

2. General product information

2.1 Description

The BRV2 range of direct acting pressure reducing valves are designed for applications using steam or gases such as compressed air.

Available types

Gunmetal body	BRV2S5	Stainless steel bellows
	BRV2B5	Phosphor bronze/brass bellows
SG iron body	BRV2S	Stainless steel bellows
	BRV2B	Phosphor bronze bellows
	BRV2SP	Stainless steel bellows
	BRV2BP	Phosphor bronze bellows

BRV2 pressure reducing valves are supplied with one of three colour coded springs which are identified by the disc (18) located on the adjustment handwheel (2).

Note: Where control spring ranges overlap always use the lower range to give better control:

Grey	For downstream pressure control:	0.14 to 1.7 bar g	(2.03 to 24.65 psi g)
Green	For downstream pressure control:	1.40 to 4.0 bar g	(20.30 to 58.00 psi g)
Orange	For downstream pressure control:	3.50 to 8.6 bar g	(50.75 to 124.70 psi g)

Standards

This product fully complies with the requirements of the European Pressure Equipment Directive 2014/68/EU.

Certification

This product is available with a manufacturers' Typical Test Report.

Note: All certification/inspection requirements must be stated at the time of order placement.

Note: For further product data see Technical Information Sheet, TI-P045-14.

2.2 Sizes and pipe connections

½", ¾" and 1" screwed BSP T Rp (ISO 7-1) or NPT.

DN15, DN20 and DN25 Flanged EN 1092 PN25.

Please note that the BRV2S5 and BRV2B5 are not available with flanged connections.

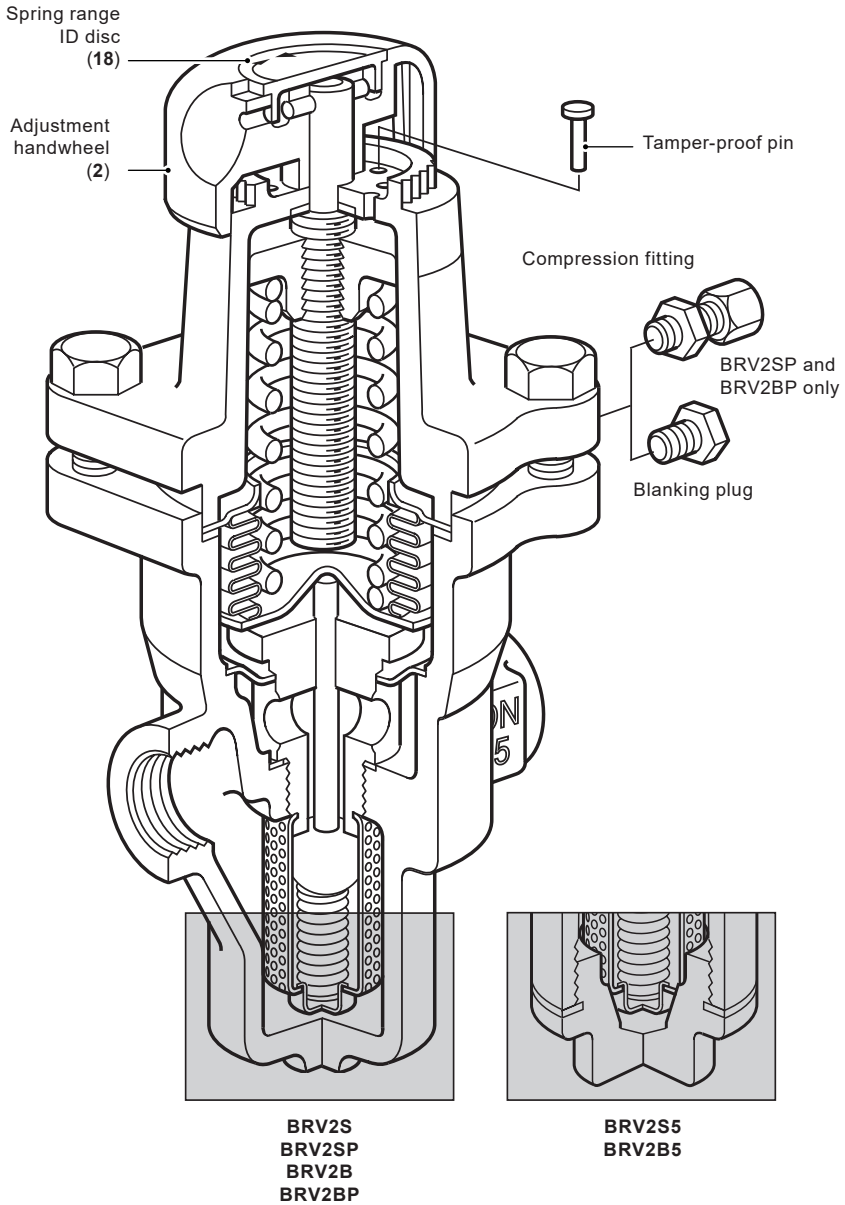
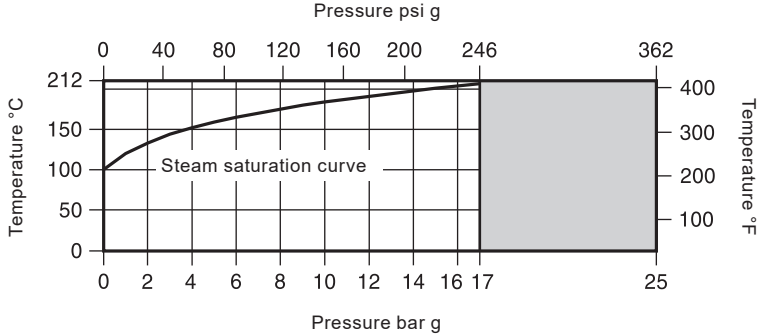

Fig. 1 BRV2 screwed body

BRV2 Range of Pressure Reducing Valves

2.3 Pressure/temperature limits

**BRV2B5
BRV2S5**



The product **must not** be used in this region.

Body design conditions	PN25	
Maximum design pressure	25 bar g @ 120 °C	(362 psi g @ 248 °F)
Maximum design temperature	210 °C @ 17 bar g	(410 °F @ 246 psi g)
Minimum design temperature	0 °C	(32 °F)
Maximum operating pressure for saturated steam service	17 bar g	(246 psi g)
Maximum operating temperature	210 °C @ 17 bar g	(410 °F @ 246 psi g)
Minimum operating temperature	0 °C	(32 °F)
Note: For lower operating temperatures consult Spirax Sarco		
Maximum downstream reduced pressure	8.6 bar g	(125 psi g)
Maximum differential pressure	17 bar	(246 psi)
Maximum recommended turndown ratio 10:1 at maximum flow		
Designed for a maximum cold hydraulic test pressure of:	38 bar g	(551 psi g)
Note: With internals fitted, test pressure must not exceed:	17 bar g	(246 psi g)

**BRV2B
BRV2S
BRV2BP
BRV2SP**

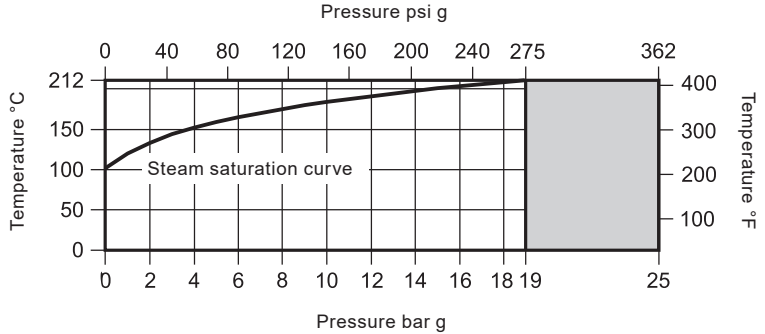

The product **must not** be used in this region.

Body design conditions	PN25	
Maximum design pressure	25 bar g @ 120 °C	(362 psi g @ 248 °F)
Maximum design temperature	210 °C @ 19 bar g	(410 °F @ 275 psi g)
Minimum design temperature	-10 °C	(14 °F)
Maximum operating pressure for saturated steam service	17 bar g	(246 psi g)
Maximum operating temperature	207 °C @ 17 bar g	(405 °F @ 246 psi g)
Minimum operating temperature	0 °C	(32 °F)
Note: For lower operating temperatures consult Spirax Sarco		
Maximum downstream reduced pressure	8.6 bar g	(125 psi g)
Maximum differential pressure	17 bar g	(246 psi g)
Maximum recommended turndown ratio 10:1 at maximum flow		
Designed for a maximum cold hydraulic test pressure of:	38 bar g	(551 psi g)
Note: With internals fitted, test pressure must not exceed:	19 bar g	(275 psi g)

BRV2 Range of Pressure Reducing Valves

3. Installation

Note: Before actioning any installation observe the 'Safety information' in Section 1.

Note: If you experience difficulty with installation or operation of this equipment please contact:

Spirax-Sarco Limited,
Charlton House,
Cheltenham,
Gloucestershire,
GL53 8ER,
UK
T +44 (0)1242 521361
F +44 (0)1242 573342
E enquiries@uk.spiraxsarco.com

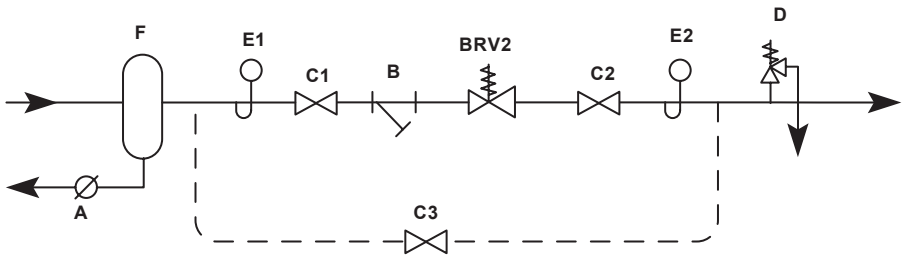

- A Steam trap
- B Strainer
- C Isolating valve
- D Safety valve
- E Pressure gauge
- F Separator

Fig. 2 Recommended installation

3.1 General installation

Always install the BRV2 with the flow direction arrow (on the body) pointing downstream.

The BRV2 pressure reducing valve is available either screwed ½", ¾" and 1" BSP T Rp (ISO 7-1) or flanged DN15, DN20 and DN25 EN 1092 PN25.

For installation recommendations for the BRV2SP or BRV2BP, using the external pressure sensing connection, see Section 3.4 and 3.5, pages 12 and 13.

The Spirax Sarco BRV2 pressure reducing valves should always be fitted in a horizontal pipeline. The adjustment head may be above or below the valve.

Isolating valves should be installed, upstream and downstream of the BRV2, with a clear run of 8 to 10 pipe diameters on either side.

It is important that line stresses, caused by expansion or inadequate pipe support, are not imposed on the valve body.

Upstream and downstream piping must be of ample size to avoid undue pressure drop. Any reduction in line size should be made using eccentric reducers.

Fitting a strainer on the upstream side will give additional protection to the valve. Install the strainer on its side to prevent the body filling with water, which will reduce the effective screening area. If the steam supply is wet a separator/trap set should be installed upstream. Alternatively, an adequate drain pocket and a trap from the Spirax Sarco range should be fitted.

A pressure gauge is essential on the downstream pipework to allow setting of the operating pressure. It is an advantage to have a gauge on the upstream side of the valve, as well.

Information regarding bypasses:

It may be necessary to ensure that primary fluid flow continues in the event of the main control failing. This is often achieved by fitting a bypass around the control valve assembly. A better option is a duplex valve assembly, installed in parallel with the main valve, as a manual bypass cannot accurately control pressure/flow/temperature without constant manual supervision. Conversely, a duplex control station will provide proper control, should the main valve ever need to be removed.

Although not recommended, if a manual bypass valve is fitted, the bypass valve flow coefficient (K_{VS}) should be the same as, or near to that of, the control valve. This means that the manual valve and control valve could have different connection sizes. The bypass valve should also be capable of throttling not just isolating, to reduce wear on the valve when in service and to facilitate manual control.

Ideally, any bypass pipework should be arranged either above or alongside the main assembly. On steam systems, it should never be below it.

Safety valve

A safety valve should be fitted to protect the downstream equipment from excessive pressure (to meet local standards). It should be set to lift below the safe working pressure of the downstream equipment, and will normally be sized to pass the full capacity of the BRV2 should it fail in the fully open position. The safety valve set pressure should take account of its reseal characteristic and the 'No-load' pressure setting of the BRV2. Discharge pipework should be taken to a safe place.

3.2 Start-up and adjustment for the BRV2

(See Section 3.5 for the Start-up and adjustment of the BRV2SP and BRV2P)

Before final installation, all pipework should be thoroughly 'blown through' to remove dirt, surplus jointing material, etc.

Pressure adjustment is made by turning the adjustment handwheel clockwise to increase pressure and anticlockwise to reduce pressure.

With the upstream stop valve fully open and the downstream stop valve closed, slowly increase the downstream pressure by turning the adjustment handwheel clockwise until the desired pressure (shown on the downstream pressure gauge) is achieved.

Slowly open the downstream stop valve.

Under normal flow condition, the reduced pressure setting will fall slightly, but will control under 'dead end' conditions. If required the pressure setting can be increased by readjusting the BRV2 control. There will be a slight increase in set pressure under 'No-load' conditions.

3.3 How to make the BRV2 tamper-proof:

- When the required set pressure has been achieved, lift out the coloured spring range ID disc (grey, green or orange) from the adjustment handwheel recess.

This is carried out by inserting a small screwdriver blade under the edge of the ID disc.

- A small loose pin will be found in the recess in the adjustment handwheel.
- This tamper-proof pin is inserted into the locking hole 'A', and into one of a ring of 10 matching holes in the top of the spring housing. The BRV2 is now tamper-proof.
- Replace the coloured spring range ID disc firmly into the recess of the adjustment handwheel.

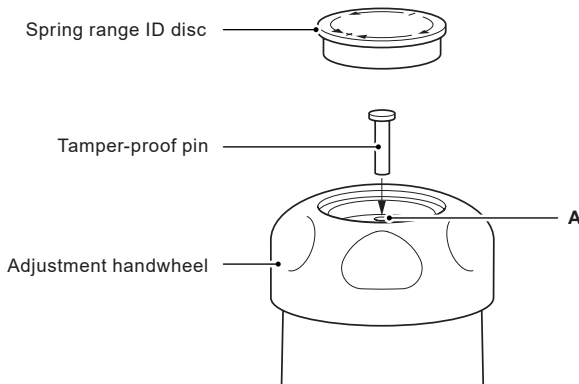

Fig. 3

3.4 Supplementary installation and start-up instructions for types BRV2SP and BRV2BP with external pressure sensing connection

To fit this downstream pressure sensing control remove the blanking plug '16', and install the $\frac{1}{8}$ "x 6 mm O/D compression fitting (17 - supplied).

The pressure sensing control pipe (6 mm O/D) should be connected into the top of the downstream pipework at point 'X' (see Figure 5), such that there is at least 1 m (3 ft) of straight pipe, free of fittings, between the BRV2P and point 'X'.

The pressure sensing control pipe should slope towards 'X'.

Alternatively, $\frac{1}{8}$ " nominal bore tube can be screwed into the main sensing connection. An isolating valve (C4) should be fitted.

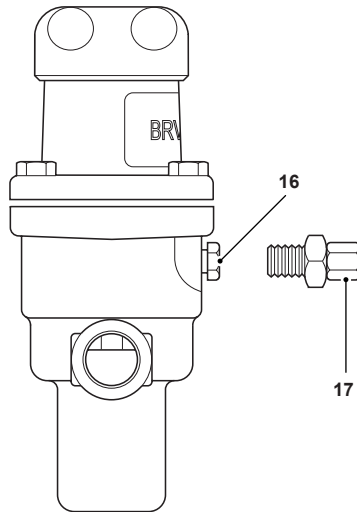
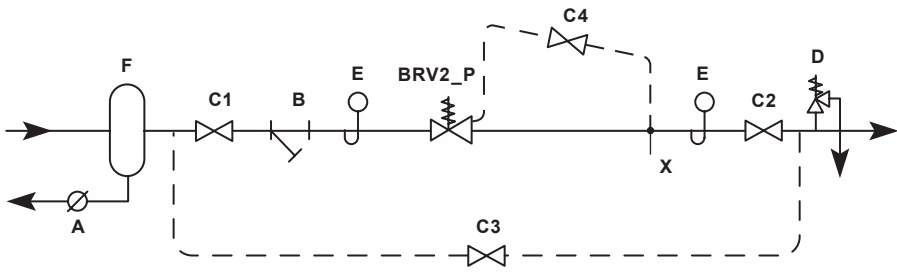

Fig. 4

Note: If you experience difficulty with installation or operation of this equipment please contact:

Spirax-Sarco Limited,
 Charlton House,
 Cheltenham,
 Gloucestershire,
 GL53 8ER,
 UK
 T +44 (0)1242 521361
 F +44 (0)1242 573342
 E enquiries@uk.spiraxsarco.com



- A Steam trap
- B Strainer
- C Isolating valve
- D Safety valve
- E Pressure gauge
- F Separator

Fig. 5 Recommended installation for the BRV2SP and the BRV2BP

3.5 Start-up and adjustment for the BRV2SP and BRV2BP

Close the isolating valves C2, and C3 if fitted, and open the isolating valve C4.

Slowly increase the downstream pressure by turning the BRV2_P adjustment handwheel clockwise until the required pressure (shown on the downstream pressure gauge) is reached.

Slowly open the isolating valve C2. Under flow conditions, the reduced pressure setting will fall slightly.

The pressure can be reset by readjusting the main control knob. In this case, there will be a small increase in set pressure under 'No-load' conditions.

Important note: The bypass line and the isolating valve C3 should be fitted when the installation is required to meet local requirements.

4. Maintenance

Note: Before actioning any maintenance programme observe the 'Safety information' in Section 1.

Warning

The bellows assembly gasket contains a thin stainless steel support ring which may cause physical injury if not handled and disposed of carefully.

4.1 General information

The valve and valve seat must be kept clean.



Any strainer fitted upstream of the BRV2 and strainer screen fitted inside the BRV2 should be cleaned regularly so that the flow to the valve is not restricted.

The internal strainer is part of the valve seat assembly. This may be withdrawn by removing the adjustment housing and bellows assembly and unscrewing the valve assembly, using a 32 mm A/F spanner.

4.2 How to fit a new valve and seat or clean the strainer screen:

1. Release the adjustment spring pressure by turning the adjustment handwheel (2) fully anticlockwise.
2. Remove the spring housing by undoing the 4 spring housing bolts (7) using 13 mm A/F spanner.
3. Lift out the bellows assembly (5) and the gasket (6).
4. Using a 32 mm A/F spanner, unscrew the valve seat (11) and remove the valve, the return spring, the strainer screen, the push rod and the guide bush.
5. Clean the strainer screen or replace with a new valve and seat assembly.
Note: the valve and seat assembly incorporates the strainer screen.
6. Reassemble in the reverse order, using new gaskets, ensuring that the components and seating faces are clean.
7. Tighten the valve seat to the following torque 108 - 132 N m (80 - 97 lbf ft).
8. Tighten the spring housing bolts to the following torque 18 - 24 N m (13 - 18 lbf ft).

Table 1 Recommended tightening torques

Item	Part	or		N m	(lbf ft)
					
7	Hex. bolts	13 A/F	M8 x 25	18 - 24	(13 - 18)
11	Valve seat	32 A/F		108 - 132	(80 - 97)
16	Bottom cap	32 A/F		65 - 75	(48 - 55)

BRV2 Range of Pressure Reducing Valves

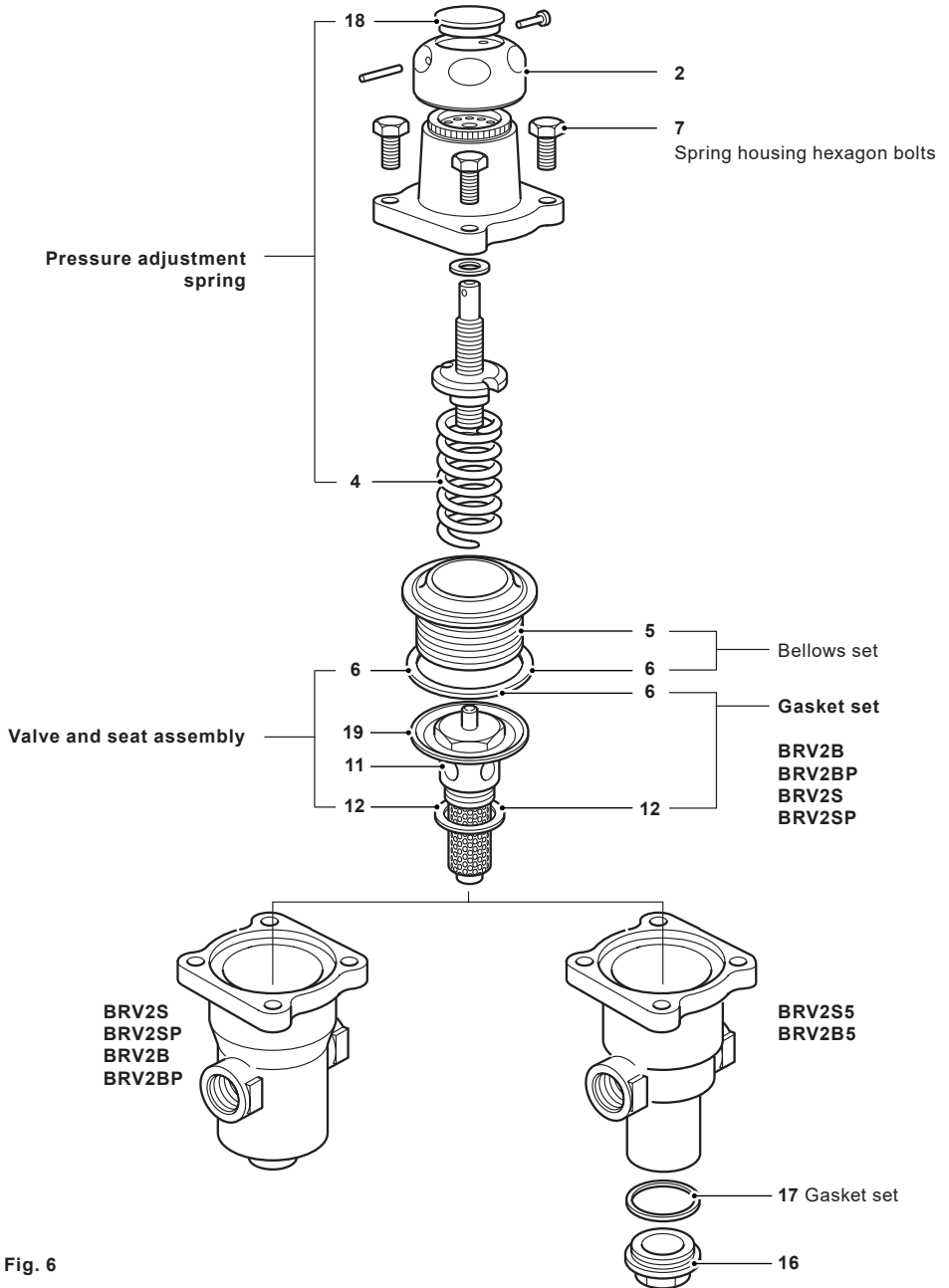

Fig. 6

BRV2 Range of Pressure Reducing Valves

4.3 How to fit the new bellows:

Follow Steps 1 to 3, Section 4.2, then proceed as follows:

1. Remove the cone shaped washer (9) from inside the bellows.
2. Replace the cone shaped washer, bellows gasket and assembly, adjustment spring and the spring housing, and tighten the spring housing bolts to the following torque 18 - 24 N m (13 - 18 lbf ft).

4.4 How to fit a replacement pressure adjustment spring:



Follow Steps 1 and 2, Section 4.2, then proceed as follows:

1. Replace the spring and bonnet assembly and tighten the spring housing bolts to the following torque 18 - 24 N m (13 - 18 lbf ft).
2. Lift out the spring identification disc (18) and press in a new disc (if spring range has been changed).

4.5 Cleaning the lower body section BRV2S5 and BRV2B5 only:

1. The lower body section can be cleaned internally by removing the bottom cap (16).
2. Replace the 'O' ring (17) and retighten the bottom cap (16) to the required torque.

Table 1 Recommended tightening torques

Item	Part		or 	N m	
				(lbf ft)	
7	Hex. bolts	13 A/F	M8 x 25	18 - 24	(13 - 18)
11	Valve seat	32 A/F		108 - 132	(80 - 97)
16	Bottom cap	32 A/F		65 - 75	(48 - 55)

5. Spare parts

The spare parts available are shown in solid outline. Parts drawn in a grey line are not supplied as spares.

Available spares

	Grey	0.14 to 1.7 bar g	4, 18
Pressure adjustment spring *	Green	1.40 to 4.0 bar g	4, 18
	Orange	3.50 to 8.6 bar g	4, 18
Bellows stainless steel (option of phosphor bronze if specified) *			5, 6
Spring housing bolts (set of 4) *			7
Valve and seat assembly			6, 11, 12, 19
Set of all gaskets/'O' ring *			6, 12, 17

Common to all sizes.

How to order spares

Always order spares by using the description given in the column headed 'Available spares' and state the size, type and pressure range of the reducing valve.

Example: 1 off Spirax Sarco pressure adjustment spring, having a downstream pressure range of 3.5 to 8.6 bar g (orange) for a DN15 type BRV2B pressure reducing valve.

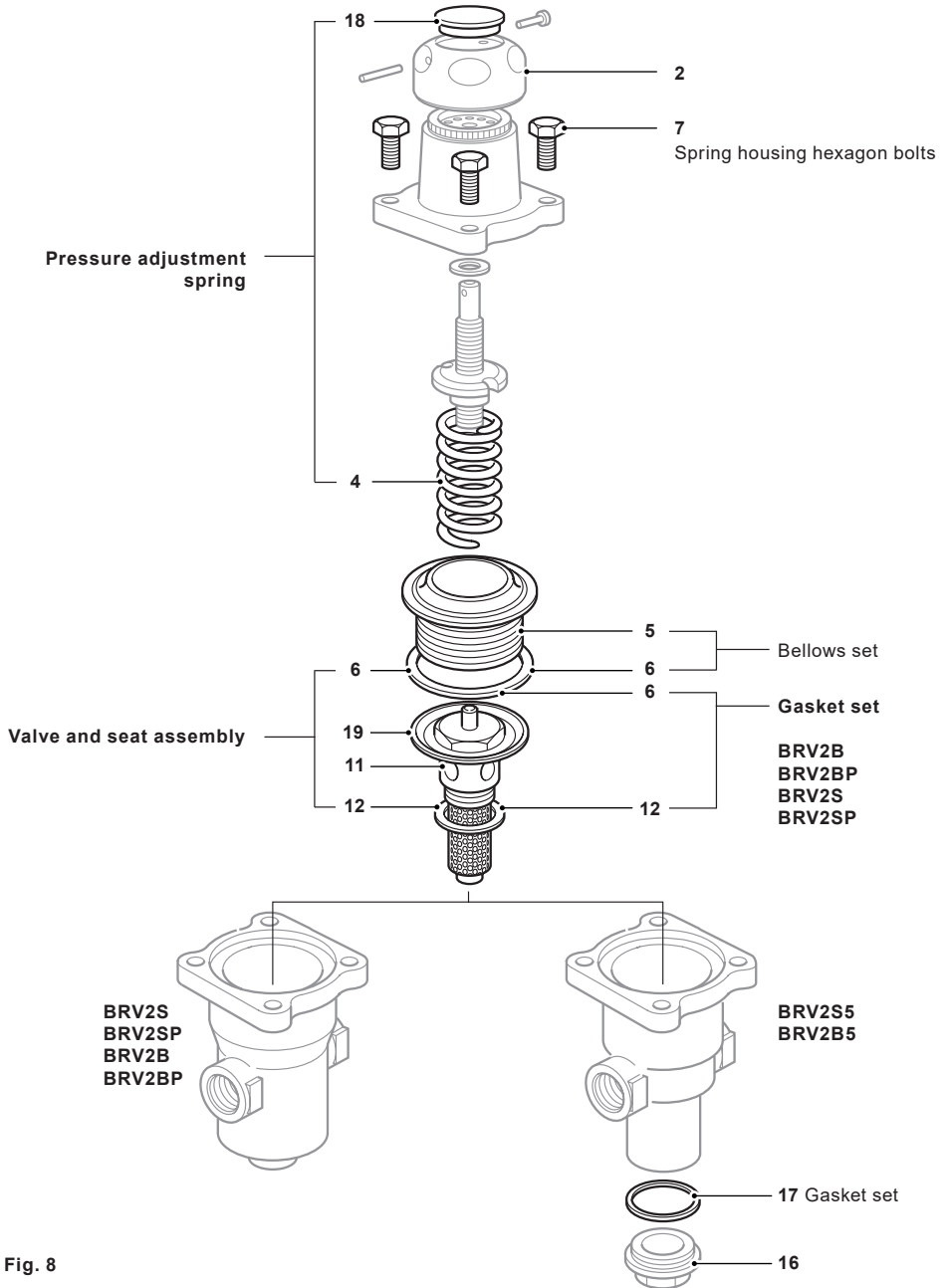

Fig. 8

BRV2 Range of Pressure Reducing Valves

6. Fault finding

Before investigating any fault ensure that both upstream and downstream isolating valves are shut off and that the BRV2 is vented.

SYMPTOM Downstream pressure increases above set pressure.

CAUSE 1 **Bellows failure or bellows leakage.**
CHECK and CURE Replace bellows set. Check valve is not subject to rapid oscillation causing bellows fatigue failure. Check bellows is not subject to corrosive attack e.g. for BRV2SP - chloride contamination. For BRV2BP - halide contamination.

CAUSE 2 **Damage or erosion to valve seat.**
CHECK and CURE Replace valve and seat assembly.

CAUSE 3 **Excessive dirt/scale build up on seat and head, blocked pressure sensing orifice/sticking push rod.**
CHECK and CURE Replace valve and seat assembly.

SYMPTOM Downstream pressure is below set pressure under full load conditions.

CAUSE 4 **Valve was set at 'No-load'.**
CHECK and CURE Reset at full load (Refer to start-up and adjustment, Section 3).

CAUSE 5 **Valve is undersized for required duty.**
CHECK and CURE Check maximum installed load and valve size selected and installed.

SYMPTOM Adjustment knob will not turn.

CAUSE 6 **Tamper-proof pin is preventing adjustment.**
CHECK and CURE Remove pin from cap.

SYMPTOM Hunting/unstable control.

CAUSE 7 **Wet steam.**
CHECK and CURE Ensure lines are properly trapped, install separator if necessary.

CAUSE 8 **Externally transmitted signals.**
CHECK and CURE Check proximity of valve to other associated control equipment e.g. on/off valves.

CAUSE 9 **Sticking pushrod due to dirt/scale build up.**
CHECK and CURE Replace valve and seat assembly.

