

BPT13

Balanced Pressure Thermostatic Steam Traps

Installation and Maintenance Instructions

**BPT13A and
BPT13AX**

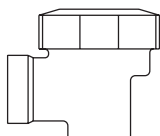

**BPT13S and
BPT13SX**

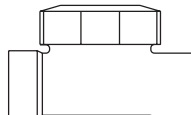

**BPT13UA and
BPT13UAX**

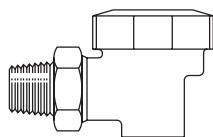

**BPT13US and
BPT13USX**

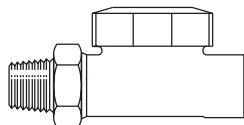

1. Safety information
2. General product information
3. Installation
4. Commissioning
5. Operation
6. Maintenance
7. Spare parts

1. Safety information

Safe operation of these products can only be guaranteed if they are properly installed, commissioned, used and maintained by qualified personnel (see Section 1.11) in compliance with the operating instructions. General installation and safety instructions for pipeline and plant construction, as well as the proper use of tools and safety equipment must also be complied with.

1.1 Intended use

Referring to the Installation and Maintenance Instructions, name-plate and Technical Information Sheet, check that the product is suitable for the intended use/application.

This product complies with the requirements of the European Pressure Equipment Directive 2014/68/EU and falls within category SEP and therefore does not carry the  mark.

Product	Group 2 Gases	Group 2 Liquids
BPT13A, BPT13AX, BPT13UA, BPT13UAX,		
BPT13S, BPT13SX, BPT13US, BPT13USX	SEP	SEP

- i) These products have been specifically designed for use on steam, air or water/condensate which are in Group 2 of the above mentioned Pressure Equipment Directive. The products' use on other fluids may be possible but, if this is contemplated, Spirax Sarco should be contacted to confirm the suitability of the product for the application being considered.
- ii) Check material suitability, pressure and temperature and their maximum and minimum values. If the maximum operating limits of the product are lower than those of the system in which it is being fitted, or if malfunction of the product could result in a dangerous overpressure or overtemperature occurrence, ensure a safety device is included in the system to prevent such over-limit situations.
- iii) Determine the correct installation situation and direction of fluid flow.
- iv) Spirax Sarco products are not intended to withstand external stresses that may be induced by any system to which they are fitted. It is the responsibility of the installer to consider these stresses and take adequate precautions to minimise them.
- v) Remove protection covers from all connections and protective film from all name-plates, where appropriate, before installation on steam or other high temperature applications.

1.2 Access

Ensure safe access and if necessary a safe working platform (suitably guarded) before attempting to work on the product. Arrange suitable lifting gear if required.

1.3 Lighting

Ensure adequate lighting, particularly where detailed or intricate work is required.

1.4 Hazardous liquids or gases in the pipeline

Consider what is in the pipeline or what may have been in the pipeline at some previous time. Consider: flammable materials, substances hazardous to health, extremes of temperature.

1.5 Hazardous environment around the product

Consider: explosion risk areas, lack of oxygen (e.g. tanks, pits), dangerous gases, extremes of temperature, hot surfaces, fire hazard (e.g. during welding), excessive noise, moving machinery.

1.6 The system

Consider the effect on the complete system of the work proposed. Will any proposed action (e.g. closing isolation valves, electrical isolation) put any other part of the system or any personnel at risk?

Dangers might include isolation of vents or protective devices or the rendering ineffective of controls or alarms. Ensure isolation valves are turned on and off in a gradual way to avoid system shocks.

1.7 Pressure systems

Ensure that any pressure is isolated and safely vented to atmospheric pressure. Consider double isolation (double block and bleed) and the locking or labelling of closed valves. Do not assume that the system has depressurised even when the pressure gauge indicates zero.

1.8 Temperature

Allow time for temperature to normalise after isolation to avoid danger of burns. If the 'O' ring has been subjected to a temperature approaching 315 °C (599 °F) or higher, it may have decomposed and formed hydrofluoric acid. Avoid skin contact and inhalation of any fumes as the acid will cause deep skin burns and damage the respiratory system.

1.9 Tools and consumables

Before starting work ensure that you have suitable tools and/or consumables available. Use only genuine Spirax Sarco replacement parts.

1.10 Protective clothing

Consider whether you and/or others in the vicinity require any protective clothing to protect against the hazards of, for example, chemicals, high/low temperature, radiation, noise, falling objects, and dangers to eyes and face.

1.11 Permits to work

All work must be carried out or be supervised by a suitably competent person. Installation and operating personnel should be trained in the correct use of the product according to the Installation and Maintenance Instructions.

Where a formal 'permit to work' system is in force it must be complied with. Where there is no such system, it is recommended that a responsible person should know what work is going on and, where necessary, arrange to have an assistant whose primary responsibility is safety. Post 'warning notices' if necessary.

1.12 Handling

Manual handling of large and/or heavy products may present a risk of injury. Lifting, pushing, pulling, carrying or supporting a load by bodily force can cause injury particularly to the back. You are advised to assess the risks taking into account the task, the individual, the load and the working environment and use the appropriate handling method depending on the circumstances of the work being done.

1.13 Residual hazards

In normal use the external surface of the product may be very hot. If used at the maximum permitted operating conditions the surface temperature of the products may reach temperatures in excess of 250 °C (482 °F).

The product is not self-draining. Take due care when dismantling or removing the product from an installation (refer to 'Maintenance instructions').

1.14 Freezing

Provision must be made to protect products which are not self-draining against frost damage in environments where they may be exposed to temperatures below freezing point.

1.15 Disposal

Apart from the 'O' ring this product is recyclable and no ecological hazard is anticipated with its disposal providing due care is taken.

If the recycling process involves a temperature approaching 315 °C caution is advised regarding decomposition of the fluorocarbon rubber 'O' ring (see also Section 1.8).

'O' ring:

- Can be landfilled, when in compliance with National and Local regulations.
- Can be incinerated, but a scrubber must be used to remove Hydrogen Fluoride, which is evolved from the product and with compliance to National and Local regulations.
- Is insoluble in aquatic media.

Please visit the Spirax Sarco product compliance web pages

<https://www.spiraxsarco.com/product-compliance>

for up to date information on any substances of concern that may be contained within this product. Where no additional information is provided on the Spirax Sarco product compliance web page, this product may be safely recycled and/or disposed providing due care is taken. Always check your local recycling and disposal regulations.

1.16 Returning products

Customers and stockists are reminded that under EC Health, Safety and Environment Law, when returning products to Spirax Sarco they must provide information on any hazards and the precautions to be taken due to contamination residues or mechanical damage which may present a health, safety or environmental risk. This information must be provided in writing including Health and Safety data sheets relating to any substances identified as hazardous or potentially hazardous.

2. General product information

2.1 Description

The BPT13 is a readily maintainable brass bodied, balanced pressure thermostatic steam trap.

Available types

BPT13A	Angled connections
BPT13AX	Angled connections with strainer screen
BPT13S	Straight connections
BPT13SX	Straight connections with strainer screen
BPT13UA	Angled connections, union inlet
BPT13UAX	Angled connections, union inlet with strainer screen
BPT13US	Straight connections, union inlet
BPT13USX	Straight connections, union inlet with strainer screen

Capsule fill and operation

When placing an order always state the capsule fill:

Standard capsule	Is marked with ' STD ' for operation at approximately 12 °C (53 °F) below steam saturation temperature.
Optionally	The capsule can be supplied for sub-cooled ' SUB ' operation at approximately 24 °C (75 °F) below steam saturation temperature. For critical applications the ' NTS ' fill capsule should be selected which operates at approximately 4 °C (7 °F) below steam saturation temperature.

Standards

This product fully complies with the requirements of the European Pressure Equipment Directive 2014/68/EU.

Certification

This product is available with a manufacturers' Typical Test Report.

Note: All certification/inspection requirements must be stated at the time of order placement.

Note: For further product data see the Technical Information Sheet TI-P122-01.

2.2 Sizes and pipe connections

$\frac{3}{8}$ " , $\frac{1}{2}$ " and $\frac{3}{4}$ " screwed BSP (BS 21 parallel) or NPT.

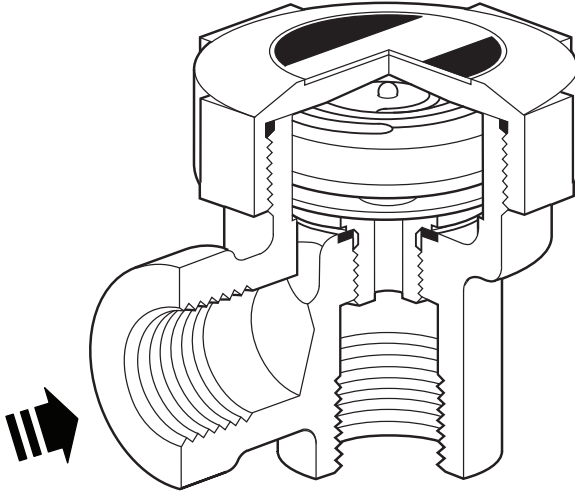
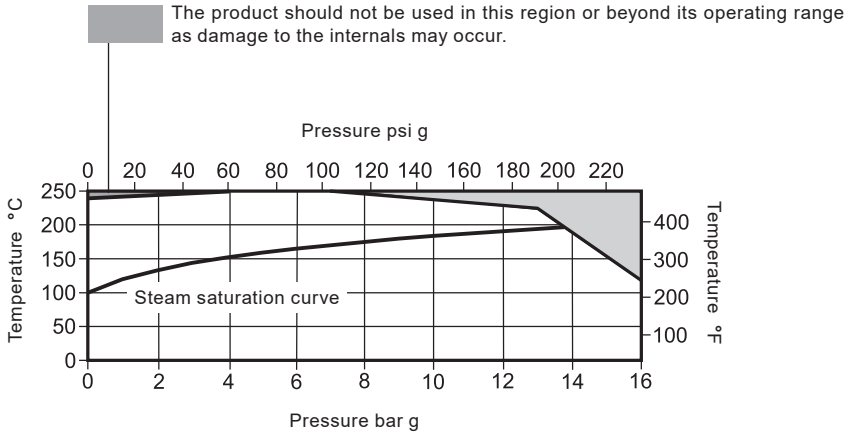

Fig. 1 BPT13A

2.3 Pressure/temperature limits (ISO 6552)



The product **must not** be used in this region.

Body design conditions		PN16
PMA	Maximum allowable pressure	16 bar g @ 120 °C (232 psi g @ 248 °F)
TMA	Maximum allowable temperature	250 °C @ 7 bar g (482 °F @ 102 psi g)
Minimum allowable temperature		-20 °C (-4 °F)
PMO	Maximum operating pressure	13 bar g @ 220 °C (189 psi g @ 428 psi g)
TMO	Maximum operating temperature	250 °C @ 7 bar g (482 °F @ 102 psi g)
Minimum operating temperature		0 °C (32 °F)
Designed for a maximum cold hydraulic test pressure of:		24 bar g (348 psi g)

3. Installation

Note: Before actioning any installation observe the 'Safety information' in Section 1.

Referring to the Installation and Maintenance Instructions, name-plate and Technical Information Sheet, check that the product is suitable for the intended installation:

- 3.1** Check materials, pressure and temperature and their maximum values. If the maximum operating limit of the product is lower than that of the system in which it is being fitted, ensure that a safety device is included in the system to prevent overpressurisation.
- 3.2** Determine the correct installation situation and the direction of fluid flow.
- 3.3** Remove protective covers from all connections and the protective film from all name-plates, where appropriate, before installation on steam or other high temperature applications.
- 3.4** The BPT13 is designed for installation with the capsule in a horizontal plane with the cap at the top. Ideally, as with all thermostatic steam traps, a drop/cooling leg should be employed to prevent any 'cooling' condensate from backing up into the steam main.
- 3.5** When the trap is discharging to atmosphere, it is strongly recommended to install a diffuser on the outlet side of the trap.
This reduces any problem of noise and erosion by cushioning high velocity discharge.
See TI-P155-02 for further information.
- 3.6** Isolation valves must be installed to allow for safe maintenance and trap replacement.
- 3.7** Open the isolation slowly until normal operating conditions are achieved.
- 3.8** Check for leaks and correct operation.
- 3.9** Ensure adequate space is left to remove the cover from the body for maintenance. Minimum withdrawal distance for the cover is 55 mm.

Note: If the trap is to discharge to atmosphere ensure it is to a safe place as the discharging fluid may be at a temperature of 100 °C (212 °F).

4. Commissioning

After installation or maintenance ensure that the system is fully functional. Carry out tests on any alarms or protective devices.

5. Operation

The operating element is a capsule containing a small quantity of a special liquid with a boiling point below that of water. In the cold conditions that exist at start-up, the capsule is relaxed. The valve is off its seat and is wide open, allowing unrestricted removal of air. This is a feature of all balanced pressure traps and explains why they are well suited to air venting.

As condensate passes through the balanced pressure steam trap, heat is transferred to the liquid in the capsule. The fill liquid boils before steam reaches the trap. The vapour pressure within the capsule causes it to expand and the trap shuts. Heat loss from the trap then cools the water surrounding the capsule, the fill condenses and the capsule contracts, opening the valve and releasing condensate until steam temperature approaches again at which the cycle is repeated.

6. Maintenance

Note: Before actioning any maintenance programme observe the 'Safety information' in Section 1.

6.1 General information



Before undertaking any maintenance on the trap it must be isolated from both the supply line and return line and any pressure allowed to safely normalise to atmosphere. The trap should then be allowed to cool. When reassembling, ensure that all joint faces are clean.

Maintenance can be completed with the trap in the pipeline, once the safety procedures have been observed. It is recommended that new gaskets and spares are used whenever maintenance is undertaken. Ensure that the correct tools and necessary protective equipment are used at all times. When maintenance is complete open isolation valves slowly and check for leaks.

6.2 How to fit a new capsule and seat:

- Remove the cap (2) using a spanner.
- Lift out the spring (5), capsule (4) and spacer plate (6).
- Unscrew the valve seat (7).
- Remove the strainer screen (9) if present and the seat gasket (8).
- Fit a new seat gasket (8) and clean the strainer screen (9) before replacing or replace the strainer screen with new.
- Screw in a new valve seat (7). Use a small amount of anti-seize compound on the threads and tighten to the recommended torque (see Table 1).
- Drop in the new spacer plate (6) ensuring it is located centrally on the valve seat (7). **Note:** Early spacer plates are unidirectional and must be fitted with the highest points uppermost. This does not apply to later models, which can be fitted either way up.
- Fit the new capsule (4) and spring (5) ensuring that the conical spring is positioned with the narrow end pointing downwards in contact with the capsule.
- Screw on the cap (2) using a new 'O' ring (3) assembled into the groove in the top of the cap, or in older models using a new gasket. **Note:** The spares pack contains 2 sizes of 'O' ring, use of the correct 'O' ring is explained in the note contained within the package. Tighten to the recommended torque (see Table 1).

Table 1 Recommended tightening torques

Item	Part		 or mm		N m	(lbf ft)
2	Cap	'O' ring	50 A/F		50 - 60	(37 - 44)
		Gasket	50 A/F	M10 x 30	90 - 110	(37 - 44)
7	Seat		17 A/F		35 - 40	(26 - 29)

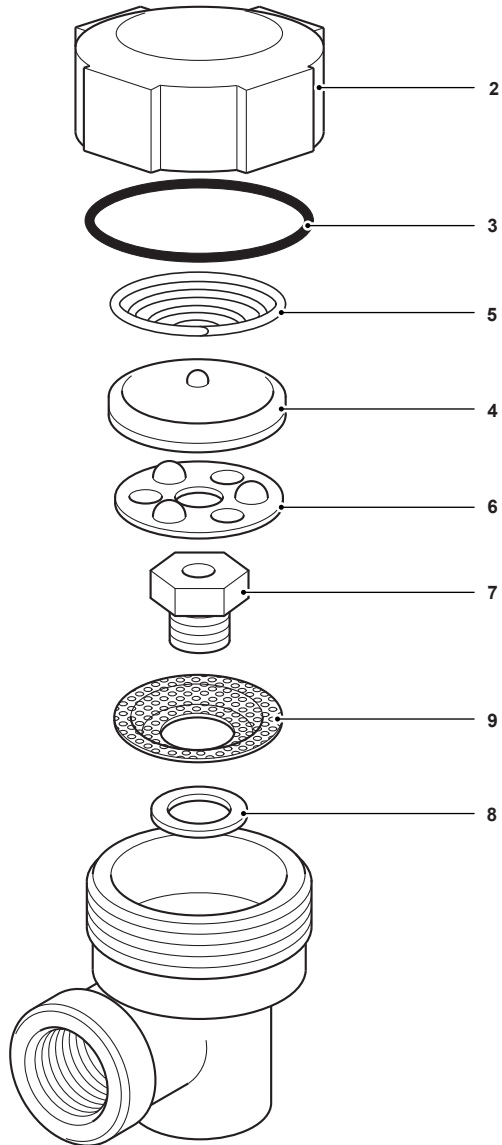

Fig. 2a BPT13AX

6.3 How to clean or replace the strainer screen: (BPT13AX / UAX / SX / USX)

- Remove the cap (2) using a spanner.
- Lift out the spring (5), capsule (4) and spacer plate (6).
- Unscrew the valve seat (7).
- Remove the strainer screen (9) and the seat gasket (8).
- Fit a new seat gasket (8) and clean the strainer screen (9) before replacing or replace the strainer screen with new.
- Screw in a new valve seat (7). Use a small amount of anti-seize compound on the threads and tighten to the recommended torque (see Table 1).
- Drop in the new spacer plate (6) ensuring it is located centrally on the valve seat (7). **Note:** Early spacer plates are unidirectional and must be fitted with the highest points uppermost. This does not apply to later models, which can be fitted either way up.
- Fit the new capsule (4) and spring (5) ensuring that the conical spring is positioned with the narrow end pointing downwards in contact with the capsule.
- Screw on the cap (2) using a new 'O' ring (3) assembled into the groove in the top of the cap, or in older models using a new gasket. **Note:** The spares pack contains 2 sizes of 'O' ring, use of the correct 'O' ring is explained in the note contained within the package. Tighten to the recommended torque (see Table 1).

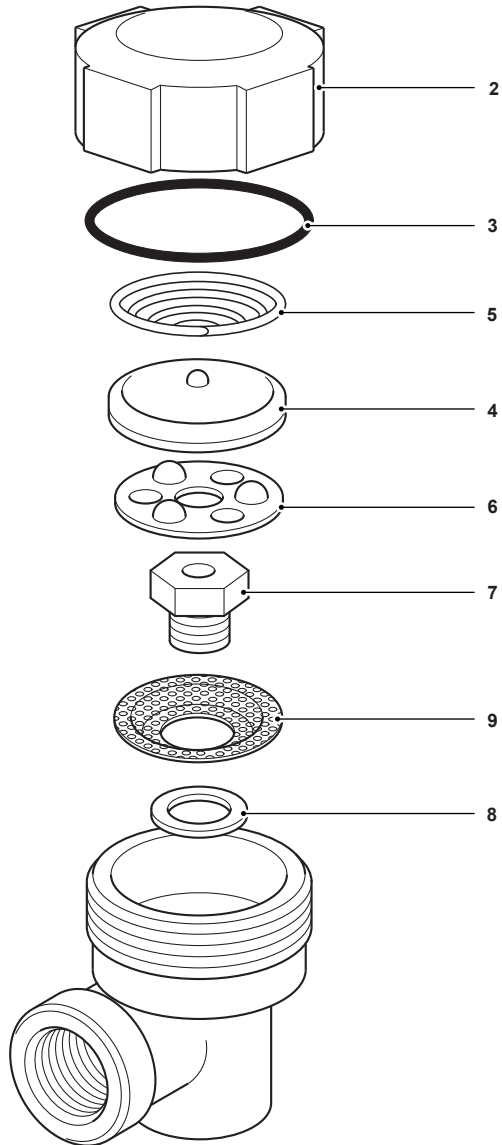

Fig. 2a BPT13AX

7. Spare parts

The spare parts available are shown in solid outline. Parts drawn in a grey line are not supplied as spares.

Available spares

Maintenance kit			3, 4, 5, 6, 7, 8, 9
Cap gasket	Earlier models	(packet of 3)	3
'O' ring	Current models	(2 x packet of 3)	3
Screen		(packet of 3)	3, 9

Note: Earlier models were fitted with conventional gaskets. Current models are fitted with an 'O' ring to seal the cap. There are two types of 'O' ring. The 'O' ring used is dependant on the body type.

How to order spares

Always order spares by using the description given in the column headed 'Available spares' and state the size, model number and capsule reference.

Example: 1 - Capsule and seat assembly for a Spirax Sarco ½" BPT13S balanced pressure thermostatic steam trap.

Note: If a non-standard fill capsule has been fitted then the name-plate on the cap is marked with the letters 'NTS' or 'SUB'. The near-to-steam (NTS) capsule can be used, for example, on hospital sterilisers and wet steaming ovens. Sub-cooled-capsules (SUB) can be used, for example, on vacuum return systems. For further details on capsule fill and operation see Section 2.1. Capsule type should be specified on the order otherwise a standard version will be supplied. Older models may be marked slightly differently. Possible markings are 'G', or 'F'. 'G' is equivalent to 'NTS' and 'F' is equivalent to 'SUB'.

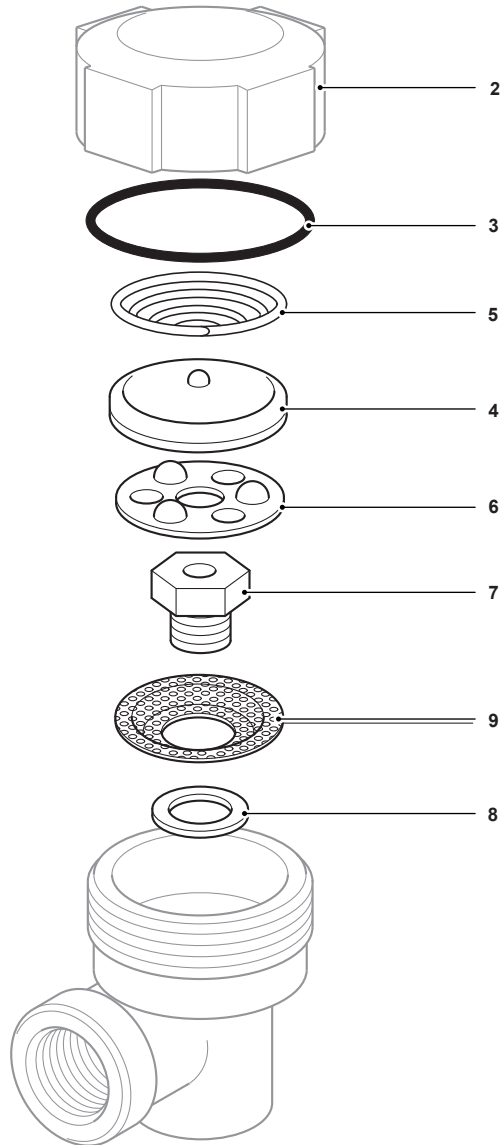

Fig. 3 BPT13AX

