

---

# BPM21L Carbon Steel Balanced Pressure Throstatic Steam Trap

## Installation and Maintenance Instructions

---

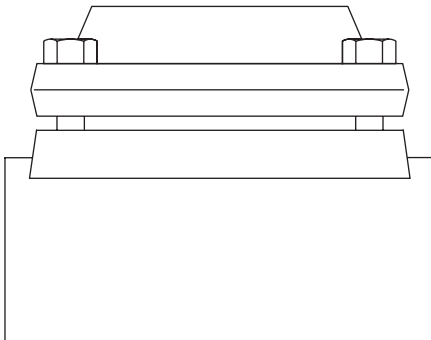

1. Safety information
2. General product information
3. Installation
4. Commissioning
5. Operation
6. Maintenance
7. Spare parts

---

**BPM21L Carbon Steel Balanced Pressure Thermostatic Steam Trap**

# 1. Safety information

Safe operation of this product can only be guaranteed if it is properly installed, commissioned, used and maintained by qualified personnel (see Section 1.11) in compliance with the operating instructions. General installation and safety instructions for pipeline and plant construction, as well as the proper use of tools and safety equipment must also be complied with.

## 1.1 Intended use

Referring to the Installation and Maintenance Instructions, name-plate and Technical Information Sheet, check that the product is suitable for the intended use/application.

This product complies with the requirements of the European Pressure Equipment Directive 2014/68/EU and falls within category SEP and therefore does not carry the  mark.

Product	Group 2 Gases	Group 2 Liquids
BPM21L	SEP	SEP

- i) The product has been specifically designed for use on steam, air or water /condensate which are in Group 2 of the above mentioned Pressure Equipment Directive. The products' use on other fluids may be possible but, if this is contemplated, Spirax Sarco should be contacted to confirm the suitability of the product for the application being considered.
- ii) Check material suitability, pressure and temperature and their maximum and minimum values. If the maximum operating limits of the product are lower than those of the system in which it is being fitted, or if malfunction of the product could result in a dangerous overpressure or overtemperature occurrence, ensure a safety device is included in the system to prevent such over-limit situations.
- iii) Determine the correct installation situation and direction of fluid flow.
- iv) Spirax Sarco products are not intended to withstand external stresses that may be induced by any system to which they are fitted. It is the responsibility of the installer to consider these stresses and take adequate precautions to minimise them.
- v) Remove protection covers from all connections before installation.

## 1.2 Access

Ensure safe access and if necessary a safe working platform (suitably guarded) before attempting to work on the product. Arrange suitable lifting gear if required.

## 1.3 Lighting

Ensure adequate lighting, particularly where detailed or intricate work is required.

## 1.4 Hazardous liquids or gases in the pipeline

Consider what is in the pipeline or what may have been in the pipeline at some previous time. Consider: flammable materials, substances hazardous to health, extremes of temperature.

## 1.5 Hazardous environment around the product

Consider: explosion risk areas, lack of oxygen (e.g. tanks, pits), dangerous gases, extremes of temperature, hot surfaces, fire hazard (e.g. during welding), excessive noise, moving machinery.

## 1.6 The system

Consider the effect on the complete system of the work proposed. Will any proposed action (e.g. closing isolation valves, electrical isolation) put any other part of the system or any personnel at risk?

Dangers might include isolation of vents or protective devices or the rendering ineffective of controls or alarms. Ensure isolation valves are turned on and off in a gradual way to avoid system shocks.

## 1.7 Pressure systems

Ensure that any pressure is isolated and safely vented to atmospheric pressure. Consider double isolation (double block and bleed) and the locking or labelling of closed valves. Do not assume that the system has depressurised even when the pressure gauge indicates zero.

## 1.8 Temperature

Allow time for temperature to normalise after isolation to avoid danger of burns.

## 1.9 Tools and consumables

Before starting work ensure that you have suitable tools and/or consumables available. Use only genuine Spirax Sarco replacement parts.

## 1.10 Protective clothing

Consider whether you and/or others in the vicinity require any protective clothing to protect against the hazards of, for example, chemicals, high/low temperature, radiation, noise, falling objects, and dangers to eyes and face.

## 1.11 Permits to work

All work must be carried out or be supervised by a suitably competent person. Installation and operating personnel should be trained in the correct use of the product according to the Installation and Maintenance Instructions.

Where a formal 'permit to work' system is in force it must be complied with. Where there is no such system, it is recommended that a responsible person should know what work is going on and, where necessary, arrange to have an assistant whose primary responsibility is safety.

Post 'warning notices' if necessary.

## 1.12 Handling

Manual handling of large and/or heavy products may present a risk of injury. Lifting, pushing, pulling, carrying or supporting a load by bodily force can cause injury particularly to the back. You are advised to assess the risks taking into account the task, the individual, the load and the working environment and use the appropriate handling method depending on the circumstances of the work being done.

### **1.13 Residual hazards**

In normal use the external surface of the product may be very hot. If used at the maximum permitted operating conditions the surface temperature of some products may reach temperatures in excess of 300 °C (572 °F).

Many products are not self-draining. Take due care when dismantling or removing the product from an installation (refer to 'Maintenance instructions').

### **1.14 Freezing**

Provision must be made to protect products which are not self-draining against frost damage in environments where they may be exposed to temperatures below freezing point.

### **1.15 Safety information - Product specific**

The cover gasket contains a thin stainless steel support ring which may cause physical injury if not handled and disposed of carefully.

### **1.16 Disposal**

Unless otherwise stated in the Installation and Maintenance Instructions, this product is recyclable and no ecological hazard is anticipated with its disposal providing due care is taken.

Please visit the Spirax Sarco product compliance web pages

<https://www.spiraxsarco.com/product-compliance>

for up to date information on any substances of concern that may be contained within this product.

Where no additional information is provided on the Spirax Sarco product compliance web page, this product may be safely recycled and/or disposed providing due care is taken. Always check your local recycling and disposal regulations.

### **1.17 Returning products**

Customers and stockists are reminded that under EC Health, Safety and Environment Law, when returning products to Spirax Sarco they must provide information on any hazards and the precautions to be taken due to contamination residues or mechanical damage which may present a health, safety or environmental risk. This information must be provided in writing including Health and Safety data sheets relating to any substances identified as hazardous or potentially hazardous.

## 2. General product information

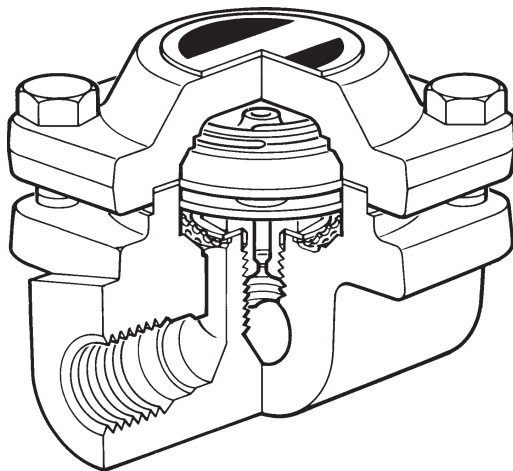

Fig. 1 BPM21L

### 2.1 Description

The BPM21L is a compact, carbon steel, balanced pressure steam trap, having an internal strainer. It is ideally suited for applications where space is important such as OEM machinery.

#### Options

**Capsule fill and operation** - As standard, the capsule fitted will operate at approximately 13 °C (55 °F) below steam saturation temperature (STD). Alternatively, a near-to-steam (NTS) capsule can be fitted that will operate at approximately 6 °C (43 °F) below steam saturation temperature or a sub-cooling (SUB) capsule can be fitted that will operate at approximately 24 °C (75 °F) below steam saturation temperature.

**Non-return/check valve** - All versions can be supplied with an integral check valve and are designated **BPM21LCV**.

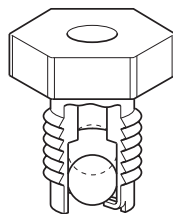

#### Standards

The product fully complies with the requirements of the European Pressure Equipment Directive 2014/68/EU.

#### Certification

The product is available with a manufacturers Typical Test Report.

**Note:** All certification/inspection requirements must be stated at the time of order placement.

**Note:** For all additional information see Technical Information Sheet, T1-P124-08.

## 2.2 Sizes and pipe connections

3/8" and 1/2" screwed BSP T Rp (ISO 7-1) or NPT.  
 Socket weld ends (1/2" **only**).

## 2.3 Pressure/temperature limits (ISO 6552)

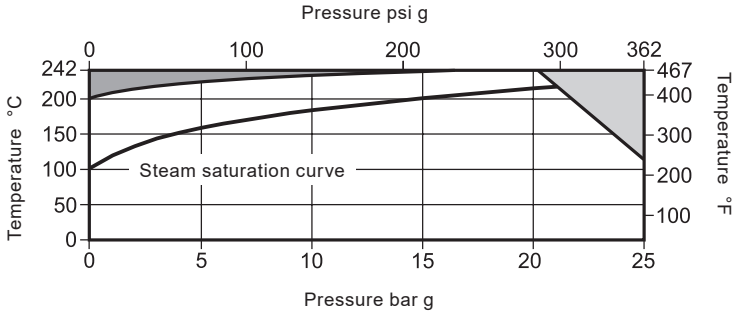

The product **must not** be used in this region.

The product should not be used in this region or beyond its operating range as damage to the internals may occur.

Body design conditions		PN25	
PMA	Maximum allowable pressure	25 bar g @ 120 °C	(362 psi g @ 248 °F)
TMA	Maximum allowable temperature	242 °C @ 20 bar g	(467 °F @ 290 psi g)
	Minimum allowable temperature	-10 °C	(14 °F)
PMO	Maximum operating pressure	21 bar g @ 217 °C	(304 psi g @ 422 °F)
TMO	Maximum operating temperature	242 °C @ 20 bar g	(467 °F @ 290 psi g)
	Minimum operating temperature	0 °C	(32 °F)
Designed for a maximum cold hydraulic test pressure of:		38 bar g	(551 psi g)

BPM21L Carbon Steel Balanced Pressure Thermostatic Steam Trap

# 3. Installation

**Note:** Before actioning any installation observe the 'Safety information' in Section 1.

Referring to the Installation and Maintenance Instructions, name-plate and Technical Information Sheet, check that the product is suitable for the intended installation:

- 3.1** Check materials, pressure and temperature and their maximum values. If the maximum operating limit of the product is lower than that of the system in which it is being fitted, ensure that a safety device is included in the system to prevent overpressurisation.
- 3.2** Determine the correct installation situation and the direction of fluid flow.
- 3.3** Remove protective covers from all connections and the protective film from all name-plates, where appropriate, before installation on steam or other high temperature applications.
- 3.4** The trap is designed for installation in any position, horizontal or vertical, preferably with a drop leg immediately preceding the trap - typically 150 mm (6") see Figure 2. **Caution:** If no drop leg is allowed then it may be possible (under low load conditions) for steam to flow over the condensate in the bottom of the pipe and reach the trap.
- 3.5** Unless the BPM21LCV is used, always fit a non-return (check) valve downstream of any steam traps which discharge into condensate return lines where backpressure is experienced. This is most commonly caused by a rising condensate line. The check valve will prevent the steam space flooding when the inlet pressure is reduced or the steam is shut off. Use a suitable valve such as the Spirax Sarco DCV41, see Figure 2.
- 3.6** When the trap is discharging to atmosphere, it is strongly recommended to install a diffuser on the outlet side of the trap. This reduces any problem of noise and erosion by cushioning high velocity discharge. See TI-P155-02 for further information.
- 3.7** Isolation valves must be installed to allow for safe maintenance and trap replacement.
- 3.8** Open isolation valves slowly until normal operating conditions are achieved.
- 3.9** Check for leaks and correct operation.
- 3.10** Ensure adequate space is left to remove the cover from the body for maintenance. Minimum withdrawal distance for the cover is 20 mm (¾").
- 3.11** **Welding into the pipeline** - There is no need to remove the operating capsule from the product providing the welding is performed using the electric arc method. For specific weld procedures consult the relevant National and International welding standards.

**Note:** If the trap is to discharge to atmosphere ensure it is to a safe place as the discharging fluid may be at a temperature of 100 °C (212 °F).



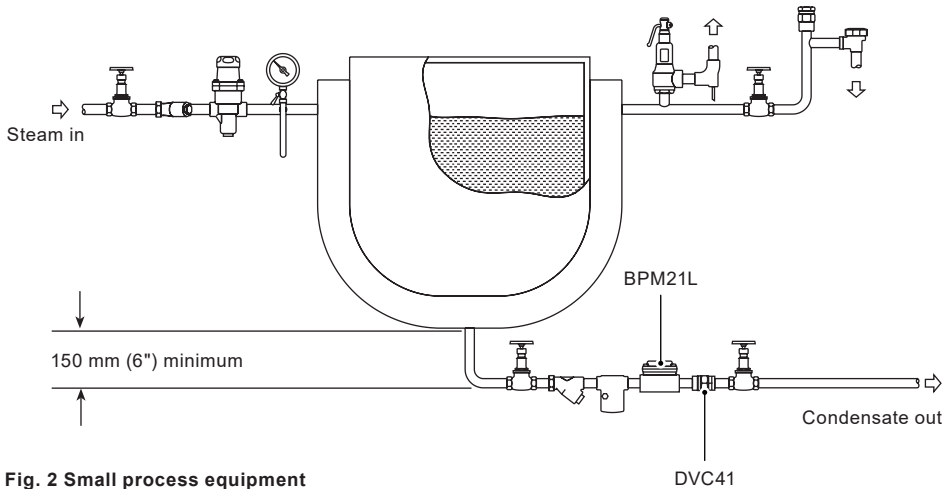

Fig. 2 Small process equipment

## 4. Commissioning

After installation or maintenance ensure that the system is fully functional. Carry out tests on any alarms or protective devices.

## 5. Operation

The operating element is a capsule containing a small quantity of a special liquid with a boiling point below that of water. In the cold conditions that exist at start-up, the capsule is relaxed. The valve is off its seat and is wide open, allowing unrestricted removal of air. This is a feature of all balanced pressure traps and explains why they are well suited to air venting.

As condensate passes through the balanced pressure steam trap, heat is transferred to the liquid in the capsule. The fill liquid boils before steam reaches the trap. The vapour pressure within the capsule causes it to expand and the trap shuts. Heat loss from the trap then cools the water surrounding the capsule, the fill condenses and the capsule contracts, opening the valve and releasing condensate until steam temperature approaches again at which the cycle is repeated.

---

BPM21L Carbon Steel Balanced Pressure Thermostatic Steam Trap

# 6. Maintenance

**Note:** Before actioning any maintenance programme observe the 'Safety information' in Section 1.

## Warning

The cover gasket contains a thin stainless steel support ring which may cause physical injury if not handled and disposed of carefully.

### 6.1 General information

Before undertaking any maintenance on the trap it must be isolated from both the supply line and return line and any pressure allowed to safely normalise to atmosphere. The trap should then be allowed to cool. When reassembling, ensure that all joint faces are clean.



Maintenance can be completed with the trap in the pipeline, once the safety procedures have been observed. It is recommended that new gaskets and spares are used whenever maintenance is undertaken. Ensure that the correct tools and necessary protective equipment are used at all times. When maintenance is complete open isolation valves slowly and check for leaks.

### 6.2 How to fit a new capsule and seat:

- Remove the cover (1) and spring (10) from the body (6) by unscrewing the cover bolts (7).
- Remove the capsule (2) and spacer plate (9).
- Unscrew the valve seat (3) from the body (6).
- Clean or replace the strainer screen (4).
- Replace the valve seat (3) and tighten to the recommended torque (see Table 1).
- It is recommended to fit a new cover gasket (5) reassemble the spacer plate (9) ensuring that it is located centrally on the valve seat (3).
- Reassemble the capsule (2), spring (10) and cover (1). Make sure the spring is positioned with the narrow end downwards.

**Note:** Care must be taken to ensure the cover bolts (7) are progressively tightened to the recommended torque (see Table 1).

**Table 1 Recommended tightening torques**

Item	Part	 or  mm	N m	(lbf ft)
3	Valve seat	17 A /F	50 - 55	(37 - 41)
7	Cover bolts	M8 x 25	14 - 18	(11 - 13)

### 6.3 How to clean or replace the strainer screen:

- Remove the cover (1) and spring (10) from the body (6) by unscrewing the cover bolts (7).
- Remove the capsule (2) and spacer plate (9).
- Unscrew the valve seat (3) from the body (6).
- Clean or replace the screen (4) as required.
- Replace the valve seat (3) and tighten to the recommended torque (see Table 1).
- It is recommended to fit a new cover gasket (5), reassemble the spacer plate (9) ensuring that it is located centrally on the valve seat (3).
- Reassemble the capsule (2), spring (10) and cover (1). Make sure the spring is positioned with the narrow end downwards.

**Note:** Care must be taken to ensure the cover bolts (7) are progressively tightened to the recommended torque (see Table 1).

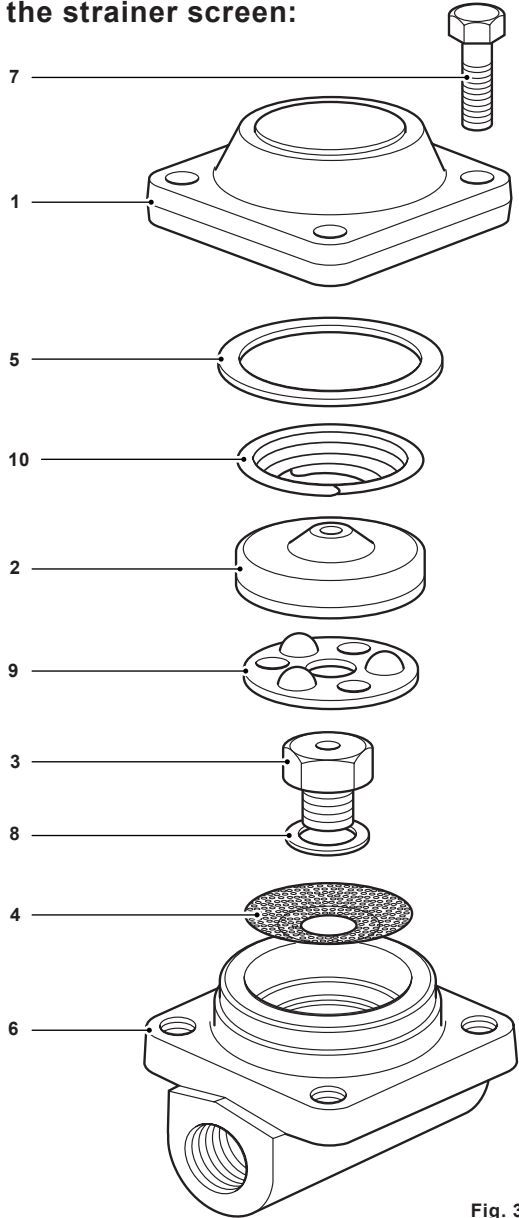

Fig. 3

# 7. Spare parts

## Spare parts

The spare parts available are shown in solid outline. Parts drawn in broken are not supplied as spares.

### Available spares

Capsule and seat assembly set	2, 3, 5, 8, 9, 10
Gasket set	5, 8
Strainer screen (packet of 3)	4

### How to order spares

Always order spares by using the description given in the column headed 'Available spares' and state the size and type of trap.

**Example:** 1 off Capsule and seat assembly set for a Spirax Sarco ½" BPM21L balanced pressure thermostatic steam trap having STD operation at 13 °C below steam saturation temperature.

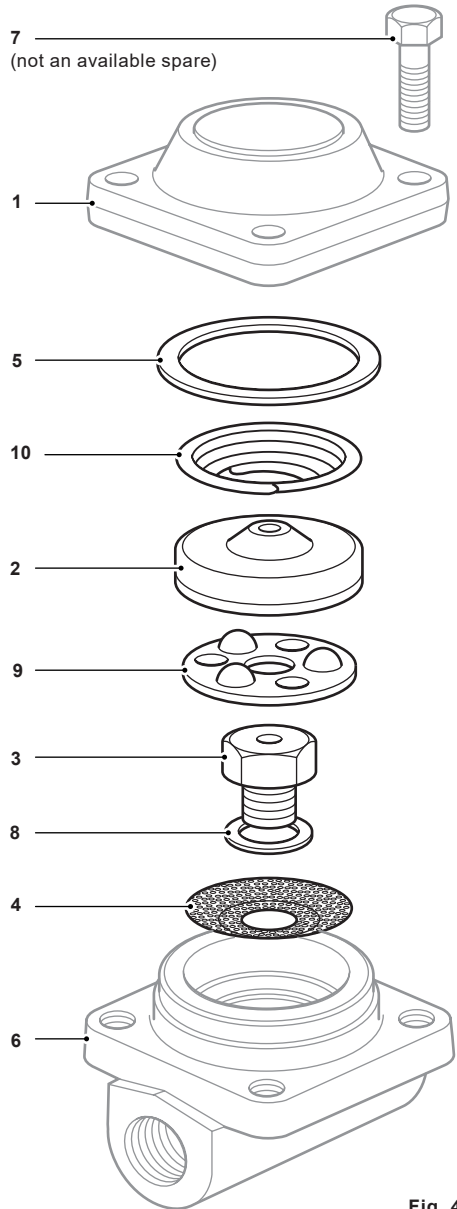

Fig. 4