

## **AVM7 and AVM7 Food+** **Balanced Pressure Thermostatic Air Vent** Installation and Maintenance Instructions

---

---

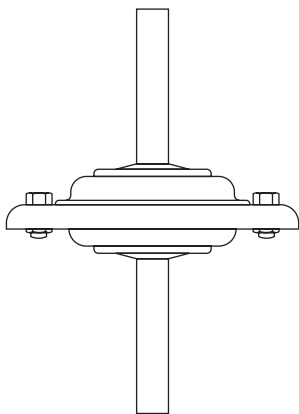

**Tube ended variant**

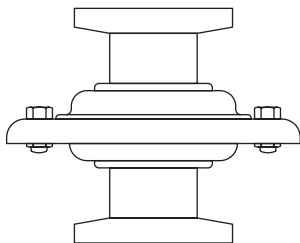

**Sanitary clamp ended  
variant**

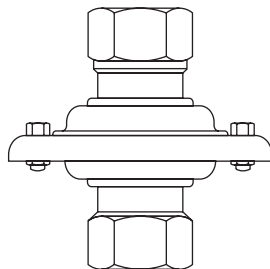

**Screwed ended  
variant**

1. Safety information
2. General product information
3. Installation
4. Commissioning
5. Operation
6. Maintenance
7. Spare parts

# 1. Safety information

Safe operation of this product can only be guaranteed if it is properly installed, commissioned, used and maintained by qualified personnel (see Section 1.11) in compliance with the operating instructions. General installation and safety instructions for pipeline and plant construction, as well as the proper use of tools and safety equipment must also be complied with.

## 1.1 Intended use

Referring to the Installation and Maintenance Instructions, name-plate and Technical Information Sheet, check that the product is suitable for the intended use/application.

The product listed below complies with the requirements of the EU Pressure Equipment Directive/UK Pressure Equipment (Safety) Regulations and carries the  mark when so required.

The product falls within the following EU Pressure Equipment Directive/UK Pressure Equipment (Safety) Regulations categories:

Product	Group 2 Gases	Group 2 Liquids
AVM7	SEP	SEP

- i) The product has been specifically designed for use on steam, air or water/condensate which are in Group 2 of the above mentioned EU Pressure Equipment Directive/UK Pressure Equipment (Safety) Regulations.
- ii) Check material suitability, pressure and temperature and their maximum and minimum values. If the maximum operating limits of the product are lower than those of the system in which it is being fitted, or if malfunction of the product could result in a dangerous overpressure or overtemperature occurrence, ensure a safety device is included in the system to prevent such over-limit situations.
- iii) Determine the correct installation situation and direction of fluid flow.
- iv) Spirax Sarco products are not intended to withstand external stresses that may be induced by any system to which they are fitted. It is the responsibility of the installer to consider these stresses and take adequate precautions to minimise them.
- v) Remove protective covers from all connections and the protective film from all name-plates, where appropriate, before installation on steam or other high temperature applications.
- vi) The AVM7 Food+ is intended to be connected into a system that can operate an EC1935 compliant process. To minimise the risk of non-intentionally added substances in the system, it is essential that an appropriate CIP (cleaning in place) cycle is carried out by the end user prior to first use in a food contact application. A list of the materials that could come directly or indirectly into contact with foodstuffs can be found in the Declaration of Compliance available for this product.

## 1.2 Access

Ensure safe access and if necessary a safe working platform (suitably guarded) before attempting to work on the product. Arrange suitable lifting gear if required.

## 1.3 Lighting

Ensure adequate lighting, particularly where detailed or intricate work is required.

## 1.4 Hazardous liquids or gases in the pipeline

Consider what is in the pipeline or what may have been in the pipeline at some previous time. Consider: flammable materials, substances hazardous to health, extremes of temperature.

## 1.5 Hazardous environment around the product

Consider: explosion risk areas, lack of oxygen (e.g. tanks, pits), dangerous gases, extremes of temperature, hot surfaces, fire hazard (e.g. during welding), excessive noise, moving machinery.

## 1.6 The system

Consider the effect on the complete system of the work proposed. Will any proposed action (e.g. closing isolation valves, electrical isolation) put any other part of the system or any personnel at risk? Dangers might include isolation of vents or protective devices or the rendering ineffective of controls or alarms. Ensure isolation valves are turned on and off in a gradual way to avoid system shocks.

## 1.7 Pressure systems

Ensure that any pressure is isolated and safely vented to atmospheric pressure. Consider double isolation (double block and bleed) and the locking or labelling of closed valves. Do not assume that the system has depressurised even when the pressure gauge indicates zero.

## 1.8 Temperature

Allow time for temperature to normalise after isolation to avoid danger of burns.

If parts made from FKM have been subjected to a temperature above 250 °C (482 °F), it may have decomposed and formed fluorine compounds, fluoro hydrocarbons and fluoro olefins. When subjected to temperatures above 500 °C (932 °F) parts made from FKM may ignite. Combustion residues are very corrosive and acidic, so acid-resistant gloves should be worn when handling, and calcium oxide/hydroxide can be used to neutralise it.

## 1.9 Tools and consumables

Before starting work ensure that you have suitable tools and/or consumables available. Use only genuine Spirax Sarco replacement parts.

## 1.10 Protective clothing

Consider whether you and/or others in the vicinity require any protective clothing to protect against the hazards of, for example, chemicals, high/low temperature, radiation, noise, falling objects, and dangers to eyes and face.

## 1.11 Permits to work

All work must be carried out or be supervised by a suitably competent person. Installation and operating personnel should be trained in the correct use of the product according to the Installation and Maintenance Instructions. Where a formal 'permit to work' system is in force it must be complied with. Where there is no such system, it is recommended that a responsible person should know what work is going on and, where necessary, arrange to have an assistant whose primary responsibility is safety. Post 'warning notices' if necessary.

## 1.12 Handling

Manual handling of large and/or heavy products may present a risk of injury. Lifting, pushing, pulling, carrying or supporting a load by bodily force can cause injury particularly to the back. You are advised to assess the risks taking into account the task, the individual, the load and the working environment and use the appropriate handling method depending on the circumstances of the work being done.

## 1.13 Residual hazards

In normal use the external surface of the product may be very hot. If used at the maximum permitted operating conditions the surface temperature of some products may reach temperatures in excess of 300 °C (572 °F).

Many products are not self-draining. Take due care when dismantling or removing the product from an installation (refer to 'Maintenance instructions').

## 1.14 Freezing

Provision must be made to protect products which are not self-draining against frost damage in environments where they may be exposed to temperatures below freezing point.

## 1.15 Disposal

Unless otherwise stated in the Installation and Maintenance Instructions, this product is recyclable and no ecological hazard is anticipated with its disposal providing due care is taken, except:

### FKM:

- Can be landfilled, when in compliance with National and Local regulations (waste code no.57502 - rubber waste; Germany).
- Can be incinerated when in compliance with National and Local regulations.
- Is insoluble in water.
- Is soluble in aromatic hydrocarbons.

Please visit the Spirax Sarco product compliance web pages

<https://www.spiraxsarco.com/product-compliance>

for up to date information on any substances of concern that may be contained within this product.

Where no additional information is provided on the Spirax Sarco product compliance web page, this product may be safely recycled and/or disposed providing due care is taken.

Always check your local recycling and disposal regulations.

## 1.16 Returning products

Customers and stockists are reminded that under EC Health, Safety and Environment Law, when returning products to Spirax Sarco they must provide information on any hazards and the precautions to be taken due to contamination residues or mechanical damage which may present a health, safety or environmental risk. This information must be provided in writing including Health and Safety data sheets relating to any substances identified as hazardous or potentially hazardous.

## 2. General product information

### 2.1 General description

The AVM7 is a clean (chemical-free) maintainable thermostatic air vent designed to remove air and other non-condensable gases from clean steam systems. Manufactured in 316L stainless steel with minimal crevices, and a typical internal surface finish of 1.6 - 3.2  $\mu\text{m}$  Ra the AVM7 operates close to steam temperature. Each trap is individually packaged within an 'ISO CLASS 7' clean environment with protective end caps and sealed in a protective plastic bag.

The AVM7 Food+ is designed, manufactured and approved for Steam and Condensate applications. This product complies with EC1935:2004 Food Contact Materials. It also complies with regulation EC2023:2006 on good manufacturing practice for materials and articles intended to come into contact with food.

### Standards

- The AVM7 has been designed and manufactured in general accordance with ASME BPE standards.
- The unit also complies with the requirements of the EU Pressure Equipment Directive/UK Pressure Equipment (Safety) Regulations.
- FDA CFR Title 21. Paragraph 177. 2600.
- USP Class VI Biological Reactivity Cytotoxicity Testing In-Vivo <88> extracted at 121 °C for 1 hour.
- ADI Free (Animal Derived Ingredients) for materials used, manufacturing processes involved in producing the part.
- TSE/BSE Free as Certified.
- Full material lot number product traceability.

### Certification

This product is available with the following certification:

- EN 10204 3.1 Material Certification Pressure Retaining Parts - Chargeable.
- EN 10204 3.1 Material Certification for Wetted Parts including the WFI element fill (also available for element spares) - Chargeable.
- Typical Internal Surface Finish - F.O.C.
- Certificate of Compliance for FDA, USP Class VI Testing Statement, and ADI Free Statement - F.O.C.
- TSE-BSE Statement - F.O.C.
- EC1935:2004 Declaration of Compliance - F.O.C. (Food+ range only).
- (EC)2023:2006 Good Manufacturing Practice for Materials and Articles Intended to come into Contact with Food.
- Declaration of Conformity BS EN ISO 14644-1:2015 Class 7 Clean Room - F.O.C.
- Typical Test Report - F.O.C.

**Note:** All certification/inspection requirements must be stated at the time of order placement, and may be subject to additional cost as detailed above.

**Note:** for further product data see Technical Information Sheet TI-P123-22.

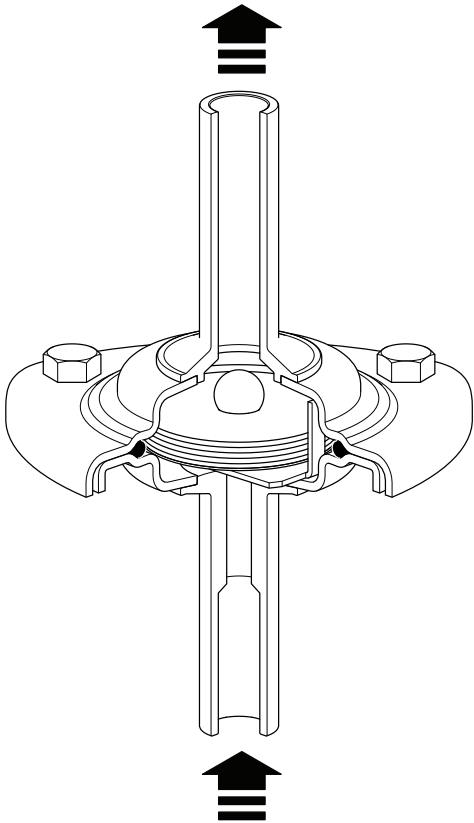

Fig. 1a Tube ended variant

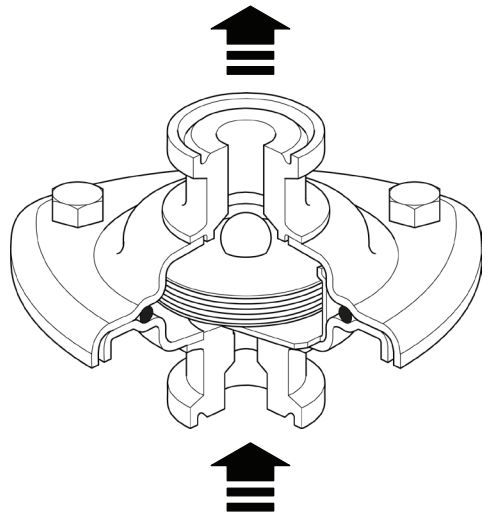

Fig. 1b Sanitary clamp ended variant

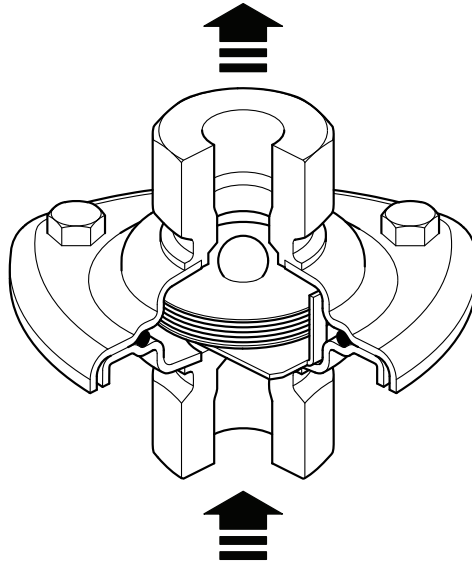

Fig. 1c Screwed ended variant

## 2.2 Sizes and pipe connections

	Standard	Issue	Type	Sizes				
Sanitary Clamp Ended Variants	ASME BPE		Type A			½"	¾"	
	ASME BPE		Type B					1"
Tube Ended Variants	Standard		Type	Sizes				
	Imperial		Wall 16 swg			½"	¾"	1"
	DIN11850	1999-01	Series-2		DN10	DN15		DN25
	ISO1127	1997	Series 1	DN8	DN10	DN15		
Screwed Ended Variants	Standard		Type	Sizes				
	Socket BSP Socket NPT				¼"	½"	¾"	1"

### Notes

1. On request other connection options are available at extra cost.
2. Please note that seat end spares for specially requested connections will require a minimum order quantity - Please consult Spirax Sarco for further information.
3. AVM7 Food+ is available with ½" BSP and ¾" BSP connections

## 2.3 Pressure/temperature limits

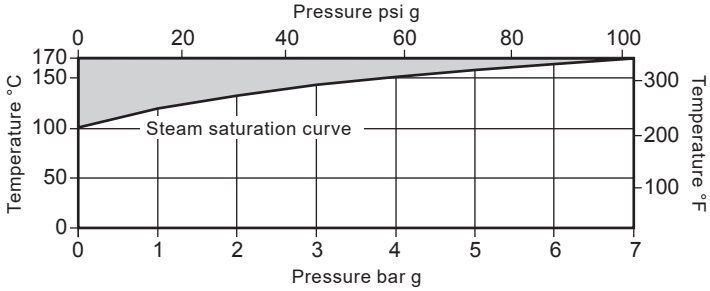

The product should not be used in this region as damage to the internals may occur

Body design conditions		PN7	
PMA	Maximum allowable pressure	7 bar g @ 170 °C	(101.5 psi g @ 338 °F)
TMA	Maximum allowable temperature	170 °C @ 7 bar g	(338 °F @ 101.5 psi g)
Minimum allowable temperature		-10 °C	(14 °F)
PMO	Maximum operating pressure for saturated steam service	7 bar g	(101.5 psi g)
TMO	Maximum operating temperature	170 °C	(338 °F)
Minimum operating temperature		0 °C	(32 °F)
Designed for a maximum cold hydraulic test pressure		10.7 bar g	(155.2 psi g)



## 3. Installation

**Note:** Before actioning any installation observe the 'Safety information' in Section 1.

Referring to the Installation and Maintenance Instructions, name-plate and Technical Information Sheet, check that the product is suitable for the intended installation:

- 3.1** Check materials, pressure and temperature and their maximum values. If the maximum operating limit of the product is lower than that of the system in which it is being fitted, ensure that a safety device is included in the system to prevent overpressurisation.
- 3.2** Determine the correct installation situation and the direction of fluid flow.
- 3.3** Remove protective covers from all connections and the protective film from all name-plates, where appropriate, before installation on steam or other high temperature applications.
- 3.4** The trap is designed to be fitted in vertical lines with flow upwards so that it can be self-draining. Check flow arrow for correct orientation. Fittings, clamps and gaskets for pipe end connections are not supplied. Do not expose the element to superheat conditions since over expansion may result. Installation should include a suitable cooling leg to avoid condensate back-up into process equipment under normal operating conditions.  
**Caution:** Do not overtighten clamp. This may cause the seal to spread/extrude and interface with element frame. It is normally only necessary to take up slack and tighten the nut by half a turn maximum.
- 3.5** If the trap is to be subjected to a hydraulic test at the full design pressure, before conducting the test, it is preferable to remove the internals to minimize the risk of damage.

**Caution:** In order to prevent undue stresses on the pipeline and air vent, ensure adequate provision is made for thermal expansion.

**Note:** The body and element must be handled carefully to ensure that surfaces are not damaged. If the trap is to discharge to atmosphere ensure it is to a safe place, the discharging fluid may be at a temperature of 100 °C (212 °F).

## 4. Commissioning

After installation or maintenance ensure that the system is fully functional. Carry out tests on any alarms or protective devices.

**Note:** As with all steam systems it is very important that the pressure is built up slowly to avoid possible damage to any sensitive equipment.

# 5. Operation

The operation relies on a stainless steel capsule that is filled with a WFI temperature sensing fluid. During cold or start-up conditions the capsule will be fully open allowing large volumes of air, condensate and/or CIP fluid to be drained. As the system approaches steam temperature the fluid in the capsule expands and the valve closes the trap to prevent live steam loss. This closure occurs very close to steam temperature to ensure efficient drainage of the system.

# 6. Maintenance

**Note:** Before actioning any maintenance program observe the 'Safety information' in Section 1.



## 6.1 General information

Before undertaking any maintenance on the product it must be isolated from the supply line and return line and any pressure allowed to safely normalise to atmosphere. The product should then be allowed to cool. When reassembling, ensure that all joint faces are clean. Always ensure the correct tools, safety procedures and protective equipment are used at all times.

## 6.2 How to fit new internals:

- Remove nuts and bolts.
- The end connection with internal seat, gasket and capsule assembly can then be removed for cleaning or replacement. Ensure that the capsule on reassembly is fitted in the correct position (see Figure 2).
- Reassemble using a new gasket and with the valve head in position to close onto the seat orifice.
- Replace nuts and bolts and tighten them to the recommended torque (see Table 1) and put back into service.
- Open isolation valves slowly until normal operating conditions are achieved.
- Check for leaks.

**Table 1 Recommended tightening torques**

Item	Part	 or mm		N m	(lbf ft)
5	Nuts and bolts	8 A/F	M5	3 - 4	(2.5 - 3.0)

# 7. Spare parts

Available spares are shown in solid outline. Parts drawn in a grey line are not available as spares.

## Available spares

Element assembly	2
'O' ring (packet of 3)	3

## How to order spares

Always order spares by using the description given in the column headed 'Available spares' and state the size, type and end connection of the unit.

**Example:** 1 - Element assembly for a Spirax Sarco 1/2" AVM7 stainless steel thermostatic air vent having screwed NPT connections.

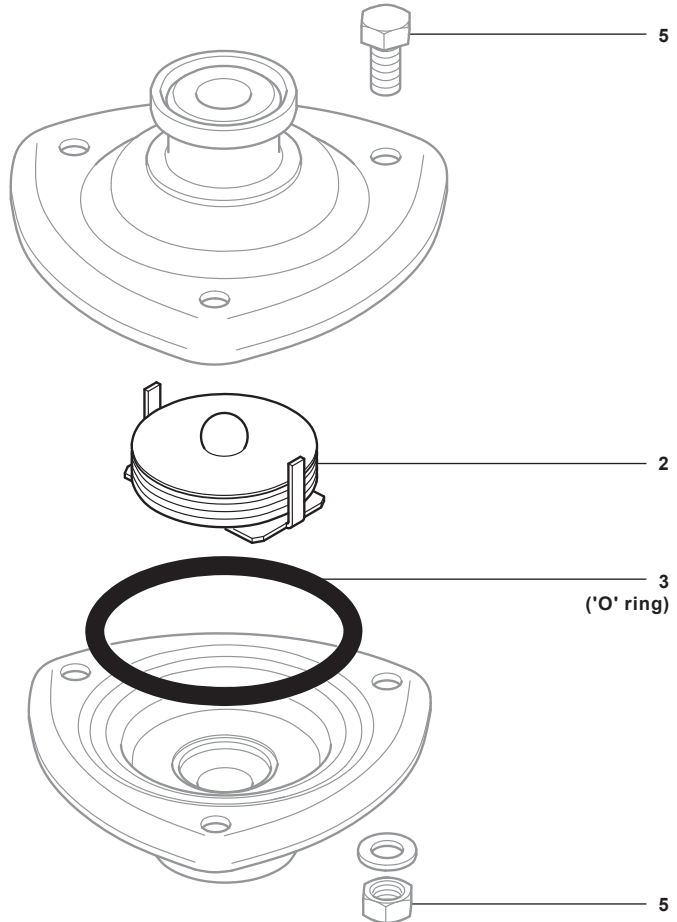

Fig. 2

AVM7 and AVM7 Food+ Balanced Pressure Thermostatic Air Vent

