

AVC32 Carbon Steel
Air Vent for Steam Systems
Installation and Maintenance Instructions

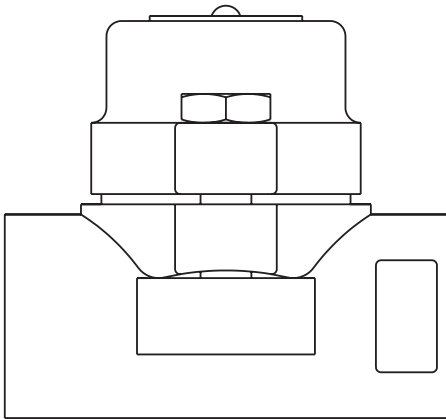

1. Safety information
2. General product information
3. Installation
4. Commissioning
5. Operation
6. Maintenance
7. Spare parts

1. Safety information

Safe operation of these products can only be guaranteed if they are properly installed, commissioned, used and maintained by qualified personnel (see Section 1.11 on this document) in compliance with the operating instructions. General installation and safety instructions for pipeline and plant construction, as well as the proper use of tools and safety equipment must also be complied with.

1.1 Intended use

Referring to the Installation and Maintenance Instructions, name-plate and Technical Information Sheet, check that the product is suitable for the intended use/application.

The products listed below comply with the requirements of the European Pressure Equipment Directive 2014/68/EU and carry the  mark when so required.

The products fall within the following Pressure Equipment Directive categories:

Product	Group 2 Gases	Group 2 Liquids
AVC32	SEP	SEP

- i) The products have been specifically designed for use on steam, air or water/condensate which are in Group 2 of the above mentioned Pressure Equipment Directive. The products' use on other fluids may be possible but, if this is contemplated, Spirax Sarco should be contacted to confirm the suitability of the product for the application being considered.
- ii) Check material suitability, pressure and temperature and their maximum and minimum values. If the maximum operating limits of the product are lower than those of the system in which it is being fitted, or if malfunction of the product could result in a dangerous overpressure or overtemperature occurrence, ensure a safety device is included in the system to prevent such over-limit situations.
- iii) Determine the correct installation situation and direction of fluid flow.
- iv) Spirax Sarco products are not intended to withstand external stresses that may be induced by any system to which they are fitted. It is the responsibility of the installer to consider these stresses and take adequate precautions to minimise them.
- v) Remove protection covers from all connections before installation.

1.2 Access

Ensure safe access and if necessary a safe working platform (suitably guarded) before attempting to work on the product. Arrange suitable lifting gear if required.

1.3 Lighting

Ensure adequate lighting, particularly where detailed or intricate work is required.

1.4 Hazardous liquids or gases in the pipeline

Consider what is in the pipeline or what may have been in the pipeline at some previous time. Consider: flammable materials, substances hazardous to health, extremes of temperature.

1.5 Hazardous environment around the product

Consider: explosion risk areas, lack of oxygen (e.g. tanks, pits), dangerous gases, extremes of temperature, hot surfaces, fire hazard (e.g. during welding), excessive noise, moving machinery.

1.6 The system

Consider the effect on the complete system of the work proposed. Will any proposed action (e.g. closing isolation valves, electrical isolation) put any other part of the system or any personnel at risk?

Dangers might include isolation of vents or protective devices or the rendering ineffective of controls or alarms. Ensure isolation valves are turned on and off in a gradual way to avoid system shocks.

1.7 Pressure systems

Ensure that any pressure is isolated and safely vented to atmospheric pressure. Consider double isolation (double block and bleed) and the locking or labelling of closed valves. Do not assume that the system has depressurised even when the pressure gauge indicates zero.

1.8 Temperature

Allow time for temperature to normalise after isolation to avoid danger of burns.

If parts made from Viton have been subjected to a temperature approaching 315 °C (599°F) or higher, it may have decomposed and formed hydrofluoric acid. Avoid skin contact and inhalation of any fumes as the acid will cause deep skin burns and damage the respiratory system.

If parts made from PTFE have been subjected to a temperature approaching 260 °C (500°F) or higher, they will give off toxic fumes, which if inhaled are likely to cause temporary discomfort. It is essential for a no smoking rule to be enforced in all areas where PTFE is stored, handled, or processed as persons inhaling the fumes from burning tobacco contaminated with PTFE particles can develop 'polymer fume fever'.

1.9 Tools and consumables

Before starting work ensure that you have suitable tools and/or consumables available. Use only genuine Spirax Sarco replacement parts.

1.10 Protective clothing

Consider whether you and/or others in the vicinity require any protective clothing to protect against the hazards of, for example, chemicals, high/low temperature, radiation, noise, falling objects, and dangers to eyes and face.

1.11 Permits to work

All work must be carried out or be supervised by a suitably competent person.

Installation and operating personnel should be trained in the correct use of the product according to the Installation and Maintenance Instructions.

Where a formal 'permit to work' system is in force it must be complied with. Where there is no such system, it is recommended that a responsible person should know what work is going on and, where necessary, arrange to have an assistant whose primary responsibility is safety.

Post 'warning notices' if necessary.

1.12 Handling

Manual handling of large and/or heavy products may present a risk of injury. Lifting, pushing, pulling, carrying or supporting a load by bodily force can cause injury particularly to the back. You are advised to assess the risks taking into account the task, the individual, the load and the working environment and use the appropriate handling method depending on the circumstances of the work being done.

1.13 Residual hazards

In normal use the external surface of the product may be very hot. If used at the maximum permitted operating conditions the surface temperature of some products may reach temperatures in excess of 300 °C (572 °F).

Many products are not self-draining. Take due care when dismantling or removing the product from an installation (refer to 'Maintenance instructions').

1.14 Freezing

Provision must be made to protect products which are not self-draining against frost damage in environments where they may be exposed to temperatures below freezing point.

1.15 Safety information - Product specific

See the relevant Sections of the attached Installation and Maintenance Instructions for specific details relating to these products.

1.16 Disposal

Unless otherwise stated in the Installation and Maintenance Instructions, this product is recyclable and no ecological hazard is anticipated with its disposal providing due care is taken, except:

-
- Viton:**
- Can be landfilled, when in compliance with National and Local regulations.
 - Can be incinerated, but a scrubber must be used to remove Hydrogen Flouride, which is evolved from the product and with compliance to National and Local regulations.
 - Is insoluble in aquatic media.
-
- PTFE:**
- Can only be disposed of by approved methods, not incineration.
 - Keep PTFE waste in a separate container do not mix it with other rubbish, and consign it to a landfill site.
-

Please visit the Spirax Sarco product compliance web pages <https://www.spiraxsarco.com/product-compliance> for up to date information on any substances of concern that may be contained within this product. Where no additional information is provided on the Spirax Sarco product compliance web page, this product may be safely recycled and/or disposed providing due care is taken. Always check your local recycling and disposal regulations.

1.17 Returning products

Customers and stockists are reminded that under EC Health, Safety and Environment Law, when returning products to Spirax Sarco they must provide information on any hazards and the precautions to be taken due to contamination residues or mechanical damage which may present a health, safety or environmental risk. This information must be provided in writing including Health and Safety data sheets relating to any substances identified as hazardous or potentially hazardous.

2. General product information

2.1 Description

The AVC32 is a carbon steel maintainable balanced pressure thermostatic air vent for use on steam systems. It has an integral flat strainer screen and straight connections. All pressure bearing components are produced by TÜV approved suppliers in accordance with AD-Merkblatt WO/TRD100.

Standards

This product fully complies with the requirements of the European Pressure Equipment Directive 2014/68/EU.

Certification

This product is available with certification to EN 10204 3.1.B.

Note: All certification/inspection requirements must be stated at the time of order placement.

Note: For additional information see Technical Information Sheet TI-P123-15.

2.2 Sizes and pipe connections

½", ¾" and 1" screwed BSP T Rp (ISO 7-1) or NPT.

½", ¾" and 1" socket weld ends to BS 3799.

½", ¾" and 1" butt weld ends to EN 12627.

DN15, DN20 and DN25 standard flange to EN 1092 PN40

ANSI B 16.5 Class 150 and 300, JIS/KS 10K and JIS/KS 20K.

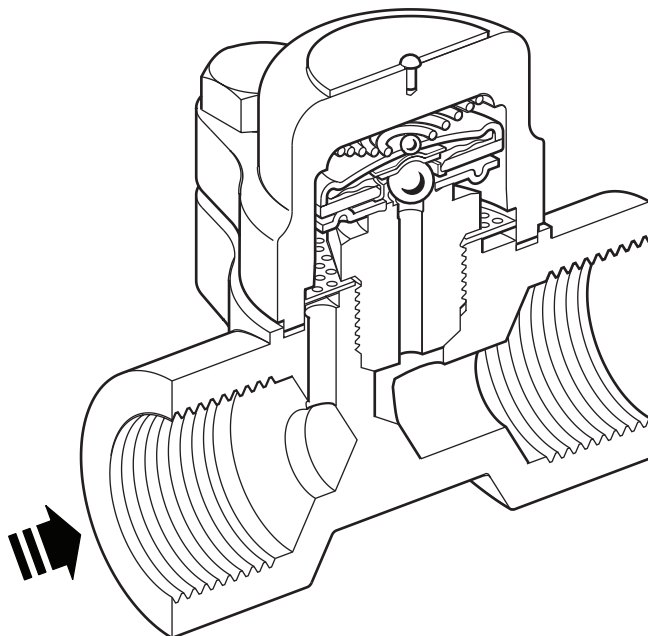
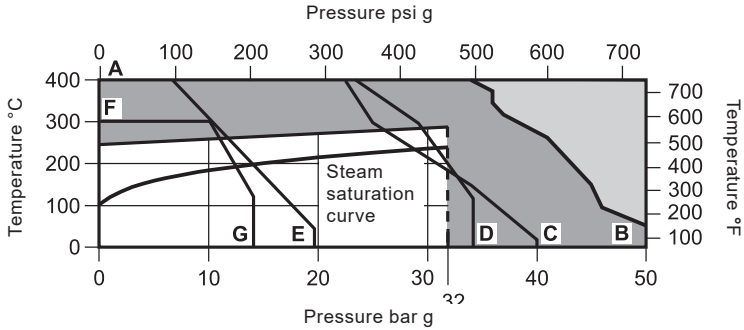



Fig. 1 AVC32

2.3 Pressure/temperature (ISO 6552)



 The product **must not** be used in this region.

 The product should not be used in this region or beyond its operating range as damage to the internals may occur.

- A - B** Screwed, socket weld, butt weld and flanged ANSI 300.
- A - C** Flanged EN 1092 PN40.
- A - D** Flanged JIS/KS 20K.
- A - E** Flanged ANSI 150.
- F - G** Flanged JIS/KS 10K.

Body design conditions	PN40	
PMA Maximum allowable pressure	50 bar g @ 50 °C	(725 psi g @ 122°F)
TMA Maximum allowable temperature	400 °C @ 35 bar g	(752 °F @ 507 psi g)
Minimum allowable temperature	-200 °C	(-328 °F)
PMO Maximum operating pressure for saturated steam service	32 bar g	(464 psi g)
TMO Maximum operating temperature	287 °C @ 32 bar g	(549 °F @ 464 psi g)
Minimum operating temperature	0 °C	(32 °F)
Note: For lower operating temperatures consult Spirax Sarco.		
Product safe for use under full vacuum conditions		
Designed for a maximum cold hydraulic test pressure of:	75 bar g	(1088 psi g)

3. Installation

Note: Before actioning any installation observe the 'Safety information' in Section 1.

Referring to the Installation and Maintenance Instructions, name-plate and Technical Information Sheet, check that the product is suitable for the intended installation:

- 3.1** Check materials, pressure and temperature and their maximum values. If the maximum operating limit of the product is lower than that of the system in which it is being fitted, ensure that a safety device is included in the system to prevent overpressurisation.
- 3.2** Determine the correct installation situation and the direction of fluid flow.
- 3.3** Remove protective covers from all connections and the protective film from all name-plates, where appropriate, before installation on steam or other high temperature applications.
- 3.4** The AVC32 should be installed with the capsule in a horizontal plane with the cap at the top, and be positioned at the highest point of the main, or plant where the air collects. For maximum removal of air the discharge should be as free as possible, piped to a safe location (see Figures 2 and 3).
- 3.5** **The air vent should not be insulated.**
- 3.6** **Welding into the pipeline** - There is no need to remove the operating capsule from the product providing the welding is performed using the electric arc method. For specific weld procedures consult the relevant National and International welding standards.
- 3.7** Ensure adequate space is left to remove the cover from the body for maintenance. Minimum withdrawal distance is 37 mm (1½").

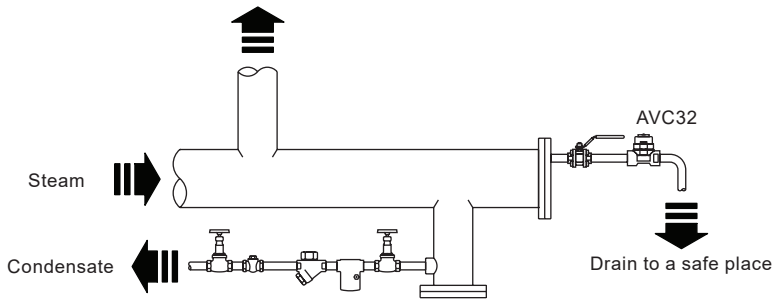

Fig. 2 Terminal end of distribution main

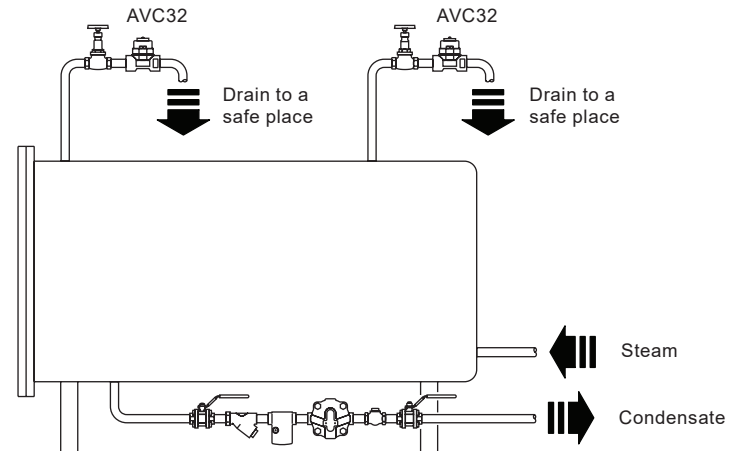

Fig. 3 Autoclave

4. Commissioning

After installation or maintenance ensure that the system is fully functional. Carry out tests on any alarms or protective devices.

5. Operation

The operating element is a capsule containing a small quantity of a special liquid with a boiling point below that of water. In the cold conditions that exist at start-up, the capsule is relaxed. The valve is off its seat and is wide open, allowing unrestricted removal of air. This is a feature of all balanced pressure traps/air vents and explains why they are well suited to air venting.

6. Maintenance

Note: Before actioning any maintenance programme observe the 'Safety information' in Section 1.

Warning

The body/cover gasket contains a thin stainless steel support ring which may cause physical injury if it is not handled and disposed of carefully.

6.1 General information

Before undertaking any maintenance on the air vent it must be isolated from the supply line, and any pressure allowed to safely normalise to atmosphere. The air vent should then be allowed to cool. When reassembling, ensure that all joint faces are clean.

Maintenance can be completed with the air vent in the pipeline, once the safety procedures have been observed. It is recommended that new gaskets and spares are used whenever maintenance is undertaken. Ensure that the correct tools and necessary protective equipment are used at all times. When maintenance is complete open the isolation valves slowly and check for leaks.

6.2 How to fit a new capsule and seat:

- Remove the cover (1) and spring (17) from the body (8) by unscrewing the two cover bolts (9).
- Remove the capsule (2) and spacer plate (18).
- Unscrew the valve seat (3) from the body (8).
- Clean or replace the strainer screen (5).
- Replace the valve seat (3) and tighten to the recommended torque (see Table 1).
- It is recommended to fit a new cover gasket (7) reassemble the spacer plate (18) ensuring that it is located centrally on the valve seat (3).
- Reassemble the capsule (2), spring (17) and cover (1).

Note: Care must be taken to ensure the cover bolts (9) are progressively tightened to the recommended torque (see Table 1).

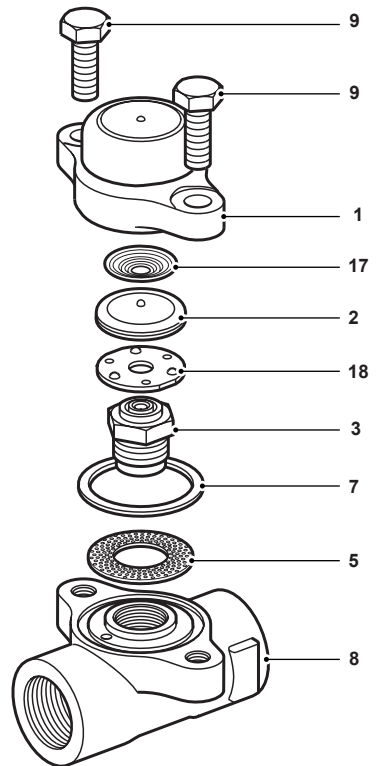

Fig. 4a

6.3 How to clean or replace the strainer screen:

- Remove the cover (1) and spring (17) from the body (8) by unscrewing the two cover bolts (9).
- Remove the capsule (2) and spacer plate (18).
- Unscrew the valve seat (3) from the body (8).
- Clean or replace the screen (5) as required.
- Replace the valve seat (3) and tighten to the recommended torque (see Table 1).
- It is recommended to fit a new cover gasket (7), reassemble the spacer plate (18) ensuring that it is located centrally on the valve seat (3).

Reassemble the capsule (2), spring (17) and cover (1).

Note: Care must be taken to ensure the cover bolts (9) are progressively tightened to the recommended torque (see Table 1).

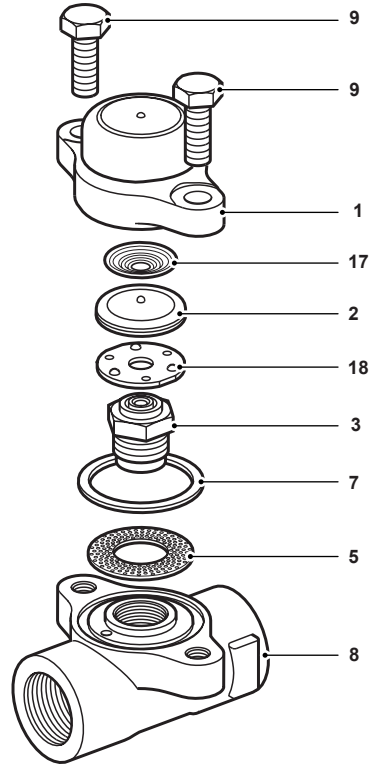



Fig. 4b

Table 1 Recommended tightening torques

Item	Part	 or mm		N m	(lbf ft)
3	Valve seat	24 A/F		115 - 125	(82 - 89)
9	Cover bolts	16 A/F	M10 x 30	23 - 27	(16 - 19)

7. Spare parts

The spare parts available are shown in heavy outline. Parts drawn in a grey line are not supplied as spares.

Available spares

Capsule and seat assembly set	2, 3, 17, 18
Strainer screen (packet of 3)	5
Set of cover gaskets (packet of 3)	7

How to order spares

Always order spares by using the description given in the column headed 'Available spares' and state the size and type of air vent.

Example: 1 - Capsule and seat assembly set for a Spirax Sarco DN25 AVC32 air vent.

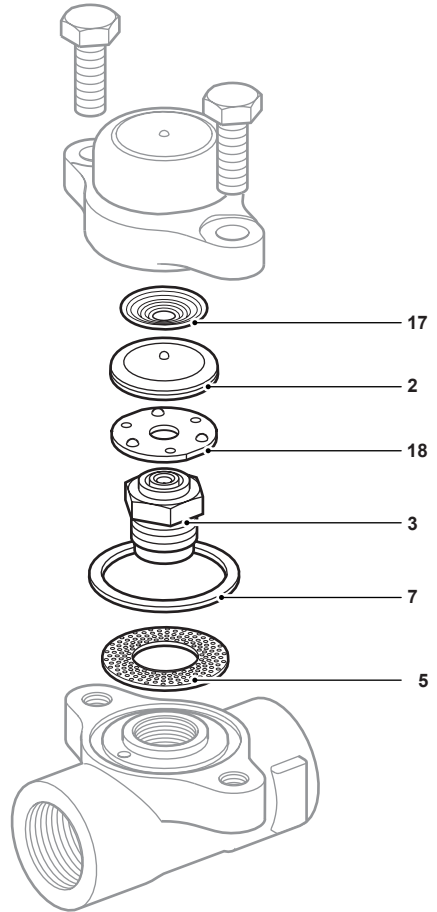

Fig. 5

