

AV45
Air Vent for Steam Systems
Installation and Maintenance Instructions

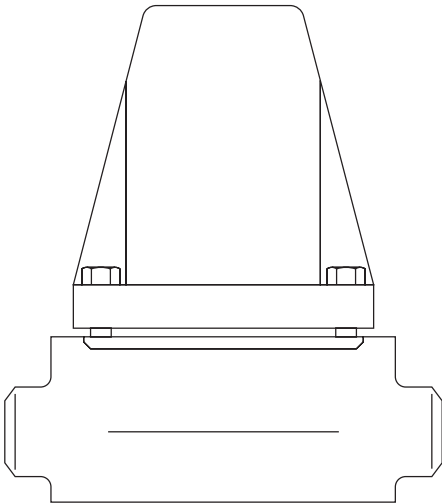

1. Safety information
2. General product information
3. Installation
4. Commissioning
5. Operation
6. Maintenance
7. Spare parts

1. Safety information

Safe operation of the unit can only be guaranteed if it is properly installed, commissioned and maintained by a qualified person (see Section 11 of the attached Supplementary Safety Information) in compliance with the operating instructions. General installation and safety instructions for pipeline and plant construction, as well as the proper use of tools and safety equipment must also be complied with.

Warning

The body/cover gasket contains a thin stainless steel support ring which may cause physical injury if it is not handled and disposed of carefully.

1.1 Intended use

Referring to the Installation and Maintenance Instructions, name-plate and Technical Information Sheet, check that the product is suitable for the intended use/application.

The product complies with the requirements of the EU Pressure Equipment Directive/UK Pressure Equipment (safety) Regulations and carry the   mark when so required:

- i) The product has been specifically designed for use on steam, air or water/condensate which are in Group 2 of the above mentioned Pressure Equipment Directive. The products use on other fluids may be possible but, if this is contemplated, Spirax Sarco should be contacted to confirm the suitability of the product for the application being considered.
- ii) Check material suitability, pressure and temperature and their maximum and minimum values. If the maximum operating limits of the product are lower than those of the system in which it is being fitted, or if malfunction of the product could result in a dangerous overpressure or overtemperature occurrence, ensure a safety device is included in the system to prevent such over-limit situations.
- iii) Determine the correct installation situation and direction of fluid flow.
- iv) Spirax Sarco products are not intended to withstand external stresses that may be induced by any system to which they are fitted. It is the responsibility of the installer to consider these stresses and take adequate precautions to minimise them.
- v) Remove protection covers from all connections and protective film from all name-plates, where appropriate, before installation on steam or other high temperature applications.

1.2 Access

Ensure safe access and if necessary a safe working platform (suitably guarded) before attempting to work on the product. Arrange suitable lifting gear if required.

1.3 Lighting

Ensure adequate lighting, particularly where detailed or intricate work is required.

1.4 Hazardous liquids or gases in the pipeline

Consider what is in the pipeline or what may have been in the pipeline at some previous time. Consider; flammable materials, substances hazardous to health, extremes of temperature.

1.5 Hazardous environment around the product

Consider; explosion risk areas, lack of oxygen (e.g. tanks, pits), dangerous gases, extremes of temperature, hot surfaces, fire hazard (e.g. during welding), excessive noise, moving machinery.

1.6 The system

Consider the effect on the complete system of the work proposed. Will any proposed action (e.g. closing isolation valves, electrical isolation) put any other part of the system or any personnel at risk?

Dangers might include isolation of vents or protective devices or the rendering ineffective of controls or alarms. Ensure isolation valves are turned on and off in a gradual way to avoid system shocks.

1.7 Pressure systems

Ensure that any pressure is isolated and safely vented to atmospheric pressure. Consider double isolation (double block and bleed) and the locking or labelling of closed valves. Do not assume that the system has depressurised even when the pressure gauge indicates zero.

1.8 Temperature

Allow time for temperature to normalise after isolation to avoid danger of burns.

1.9 Tools and consumables

Before starting work ensure that you have suitable tools and/or consumables available. Use only genuine Spirax Sarco replacement parts.

1.10 Protective clothing

Consider whether any protective clothing is required by yourself and/or others in the vicinity to protect against the hazards of, for example, chemicals, high/low temperature, radiation, noise, falling objects, and dangers to eyes and face.

1.11 Permits to work

All work must be carried out or be supervised by a suitably competent person.

Installation and operating personnel should be trained in the correct use of the product according to these instructions.

Where a formal 'permit to work' system is in force it must be complied with. Where there is no such system, it is recommended that a responsible person should know what work is going on and, where necessary, arrange to have an assistant whose primary responsibility is safety.

Post 'warning notices' if necessary.

1.12 Handling

Manual handling of Spirax-Sarco products may present a risk of injury. Lifting, pushing, pulling, carrying or supporting a load by bodily force can cause injury particularly to the back. You are advised to assess the risks taking into account the task, the individual, the load and the working environment and use the appropriate handling method depending on the circumstances of the work being done.

1.13 Residual hazards

In normal use the external surface of the product may be very hot. If used at the maximum permitted operating conditions the surface temperature of some products may reach temperatures in excess of 250 °C (482 °F).

This product is not self-draining. Take due care when dismantling or removing the product from an installation (refer to 'Maintenance instructions').

1.14 Freezing

Provision must be made to protect products which are not self-draining against frost damage in environments where they may be exposed to temperatures below freezing point.

1.15 Disposal

This product is recyclable and no ecological hazard is anticipated with its disposal providing due care is taken.

Please visit the Spirax Sarco product compliance web pages

<https://www.spiraxsarco.com/product-compliance>

for up to date information on any substances of concern that may be contained within this product. Where no additional information is provided on the Spirax Sarco product compliance web page, this product may be safely recycled and/or disposed providing due care is taken. Always check your local recycling and disposal regulations.

1.16 Returning products

Customers and stockists are reminded that under UK and EC Health, Safety and Environment Law, when returning products to Spirax Sarco they must provide information on any hazards and the precautions to be taken due to contamination residues or mechanical damage which may present a health, safety or environmental risk. This information must be provided in writing including Health and safety data sheets relating to any substances identified as hazardous or potentially hazardous.

2. General product information

2.1 General description

The AV45 is a forged alloy steel, medium pressure, temperature sensitive, maintainable air vent. The operating element comprises a stack of bimetals discs which control the flow of air and other incondensable gases at a preset temperature below steam saturation. It is also available with integral flanges.

Note: For additional information see the Technical Information Sheet, TI-P123-03.

2.2 Sizes and pipe connections

1/2", 3/4", 1" and 1 1/2" screwed BSP or NPT. Butt weld to suit schedule 80 pipe and socket weld to BS 3799 Class 3000.

DN15, 20, 25 and 40, standard flange to EN1092 PN63, ANSI 300 and JIS/KS 30K.

Fig. 1
AV45 (Butt weld version shown)

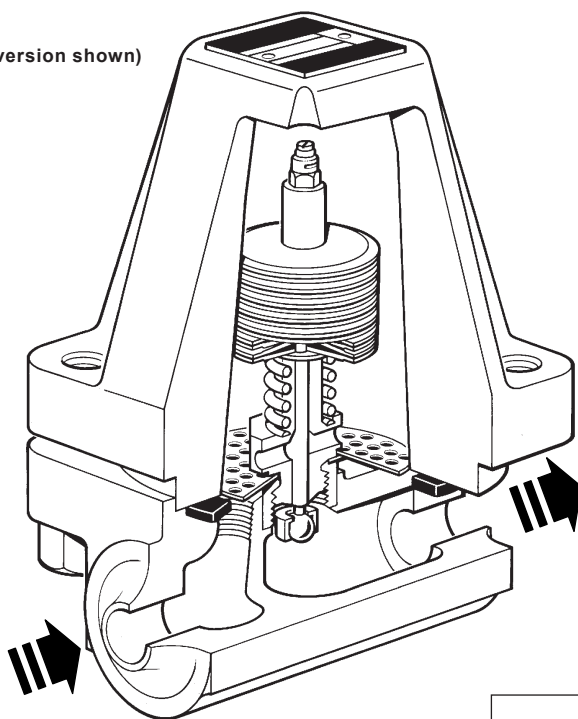

The main illustration shows the valve arrangement for the 3/4", 1" and 1 1/2" sizes.

For 1/2" sizes the valve arrangement differs as shown opposite.

AV45 Air Vent for Steam Systems

spirax
sarco

2.3 Pressure/temperature limits (ISO 6552)

Screwed, Socket weld, Butt weld

Flanged: EN 1092 PN63

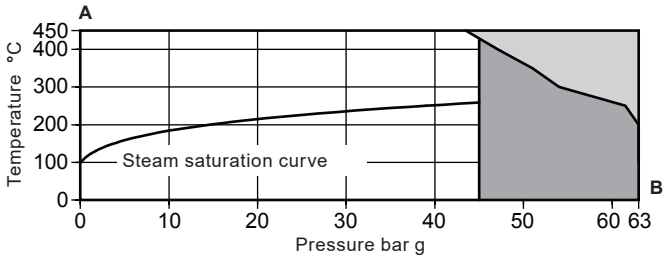

 The product **must not** be used in this region or beyond the parameter of the PMA or TMA of the relative end connection.

 The product should not be used in this region as damage to the internals may occur.

	Body design condition	PN63
	PMA Maximum allowable pressure	63 bar g @ 200 °C
	TMA Maximum allowable temperature	450 °C @ 43.5 bar g
	Minimum allowable temperature	-10 °C
A - B	PMO Maximum operating pressure for saturated steam service	45 bar g @ 259 °C
	TMO Maximum operating temperature	450 °C @ 43.5 bar g
	Minimum operating temperature	0 °C
	Designed for a maximum cold hydraulic test pressure of:	95 bar g

2.3 Pressure/temperature limits (ISO 6552) (continued)

Flanged: ASME 300

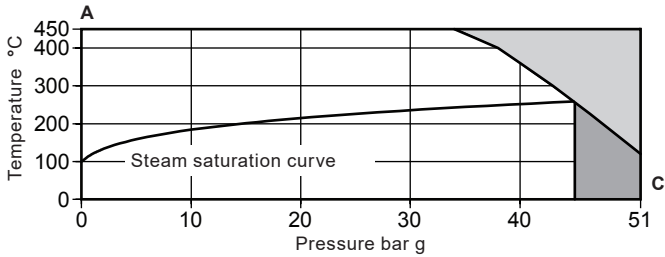

The product **must not** be used in this region or beyond the parameter of the PMA or TMA of the relative end connection.

The product should not be used in this region as damage to the internals may occur.

	Body design condition	ASME 300
	PMA Maximum allowable pressure	51 bar g @ 120 °C
	TMA Maximum allowable temperature	450 °C @ 34 bar g
	Minimum allowable temperature	-10 °C
A - C	PMO Maximum operating pressure for saturated steam service	45 bar g @ 259 °C
	TMO Maximum operating temperature	450 °C @ 34 bar g
	Minimum operating temperature	0 °C
	Designed for a maximum cold hydraulic test pressure of:	72 bar g

2.3 Pressure/temperature limits (ISO 6552) (continued)

Flanged: JIS/KS 30K

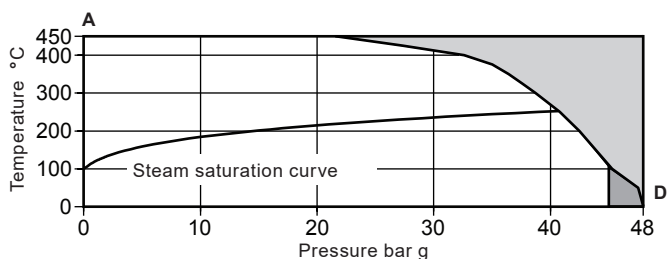

The product **must not** be used in this region or beyond the parameter of the PMA or TMA of the relative end connection.

The product should not be used in this region as damage to the internals may occur.

	Body design condition	JIS/KS 30K
A - D	PMA Maximum allowable pressure	48 bar g @ 0 °C
	TMA Maximum allowable temperature	450 °C @ 22 bar g
	Minimum allowable temperature	-10 °C
	PMO Maximum operating pressure for saturated steam service	45 bar g @ 100 °C
	TMO Maximum operating temperature	450 °C @ 22 bar g
	Minimum operating temperature	0 °C
	Designed for a maximum cold hydraulic test pressure of:	77 bar g

2.4 Kv values

Size	DN15 ½"	DN20 ¾"	DN25 1"	DN40 1½"	For conversion: Cv (UK) = Kv x 0.963 Cv (US) = Kv x 1.156
Kv value	0.25	0.6	0.6	0.6	

3. Installation

Note: Before actioning any installation observe the 'Safety information' in Section 1.

Referring to the Installation and Maintenance Instructions, name-plate and Technical Information Sheet, check that the product is suitable for the intended installation:

- 3.1** Check materials, pressure and temperature and their maximum values. If the maximum operating limit of the product is lower than that of the system in which it is being fitted, ensure that a safety device is included in the system to prevent overpressurisation.
- 3.2** Determine the correct installation situation and the direction of fluid flow.
- 3.3** Remove protective covers from all connections.
- 3.4** The AV45 is designed for installation with the element in a horizontal plane and the cover at the top. Positioned at the highest point of the main, or plant where air collects. For maximum air removal, the discharge should be as free as possible or piped to a safe location. When welding the trap into the line there is no need to remove the element providing that welding is done by the electric arc method.
- 3.5** The air vent should not be insulated.

4. Commissioning

After installation or maintenance ensure that the system is fully functional. Carry out tests on any alarms or protective devices.

5. Operation

The AV45 is a bimetallic air vent. This air vent operates on the basis of two opposing forces acting on the valve - an opening force created by the system pressure, and a closing force resulting from the steam temperature acting on the bimetallic elements. The AV45 quickly and automatically drains air and non-condensable gases on start-up, with no loss of steam.

6. Maintenance

Note: Before actioning any maintenance program observe the 'Safety information' in Section 1.

Warning

The body/cover gasket contains a thin stainless steel support ring which may cause physical injury if it is not handled and disposed of carefully.

6.1 General information



Before undertaking any maintenance on the AV45 it must be isolated from both the supply line and return line and any pressure allowed to safely normalise to atmosphere. The AV45 should then be allowed to cool. When reassembling, ensure that all joint faces are clean.

6.2 How to fit the element set:

Caution: Do not dismantle the element by removing the lock-nut (2) or the setting of the trap will be lost.

- Remove the cover from the body by unscrewing the nuts (11).
- Unscrew the element set (3, 4 and 6) and replace with the new one, coating the seat thread with a non-run silicon sealant such as Loctite Superflex Silicone Sealant White.
- Lightly coat the element seat gasket (6) with a suitable jointing compound.
- Replace the trap cover and the cover gasket (10) making sure that the strainer screen (4) is correctly located.
- Ensure that the cover nuts (11) are tightened evenly to the recommended tightening torque (see Table 1).

Table 1 Recommended tightening torques

Item	 or mm		N m	(lbf ft)
3	27 A/F		120 - 132	(89 - 97)
11	19 A/F	M10 xM12 30	110 - 120	(81 - 89)

7. Spare parts

The spare parts available are shown in heavy outline. Parts drawn in a grey line are not supplied as spares.

Available spares

Element set complete with valve, valve seat and valve seat gaskets	3, 6
Strainer screen (3 off)	4
Set of gaskets (packet of 3 of each)	6, 10

Note: The earlier design of AV45 incorporated 4 off long cover studs and 8 off washers and nuts for assembling the body and cover.

The current design of AV45 incorporates a threaded cover and 4 off shorter studs and 4 off washers and nuts.

How to order spares

Always order spares by using the description given in the column headed 'Available spares' and state the size and type of air vent.

Example: 1 off Element set for a Spirax Sarco 1" AV45 air vent.

