

---

**APT14, APT14HC and APT14SHC**  
**Spares 2**  
Installation and Maintenance Instructions

---

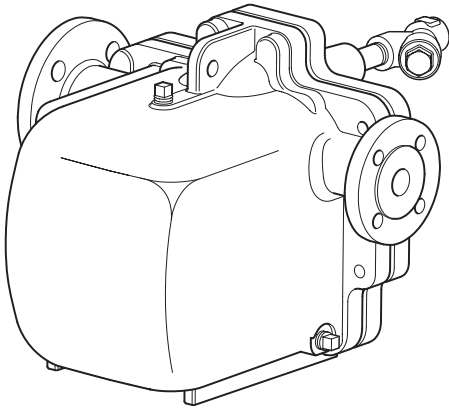

1. Safety information
2. Replacement of trap and outlet check valve mechanism
3. Replacement of Steam inlet / exhaust valves and seats



# 1. Safety information

Safe operation of these products can only be guaranteed if they are properly installed, commissioned, used and maintained by qualified personnel (see Section 1.11) in compliance with the operating instructions. General installation and safety instructions for pipeline and plant construction, as well as the proper use of tools and safety equipment must also be complied with.

## 1.1 Intended use

Referring to the Installation and Maintenance Instructions, name-plate and Technical Information Sheet, check that the product is suitable for the intended use/application.

The products listed below comply with the requirements of the European Pressure Equipment

Directive 2014/68/EU, and carry the  marks when so required.

The products fall within the following Pressure Equipment Directive categories:

Product	Group 2 Gases	Group 2 Liquids
APT14	1	SEP
APT14HC	2	SEP
APT14SHC	2	SEP
DCV10	DN40 PN25 rated	SEP
	DN50 Class 300 rated	1
Motive strainer	DN15	SEP

Product marking per ATEX Directive 94/9/EC  II 2G CT3.

- i) The product has been specifically designed for use on steam, compressed air and water/ condensate which are in Group 2 of the above mentioned Pressure Equipment Directive
- ii) Check material suitability, pressure and temperature and their maximum and minimum values. If the maximum operating limits of the product are lower than those of the system in which it is being fitted, or if malfunction of the product could result in a dangerous overpressure or overtemperature occurrence, ensure a safety device is included in the system to prevent such over-limit situations.
- iii) Determine the correct installation situation and direction of fluid flow.
- iv) Spirax Sarco products are not intended to withstand external stresses that may be induced by any system to which they are fitted. It is the responsibility of the installer to consider these stresses and take adequate precautions to minimise them.
- v) Remove protection covers from all connections and protective film from all name-plates, where appropriate, before installation on steam or other high temperature applications.

## 1.2 Access

Ensure safe access and if necessary a safe working platform (suitably guarded) before attempting to work on the product. Arrange suitable lifting gear if required.

## 1.3 Lighting

Ensure adequate lighting, particularly where detailed or intricate work is required.

## 1.4 Hazardous liquids or gases in the pipeline

Consider what is in the pipeline or what may have been in the pipeline at some previous time. Consider: flammable materials, substances hazardous to health, extremes of temperature.

## 1.5 Hazardous environment around the product

Consider: explosion risk areas, lack of oxygen (e.g. tanks, pits), dangerous gases, extremes of temperature, hot surfaces, fire hazard (e.g. during welding), excessive noise, moving machinery.

## 1.6 The system

Consider the effect on the complete system of the work proposed. Will any proposed action (e.g. closing isolation valves, electrical isolation) put any other part of the system or any personnel at risk?

Dangers might include isolation of vents or protective devices or the rendering ineffective of controls or alarms. Ensure isolation valves are turned on and off in a gradual way to avoid system shocks.

## 1.7 Pressure systems

Ensure that any pressure is isolated and safely vented to atmospheric pressure.

Consider double isolation (double block and bleed) and the locking or labelling of closed valves. Do not assume that the system has depressurised even when the pressure gauge indicates zero.

## 1.8 Temperature

Allow time for temperature to normalise after isolation to avoid danger of burns.

## 1.9 Tools and consumables

Before starting work ensure that you have suitable tools and/or consumables available. Use only genuine Spirax Sarco replacement parts.

## 1.10 Protective clothing

Consider whether you and/or others in the vicinity require any protective clothing to protect against the hazards of, for example, chemicals, high/low temperature, radiation, noise, falling objects, and dangers to eyes and face.

## 1.11 Permits to work

All work must be carried out or be supervised by a suitably competent person.

Installation and operating personnel should be trained in the correct use of the product according to the Installation and Maintenance Instructions.

Where a formal 'permit to work' system is in force it must be complied with. Where there is no such system, it is recommended that a responsible person should know what work is going on and, where necessary, arrange to have an assistant whose primary responsibility is safety and who has had specific training on pressurised systems.

Post 'warning notices' if necessary.

## 1.12 Handling

Manual handling of large and/or heavy products may present a risk of injury. Lifting, pushing, pulling, carrying or supporting a load by bodily force can cause injury particularly to the back. You are advised to assess the risks taking into account the task, the individual, the load and the working environment and use the appropriate handling method depending on the circumstances of the work being done.

## 1.13 Residual hazards

In normal use the external surface of the product may be very hot. If used at the maximum permitted operating conditions the surface temperature of these products may reach temperatures of 200 °C (392 °F).

These products are not self-draining. Take due care when dismantling or removing the product from an installation (refer to 'Maintenance instructions').

## 1.14 Freezing

Provision must be made to protect products which are not self-draining against frost damage in environments where they may be exposed to temperatures below freezing point.

## 1.15 Disposal

Unless otherwise stated in the Installation and Maintenance Instructions, this product is recyclable and no ecological hazard is anticipated with its disposal providing due care is taken.

Please visit the Spirax Sarco product compliance web pages

<https://www.spiraxsarco.com/product-compliance>

for up to date information on any substances of concern that may be contained within this product. Where no additional information is provided on the Spirax Sarco product compliance web page, this product may be safely recycled and/or disposed providing due care is taken. Always check your local recycling and disposal regulations.

## 1.16 Returning products

Customers and stockists are reminded that under EC Health, Safety and Environment Law, when returning products to Spirax Sarco they must provide information on any hazards and the precautions to be taken due to contamination residues or mechanical damage which may present a health, safety or environmental risk. This information must be provided in writing including Health and Safety data sheets relating to any substances identified as hazardous or potentially hazardous.

## 2. Replacement of trap (and outlet check valve - APT14 only) mechanism

### Important - safety note

Please read Section 1.12 regarding the safe lifting of this product before actioning any installation or maintenance procedure. Before any installation or maintenance procedure, always ensure that all steam or condensate lines are isolated. Ensure any residual internal pressure in the product or connecting lines is carefully relieved. Also ensure any hot parts have cooled to prevent risk of injury from burns. Always wear appropriate safety clothing before carrying out any installation or maintenance work. When dismantling this product, care should be taken to prevent injury from the snap action mechanism. Always handle with care.

### Replacement of trap (and outlet check valve - APT14 only) mechanism

Please ensure the safety recommendations are observed before commencing with any maintenance of this product.

### To fit the new trap (and outlet check valve - APT14) mechanism

1. Disconnect all connections to the cover. Remove the cover bolts using a 19 mm A/F socket, then carefully slide the cover assembly away from the body (a minimum withdrawal distance of 250 mm for the APT14 or 275 mm for the APT14HC and APT14SHC will be needed). Lift the cover assembly to a bench or other convenient working surface and clamp securely, avoiding contact with the gasket face.
2. Gently remove used gasket material from the body and cover being careful not to damage the gasket sealing faces.
3. Carefully fit a new gasket (item 2) into the existing body.
4. Remove split pin, washer and shaft from the trap pivot (V) (See Figure 1).
5. Remove split pin, washer and shaft from the trap 1st stage valve (W).
6. The floats and levers (items 5, 6, 7) can now be swung out of the way leaving access to the trap and check valve assembly.
7. Using the 4 mm Allen key unscrew the two M5 cap screws (item 21).
8. The whole trap (and check valve assembly APT14 only) can now be carefully withdrawn from the cover.
9. There are no serviceable parts within this assembly; the replacement spares kit contains all new parts.
10. Before fitting a new mechanism, clean the trap housing bore within the cover ensuring any sludge or scale is carefully removed and the 'O' ring sealing face is free from dirt.
11. Assembly is the opposite to removal, to ease fitting, the new 'O' ring must be lubricated with rubber lubricating emulsion such as International Products Corporation P-80.
12. Tighten the two M5 cap screws (item 21) to  $5 \pm 1$  N m ( $4 \pm 0.7$  lbf ft).
13. Refit the two shafts (V and W) (length 38 mm) - remembering to use new split pins and washers - to the trap housing (item 9) and trap 1st stage valve (item 22).
14. Move the floats to their upper and lower limits to ensure the trap mechanism operates smoothly and both the 1st stage and 2nd stage valves (items 22, 8) slide smoothly within their guides.

15. With the mechanism fully assembled, refit the cover assembly to the body, ensuring the gasket faces are carefully aligned and no parts of the gasket are trapped or pinched outside the sealing areas. To ensure accurate alignment of the cover and body, it is recommended the lower part of the cover's gasket seal is located into the body first. The top part of the seal can then be easily aligned.
  16. Refit the cover bolts ensuring they are sequentially tightened in opposing pairs, gradually increasing torque to  $63 \pm 5 \text{ N m}$  ( $46.5 \pm 4 \text{ lbf ft}$ ).
- | Bolt size | Socket size | Tightening torque                                      |
|-----------|-------------|--|
| M12 x 45  | 19 mm A/F   | $63 \pm 5 \text{ N m}$ ( $46.5 \pm 4 \text{ lbf ft}$ ) |
17. Carefully reconnect the motive steam supply and the exhaust lines to the connections marked (S) and (E). The APT14, APT14HC or APT14SHC is now ready to recommission.
  18. Make sure that the Spirax Sarco motive supply strainer (with 100 mesh screen) is reinstated to the motive supply connection (item 28).

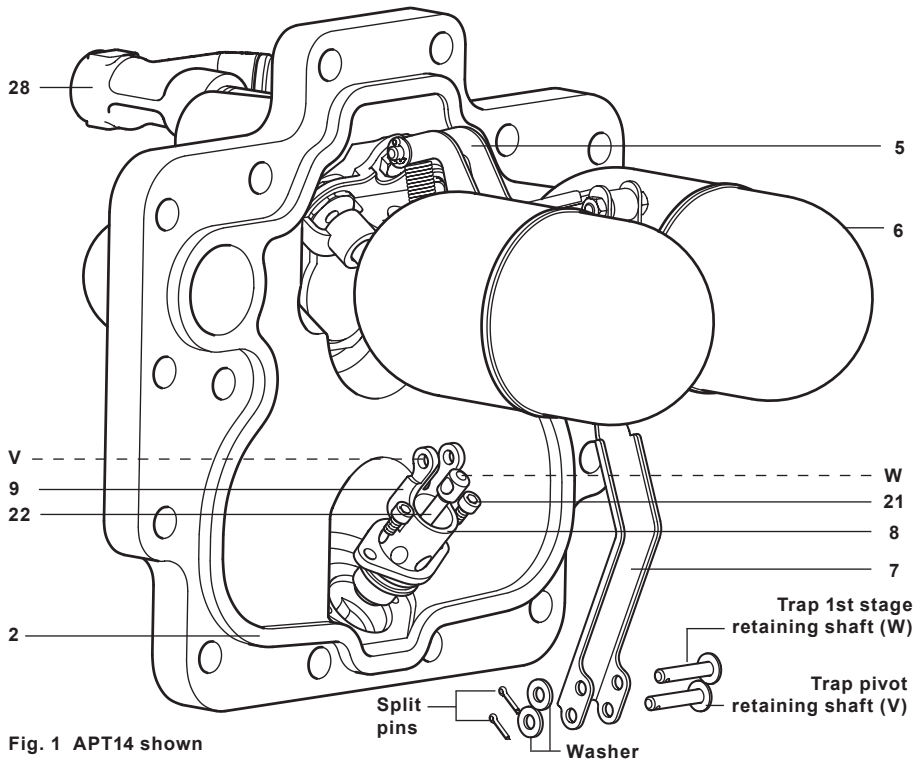

Fig. 1 APT14 shown

# 3. Replacement of steam inlet / exhaust valves and seats

Please ensure the safety recommendations are observed before commencing with any maintenance of this product.

## To replace the steam inlet and exhaust valve and seats

1. Remove the cover and old gasket (see cover gasket replacement procedure Section 7.1 of the full Installation and Maintenance Instructions IM-P612-04 as supplied with delivery of the whole unit - further copies are available on request through Spirax Sarco).
2. Lift the cover assembly to a bench or other convenient working surface and clamp securely, avoiding contact with the gasket face.
3. Carefully remove the circlip, washer and the inlet valve spring (item 27) from the end of the steam inlet valve (item 17).
4. Remove the three M8 bolts (items 20) using the 13 mm A/F socket.
5. Lift away the pump bracket assembly as this will allow access to the valve seats.
6. Using the 24 mm socket unscrew both the steam inlet and exhaust seats.
7. The seats, metal gaskets and steam inlet valve can now be removed.
8. Carefully clean the threads and gasket faces within the cover assembly ensuring all residues are removed.
9. Insert the replacement steam valve assembly (item 16 and item 17) according to Figure 2.
10. Place a new metal gasket (item 19) onto the threads of the seat before tightening into the cover.
11. Tighten the seat using the 24 mm socket to  $125 \pm 7$  N m ( $92 \pm 5$  lbf ft).
12. The exhaust seat can be replaced in a similar way.
13. Refit the bracket to the cover and tighten the three M8 bolts using the 13 mm A/F socket to  $18 \pm 2$  N m ( $13 \pm 1.5$  lbf ft).
14. It is important to ensure a new circlip is fitted to the steam inlet valve after the bracket has been bolted in place.
15. To remove the exhaust valve (item 18), remove split pins, washers, and shafts (X and Y) from the top spring pivot point and pump pivot point (See Figure 3).
16. Remove the spring and anchor assembly.
17. Draw the actuator arm with the exhaust valve downwards within its slots until it becomes free. It may be necessary to slide the exhaust valve backwards against its internal spring to free it from the pump bracket guide (item 13).
18. Remove the exhaust valve from the actuator arm.
19. **Fitting the replacement exhaust valve is the opposite to removal**, remembering to compress the small spring within the new valve before refitting to the spigot of the actuator arm.
20. Ensure the actuator is correctly aligned and located within the slots of the pump bracket (item 13).
21. Once this is correctly located, ensure the exhaust valve can slide easily within its guides.
22. When refitting the spring retaining shaft (Y) (30 mm long) and pump pivot retaining shaft (X) (52 mm long), always use new split pins and washers.



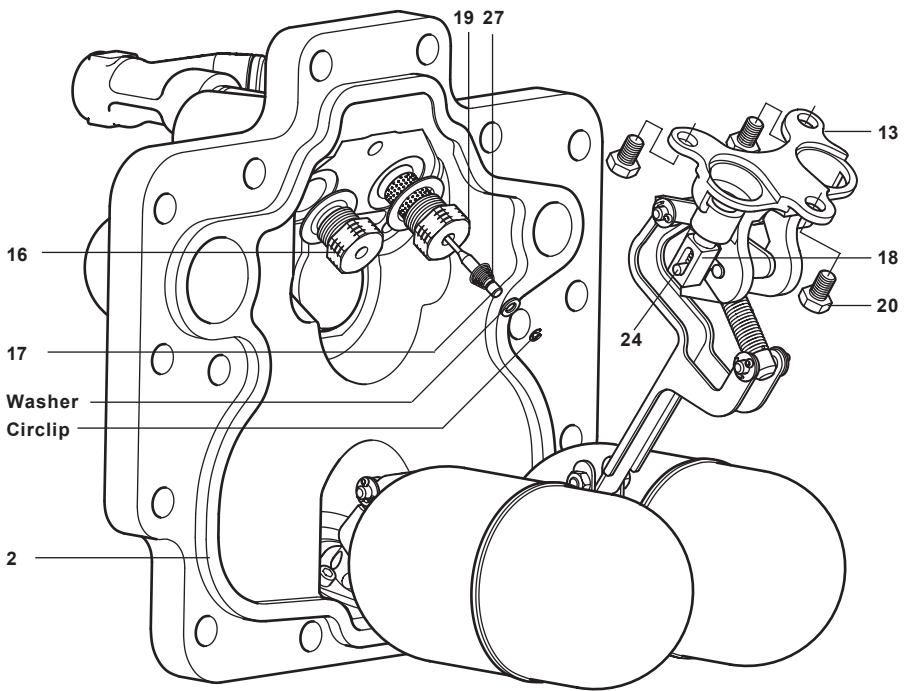

Fig. 2 APT14 shown

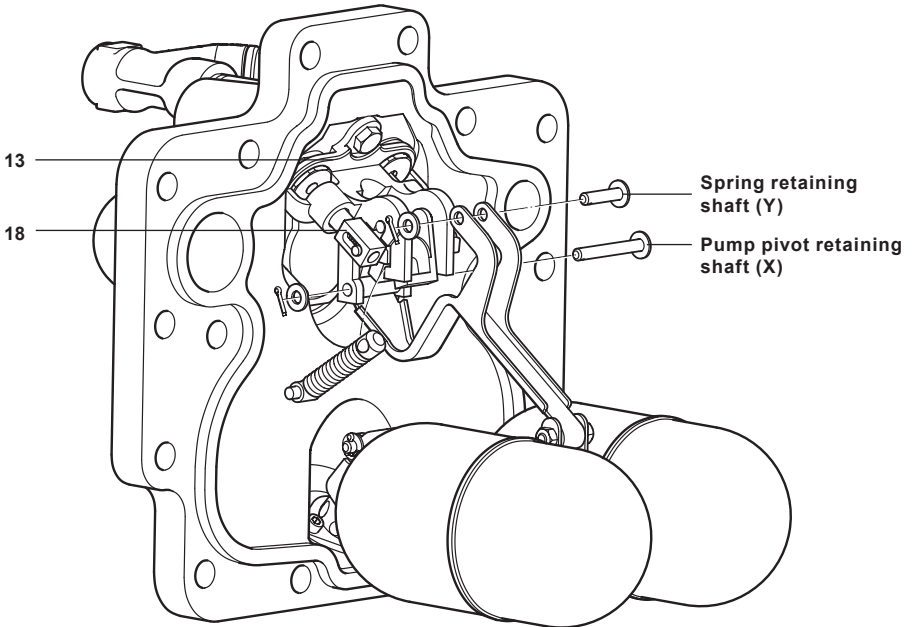

Fig. 3 APT14 shown

23. Check that the mechanism snaps over and opens and closes the valves by moving the floats to their upper and lower limits of travel.

**Note:** The valve gear has been designed to be adjustment-free, simplifying the fitting of new parts. If after assembly the mechanism does not operate correctly, check all the parts are assembled and aligned as per Figure 4.

24. With the mechanism fully assembled, refit the cover assembly to the body, ensuring the gasket faces are carefully aligned and no parts of the gasket are trapped or pinched outside the sealing areas. To ensure accurate alignment of the cover and body, it is recommended the lower part of the cover's gasket seal is located into the body first. The top part of the seal can then be easily aligned.
25. Refit the cover bolts ensuring they are sequentially tightened in opposing pairs, gradually increasing torque to  $63 \pm 5 \text{ N m}$  ( $46.5 \pm 4 \text{ lbf ft}$ ).
26. Carefully reconnect the motive steam supply and the exhaust lines to the connections marked (S) and (E). The APT14, APT14HC or APT14SHC is now ready to recommission.
27. Make sure that the Spirax Sarco motive supply strainer (with 100 mesh screen) is reinstated to the motive supply connection (item 28).

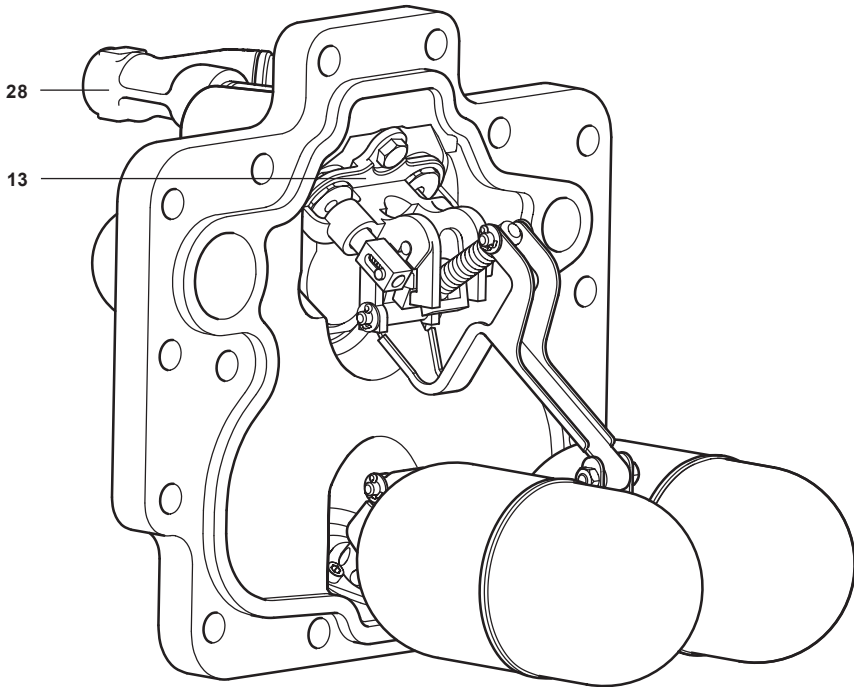

Fig. 4 APT14 shown



