

APT14, APT14HC and APT14SHC

Spares 1

Installation and Maintenance Instructions

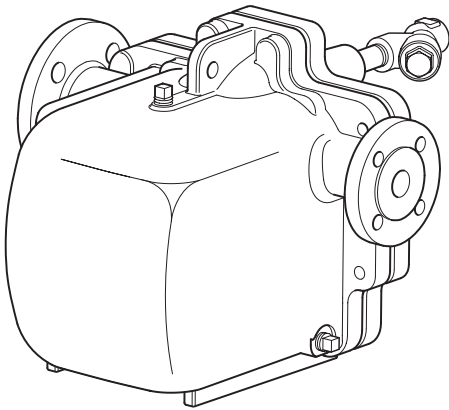



1. Safety information
2. Replacement of cover gasket
3. Replacement of inlet swing check valve
4. Replacement of spring and actuator arm
5. Replacement of floats

1. Safety information

Safe operation of these products can only be guaranteed if they are properly installed, commissioned, used and maintained by qualified personnel (see Section 1.11) in compliance with the operating instructions. General installation and safety instructions for pipeline and plant construction, as well as the proper use of tools and safety equipment must also be complied with.

1.1 Intended use

Referring to the Installation and Maintenance Instructions, name-plate and Technical Information Sheet, check that the product is suitable for the intended use/application.

The products listed below fully comply with the requirements of the European Pressure Equipment Directive 2014/68/EU, ATEX Directive 94/9/EC and carry the  and  marks when so required.

The products fall within the following Pressure Equipment Directive categories:

Product	Group 2 Gases	Group 2 Liquids
APT14	1	SEP
APT14HC	2	SEP
APT14SHC	2	SEP
DCV10	DN40 PN25 rated	SEP
	DN50 Class 300 rated	1
Motive strainer	DN15	SEP

Product marking per ATEX Directive 94/9/EC  II 2G CT3.

- i) The products have been designed for use on steam, air and water/condensate which are in Group 2 of the above mentioned Pressure Equipment Directive. The products' use on other fluids may be possible but, if this is contemplated, Spirax Sarco should be contacted to confirm the suitability of the product for the application being considered.
- ii) Check material suitability, pressure and temperature and their maximum and minimum values. If the maximum operating limits of the product are lower than those of the system in which it is being fitted, or if malfunction of the product could result in a dangerous overpressure or overtemperature occurrence, ensure a safety device is included in the system to prevent such over-limit situations.
- iii) Determine the correct installation situation and direction of fluid flow.
- iv) Spirax Sarco products are not intended to withstand external stresses that may be induced by any system to which they are fitted. It is the responsibility of the installer to consider these stresses and take adequate precautions to minimise them.
- v) Remove protection covers including cardboard support flanges from all connections before installation.

1.2 Access

Ensure safe access and if necessary a safe working platform (suitably guarded) before attempting to work on the product. Arrange suitable lifting gear if required.

1.3 Lighting

Ensure adequate lighting, particularly where detailed or intricate work is required.

1.4 Hazardous liquids or gases in the pipeline

Consider what is in the pipeline or what may have been in the pipeline at some previous time. Consider: flammable materials, substances hazardous to health, extremes of temperature.

1.5 Hazardous environment around the product

Consider: explosion risk areas, lack of oxygen (e.g. tanks, pits), dangerous gases, extremes of temperature, hot surfaces, fire hazard (e.g. during welding), excessive noise, moving machinery.

1.6 The system

Consider the effect on the complete system of the work proposed. Will any proposed action (e.g. closing isolation valves, electrical isolation) put any other part of the system or any personnel at risk? Dangers might include isolation of vents or protective devices or the rendering ineffective of controls or alarms. Ensure isolation valves are turned on and off in a gradual way to avoid system shocks.

1.7 Pressure systems

Ensure that any pressure is isolated and safely vented to atmospheric pressure. Consider double isolation (double block and bleed) and the locking or labelling of closed valves. Do not assume that the system has depressurised even when the pressure gauge indicates zero.

1.8 Temperature

Allow time for temperature to normalise after isolation to avoid danger of burns.

1.9 Tools and consumables

Before starting work ensure that you have suitable tools and/or consumables available. Use only genuine Spirax Sarco replacement parts.

1.10 Protective clothing

Consider whether you and/or others in the vicinity require any protective clothing to protect against the hazards of, for example, chemicals, high/low temperature, radiation, noise, falling objects, and dangers to eyes and face.

1.11 Permits to work

All work must be carried out or be supervised by a suitably competent person.

Installation and operating personnel should be trained in the correct use of the product according to the Installation and Maintenance Instructions.

Where a formal 'permit to work' system is in force it must be complied with. Where there is no such system, it is recommended that a responsible person should know what work is going on and, where necessary, arrange to have an assistant whose primary responsibility is safety.

Post 'warning notices' if necessary.

1.12 Handling

Manual handling of large and/or heavy products may present a risk of injury. Lifting, pushing, pulling, carrying or supporting a load by bodily force can cause injury particularly to the back. You are advised to assess the risks taking into account the task, the individual, the load and the working environment and use the appropriate handling method depending on the circumstances of the work being done.

Please note

For specific details relating to the weight and internal mechanism of these products, see IM-P612-04, Section 2 (please note that this document was originally supplied with delivery of the whole unit - further copies are available on request through Spirax Sarco).

Product specific - safe lifting information

Please note that the Spirax Sarco APT14 automatic pump trap units come complete with holes which may be tapped or untapped. These holes may be used for lifting purposes at the sole risk and responsibility of the purchaser.

The purchaser is responsible for the selection and use of the correct eye-bolt or shackle combination and is, in whole, responsible for all lifting operations and operator competency at their location. Spirax Sarco will ensure that any tapped hole will have a spot face larger than the shoulder of a standard eye-bolt to allow seating down to the shoulder. However, it should not be assumed that an eye-bolt is suitable for lifting the product simply on the basis of shoulder size.

Spirax Sarco will accept no responsibility for loss or damage real or imagined, caused by incorrect or inappropriate lifting of our products.

Spirax Sarco will ensure that the tapped holes provided are clearly marked with the exact size and thread form. We will also carry out in conjunction with a third party, a test on a sample of each product so provided and make available a copy of the test procedure and test certificate on request.

Furthermore and without obligation Spirax Sarco will attach to each product provided with such holes, threaded or otherwise, a disclaimer affixed to the product explaining the purchaser's duty under the LOLER regulations for safe off-loading and lifting of the product at their premises.

1.13 Residual hazards

In normal use the external surface of the product may be very hot. If used at the maximum permitted operating conditions the surface temperature of these products may reach temperatures of 200°C (392°F).

These products are not self-draining. Take due care when dismantling or removing the product from an installation (refer to 'Maintenance instructions').

1.14 Freezing

Provision must be made to protect products which are not self-draining against frost damage in environments where they may be exposed to temperatures below freezing point.

1.15 Disposal

Unless otherwise stated in the Installation and Maintenance Instructions, this product is recyclable and no ecological hazard is anticipated with its disposal providing due care is taken.

Please visit the Spirax Sarco product compliance web pages

<https://www.spiraxsarco.com/product-compliance>

for up to date information on any substances of concern that may be contained within this product. Where no additional information is provided on the Spirax Sarco product compliance web page, this product may be safely recycled and/or disposed providing due care is taken. Always check your local recycling and disposal regulations.

1.16 Returning products

Customers and stockists are reminded that under EC Health, Safety and Environment Law, when returning products to Spirax Sarco they must provide information on any hazards and the precautions to be taken due to contamination residues or mechanical damage which may present a health, safety or environmental risk. This information must be provided in writing including Health and Safety data sheets relating to any substances identified as hazardous or potentially hazardous.

2. Replacement of cover gasket

Important - safety note

Please read Section 1.12 regarding the safe lifting of this product before actioning any installation or maintenance procedure.

Before any installation or maintenance procedure, always ensure that all steam or condensate lines are isolated.

Ensure any residual internal pressure in the product or connecting lines is carefully relieved. Also ensure any hot parts have cooled to prevent risk of injury from burns.

Always wear appropriate safety clothing before carrying out any installation or maintenance work. When dismantling this product, care should be taken to prevent injury from the snap action mechanism.

Always handle with care.

Please ensure the safety recommendations are observed before commencing with any maintenance of this product.

To fit the new cover gasket

1. Disconnect all connections to the cover. Remove the cover bolts using the correct size socket, then carefully slide the cover assembly away from the body (a minimum withdrawal distance of 250 mm for the APT14 or 275 mm for the APT14HC and APT14SHC will be needed). Lift the cover assembly to a bench or other convenient working surface and clamp securely, avoiding contact with the gasket face.
2. Gently remove used gasket material from the body and cover, being careful not to damage the gasket sealing faces.
3. Carefully fit a new gasket (item 2) into the existing body (See Figure 2).
4. **Refit the cover assembly to the body**, ensuring the gasket faces are carefully aligned and no parts of the gasket are trapped or pinched outside the sealing areas. To ensure accurate alignment of the cover and body, it is recommended the lower part of the cover's gasket seal is located into the body first. The top part of the seal can then be easily aligned.
5. Refit the cover bolts ensuring they are sequentially tightened in opposing pairs, gradually increasing torque to 63 ± 5 N m (46.5 ± 4 lbf ft).

Bolt size	Socket size	Tightening torque
M12 x 45	19 mm A/F	63 ± 5 N m (46.5 ± 4 lbf ft)

6. Carefully reconnect the motive steam supply and the exhaust lines to the connections marked (S) and (E). The APT14, APT14HC or APT14SHC is now ready to recommission.
7. Make sure that the Spirax Sarco motive supply strainer (with 100 mesh screen) is reinstated to the motive supply connection (item 28, Figure 2).

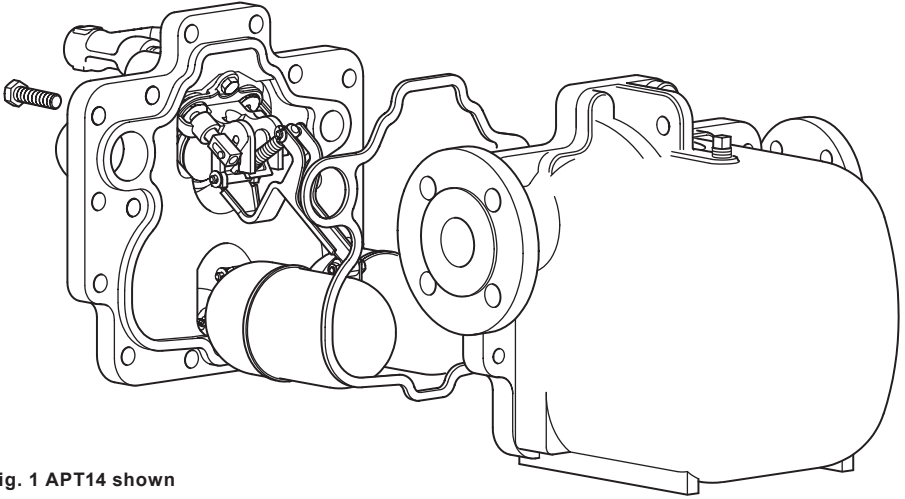

Fig. 1 APT14 shown

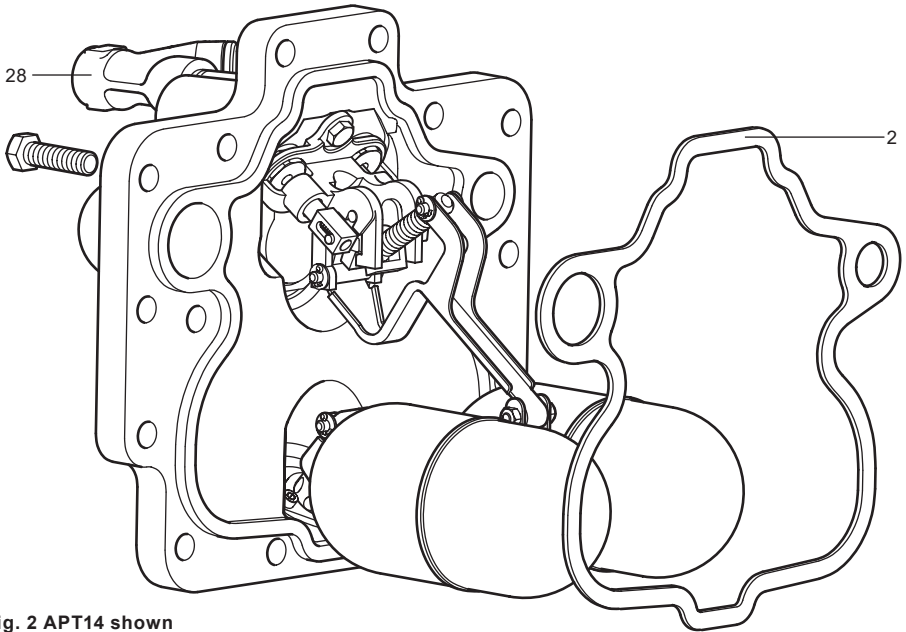

Fig. 2 APT14 shown

3. Replacement of inlet swing check valve

Please ensure the safety recommendations are observed before commencing with any maintenance of this product.

To replace the inlet swing check valve

1. Remove the cover and old gasket (see cover gasket replacement procedure, Section 2).
2. Lift the cover assembly to a bench or other convenient working surface and clamp securely, avoiding contact with the gasket face.
3. Carefully remove the circlip, washer and the inlet valve spring (item 27) from the end of the steam inlet valve (item 17).
4. Remove the three M8 bolts that secure the pump mechanism bracket using the 13 mm A/F socket.
5. Lift away the pump bracket assembly (See Figure 3). This will allow access to the inlet swing check valve (item 12).
6. The swing check valve flap can now easily be withdrawn.
7. Fit a new flap, ensuring the face of the check valve flap and seat are clean and free from damage.
8. **Reassembly is the opposite to removal.**
9. Tighten the three M8 bolts using the 13 mm A/F socket to 18 ± 2 N m (13 ± 1.5 lbf ft).
10. It is important to ensure a new circlip is refitted to the steam inlet valve.
11. With the mechanism fully assembled, refit the cover assembly to the body, ensuring the gasket faces are carefully aligned and no parts of the gasket are trapped or pinched outside the sealing areas. To ensure accurate alignment of the cover and body, it is recommended the lower part of the cover's gasket seal is located into the body first. The top part of the seal can then be easily aligned.
12. Refit the cover bolts ensuring they are sequentially tightened in opposing pairs, gradually increasing torque to 63 ± 5 N m (46.5 ± 4 lbf ft).
13. Carefully reconnect the motive steam supply and the exhaust lines to the connections marked (S) and (E). The APT14, APT14HC or APT14SHC is now ready to recommission.
14. Make sure that the Spirax Sarco motive supply strainer (with 100 mesh screen) is reinstated to the motive supply connection (item 28, Figure 3).

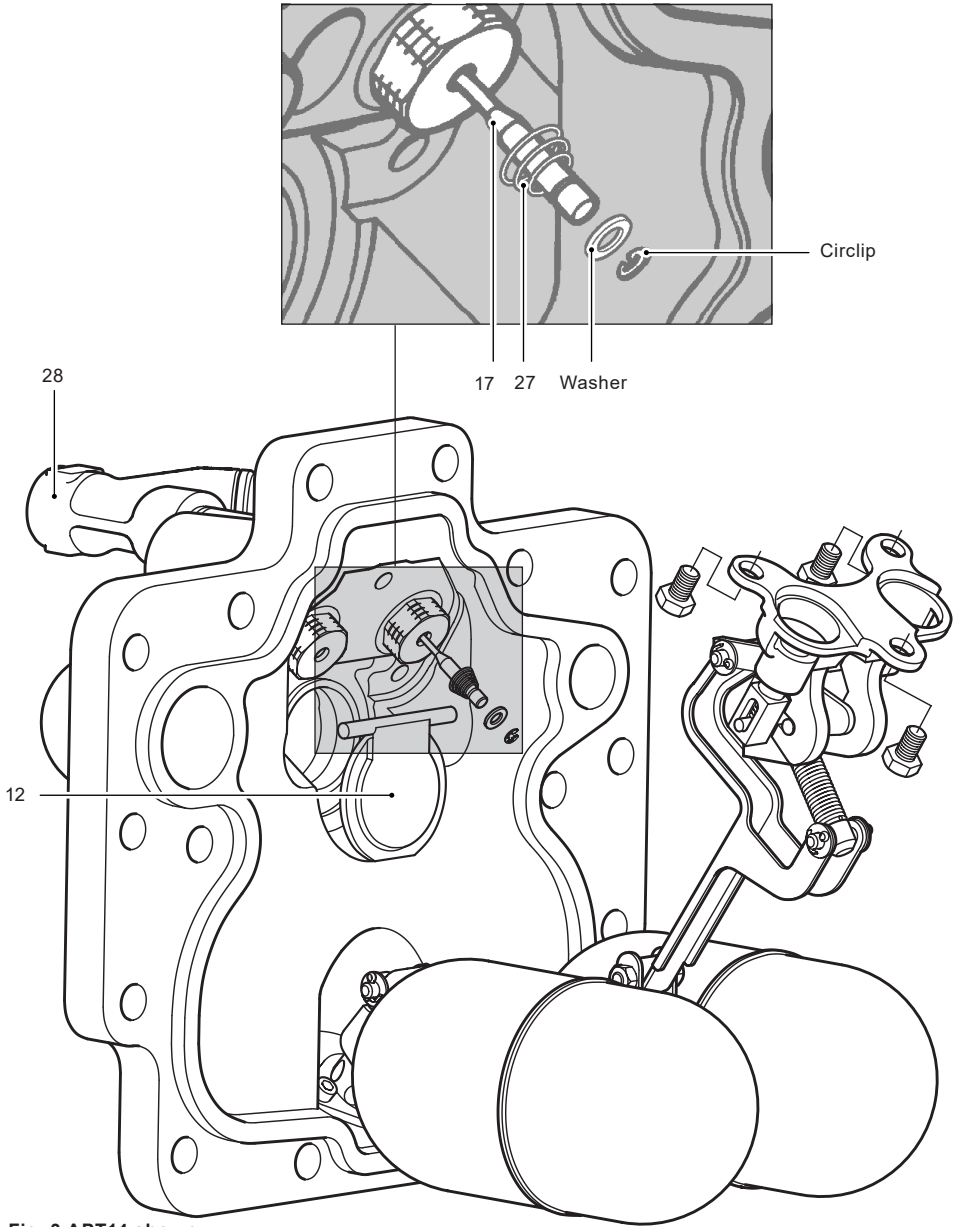

Fig. 3 APT14 shown

4. Replacement of spring and actuator arm

Please ensure the safety recommendations are observed before commencing with any maintenance of this product.

To replace the spring and actuator arm

1. Remove the cover and old gasket (see cover gasket replacement procedure, Section 2).
2. Lift the cover assembly to a bench or other convenient working surface and clamp securely, avoiding contact with the gasket face.
3. Ensure the floats are at the bottom of their travel.
4. Remove split pins, washers, and shafts (X and Y) from the top spring pivot and pump pivot points (See Figure 4).
5. Remove the spring and anchor assembly.
6. Draw the actuator arm with the exhaust valve downwards within its slots until it becomes free. It may be necessary to slide the exhaust valve (item 18) backwards against its internal spring to free it from the pump bracket guide (item 13), see Figure 5.
7. Remove the exhaust valve from the actuator arm (item 24, shown in Figure 4) being careful not to damage or lose the small exhaust valve compression spring.
8. The spring assembly and actuator arm can both be replaced.
9. **Fitting the new spring assembly and actuator arm is the opposite to removal.**

Remember to compress the small spring within the exhaust valve (item 18) before refitting to the spigot of the new actuator arm.

10. Ensure the actuator is correctly aligned and located within the slots of the pump bracket (item 13) (see Figure 5).
11. Once this is correctly located, ensure the exhaust valve can slide easily within its guides.
12. Always use new split pins and washers when refitting the spring retaining shaft (Y) and pump pivot shaft (X).
13. With the mechanism fully assembled, reposition the cover assembly with the body, ensuring the gasket faces are carefully aligned and no parts of the gasket are trapped or pinched outside the sealing areas. To ensure accurate alignment of the cover and body, it is recommended the lower part of the cover's gasket seal is located into the body first.

The top part of the seal can then be easily aligned.

14. Refit the cover bolts ensuring they are sequentially tightened in opposing pairs, gradually increasing torque to 63 ± 5 N m (46.5 ± 4 lbf ft).
15. Carefully reconnect the motive steam supply and the exhaust lines to the connections marked (S) and (E). The APT14, APT14HC or APT14SHC is now ready to recommission.
16. Make sure that the Spirax Sarco motive supply strainer (with 100 mesh screen) is reinstated to the motive supply connection (item 28, Figure 4).

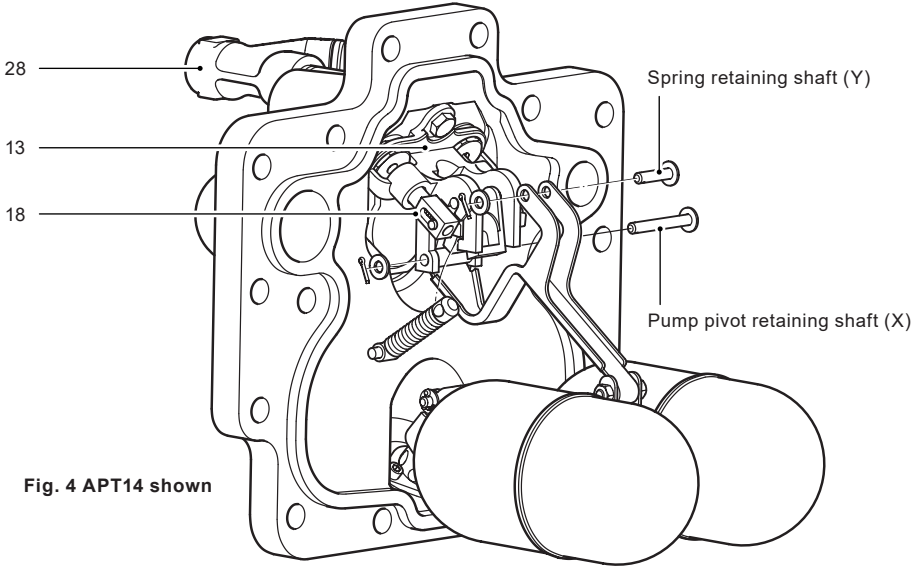

Fig. 4 APT14 shown

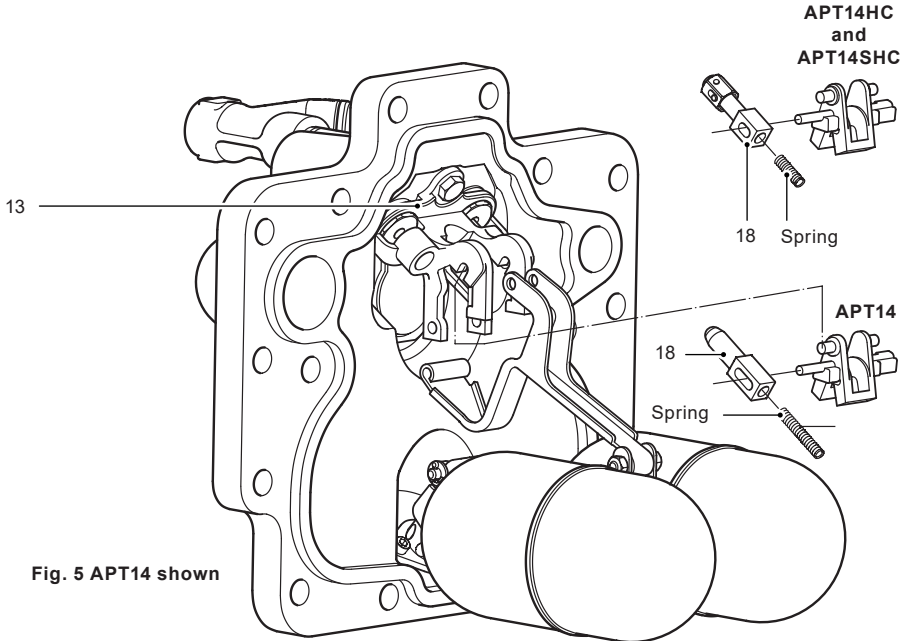

Fig. 5 APT14 shown

5. Replacement of floats

Please ensure the safety recommendations are observed before commencing with any maintenance of this product.

To replace the float and upper / lower levers

1. Remove the cover and old gasket (see cover gasket replacement procedure, Section 2).
2. Lift the cover assembly to a bench or other convenient working surface and clamp securely, avoiding contact with the gasket face.
3. Remove a split pin and washer from one side of the spring retaining shaft (Y) (See Figure 6).
4. Remove a split pin and washer from one side of pump pivot retaining shaft (X).
5. Carefully slide the shafts out from their respective positions observing the orientation of the spring and actuator arm (item 14, 24) within the pump bracket (item 13) as these will need to be refitted later.
6. Remove a split pin and washer from one side of the trap 1st stage valve retaining shaft (W).
7. Remove a split pin and washer from one side of the trap pivot retaining shaft (V).
8. The floats and lever assembly can now be removed and discarded as the replacement floats and levers are supplied fully assembled in the spares kit.
9. **Assembly is the opposite to removal.** Always fit new split pins and washers.
10. It is easier to fit the replacement shafts in the following sequence:- (See Figure 7).

V. Trap pivot	shaft length 38 mm for both APT14, APT14HC and APT14SHC
W. Trap 1st stage valve	shaft length 38 mm for both APT14, APT14HC and APT14SHC
X. Pump pivot	shaft length 52 mm for both APT14, APT14HC and APT14SHC
Y. Spring retainer	shaft length 30 mm for both APT14, APT14HC and APT14SHC

leaving the spring retaining shaft until after the spring and actuator arm have been correctly aligned and located within the slot of the pump bracket (item 13).

Ensure the spigot of the actuator arm is correctly engaged with the exhaust valve.

11. When all the shafts have been secured using new split pins and washers, move the floats to their upper and lower limits to ensure the mechanism operates smoothly and the spring and actuator arm snaps over to operate the motive steam inlet and exhaust valves (items 17, 18).

Note: The mechanism has been designed to be adjustment-free, simplifying the fitting of new parts. If after assembly the mechanism does not operate correctly, check all the parts are assembled and aligned as per the diagram.

12. With the mechanism fully assembled, refit the cover assembly to the body, ensuring the gasket faces are carefully aligned and no parts of the gasket are trapped or pinched outside the sealing areas. To ensure accurate alignment of the cover and body, it is recommended the lower part of the cover's gasket seal is located into the body first. The top part of the seal can then be easily aligned.
13. Refit the cover bolts ensuring they are sequentially tightened in opposing pairs, gradually increasing torque to $63 \pm 5 \text{ N m}$ ($46.5 \pm 4 \text{ lbf ft}$).
14. Carefully reconnect the motive steam supply and the exhaust lines to the connections marked (S) and (E). The APT14, APT14HC or APT14SHC is now ready for recommission.
15. Make sure that the Spirax Sarco motive supply strainer (with 100 mesh screen) is reinstated to the motive supply connection (item 28, Figure 6).

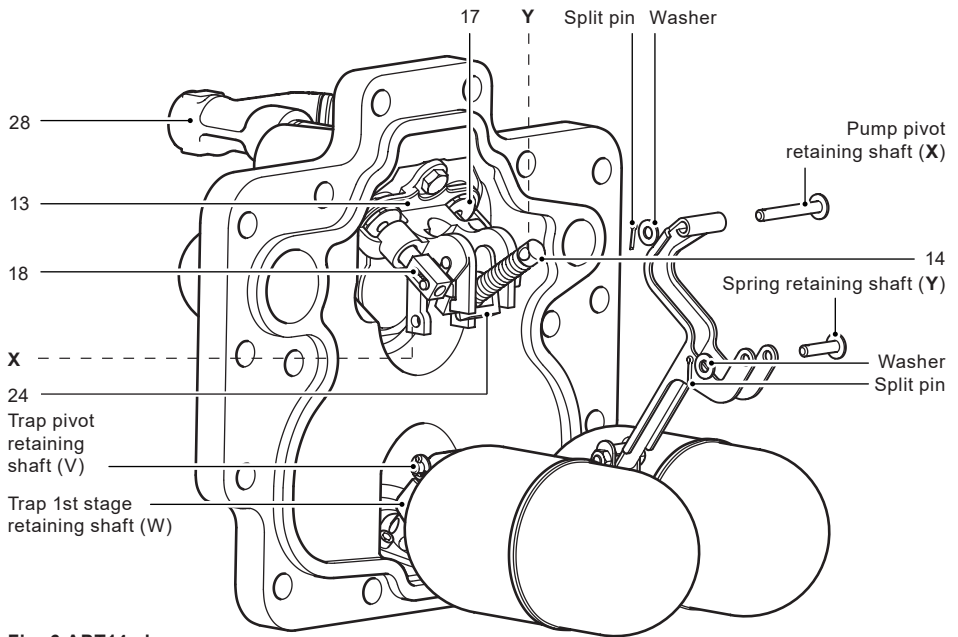

Fig. 6 APT14 shown

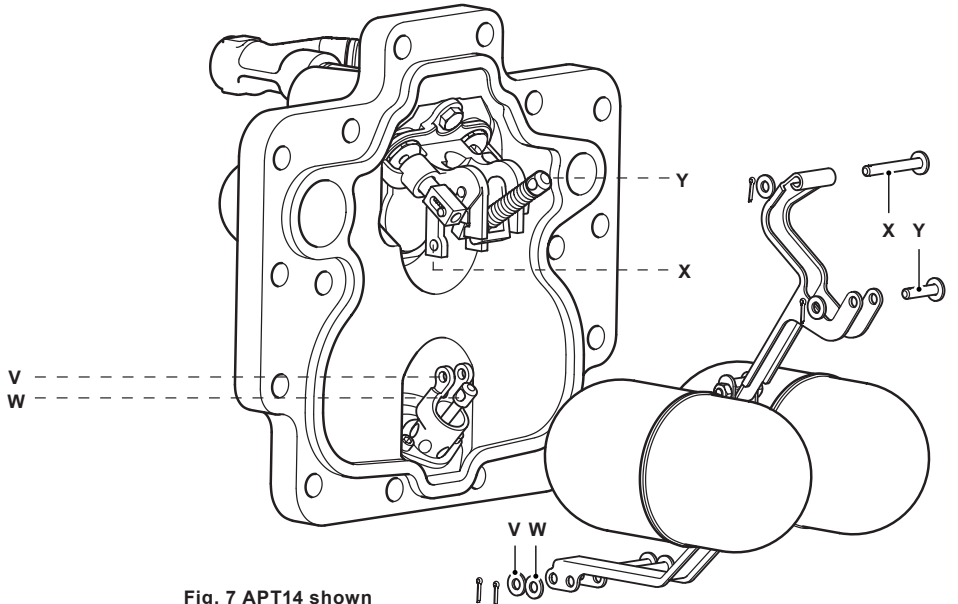

Fig. 7 APT14 shown

APT14, APT14HC and APT14SHC Spares 1

