

**APT10 -PPU, APT14 -PPU and APT14HC -PPU
(Closed System)**

Automatic Pump-trap Packaged Units

Installation and Maintenance Instructions

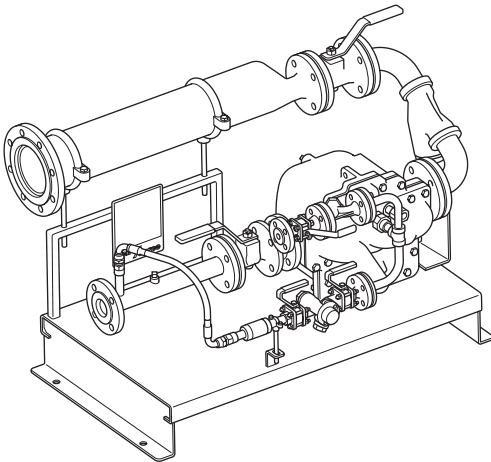

1. Safety information
2. General product information
3. Installation
4. Commissioning
5. Spare parts and Maintenance
6. Fault finding



1. Safety information

Safe operation of these products can only be guaranteed if they are properly installed, commissioned, used and maintained by qualified personnel (see Section 1.11) in compliance with the operating instructions. General installation and safety instructions for pipeline and plant construction, as well as the proper use of tools and safety equipment must also be complied with.

1.1 Intended use

Referring to the Installation and Maintenance Instructions, name-plate and Technical Information Sheet, check that the product is suitable for the intended use/application. The products listed below fully comply with the requirements of the European Pressure Equipment Directive 97/23/EC and carry the CE mark. The products fall within the following Pressure Equipment Directive categories:

Product	Group 1 Gases	Group 2 Gases	Group 1 Liquids	Group 2 Liquids
APT10-PPU	-	1	-	SEP
APT14-PPU	-	1	-	SEP
APT14HC-PPU	-	2	2	SEP

- i) The products have been designed for use on steam, air and water/condensate which are in Group 2 of the above mentioned Pressure Equipment Directive. The products' use on other fluids may be possible but, if this is contemplated, Spirax Sarco should be contacted to confirm the suitability of the product for the application being considered.
- ii) Check material suitability, pressure and temperature and their maximum and minimum values. If the maximum operating limits of the product are lower than those of the system in which it is being fitted, or if malfunction of the product could result in a dangerous overpressure or overtemperature occurrence, ensure a safety device is included in the system to prevent such over-limit situations.
- iii) Determine the correct installation situation and direction of fluid flow.
- iv) Spirax Sarco products are not intended to withstand external stresses that may be induced by any system to which they are fitted. It is the responsibility of the installer to consider these stresses and take adequate precautions to minimise them.
- v) Remove protection covers including cardboard support flanges from all connections and protective film from all name-plates, where appropriate, before installation on steam or other high temperature applications.

1.2 Access

Ensure safe access and if necessary a safe working platform (suitably guarded) before attempting to work on the product. Arrange suitable lifting gear if required.

1.3 Lighting

Ensure adequate lighting, particularly where detailed or intricate work is required.

1.4 Hazardous liquids or gases in the pipeline

Consider what is in the pipeline or what may have been in the pipeline at some previous time. Consider: flammable materials, substances hazardous to health, extremes of temperature.

1.5 Hazardous environment around the product

Consider: explosion risk areas, lack of oxygen (e.g. tanks, pits), dangerous gases, extremes of temperature, hot surfaces, fire hazard (e.g. during welding), excessive noise, moving machinery.

1.6 The system

Consider the effect on the complete system of the work proposed. Will any proposed action (e.g. closing isolation valves, electrical isolation) put any other part of the system or any personnel at risk?

Dangers might include isolation of vents or protective devices or the rendering ineffective of controls or alarms. Ensure isolation valves are turned on and off in a gradual way to avoid system shocks.

1.7 Pressure systems

Ensure that any pressure is isolated and safely vented to atmospheric pressure. Consider double isolation (double block and bleed) and the locking or labelling of closed valves. Do not assume that the system has depressurised even when the pressure gauge indicates zero.

1.8 Temperature

Allow time for temperature to normalise after isolation to avoid danger of burns.

1.9 Tools and consumables

Before starting work ensure that you have suitable tools and/or consumables available. Use only genuine Spirax Sarco replacement parts.

1.10 Protective clothing

Consider whether you and/or others in the vicinity require any protective clothing to protect against the hazards of, for example, chemicals, high/low temperature, radiation, noise, falling objects, and dangers to eyes and face.

1.11 Permits to work

All work must be carried out or be supervised by a suitably competent person. Installation and operating personnel should be trained in the correct use of the product according to the Installation and Maintenance Instructions.

Where a formal 'permit to work' system is in force it must be complied with. Where there is no such system, it is recommended that a responsible person should know what work is going on and, where necessary, arrange to have an assistant whose primary responsibility is safety.

Post 'warning notices' if necessary.

1.12 Handling

Manual handling of large and/or heavy products may present a risk of injury. Lifting, pushing, pulling, carrying or supporting a load by bodily force can cause injury particularly to the back. You are advised to assess the risks taking into account the task, the individual, the load and the working environment and use the appropriate handling method depending on the circumstances of the work being done.

1.13 Residual hazards

In normal use the external surface of the product may be very hot. If used at the maximum permitted operating conditions the surface temperature of these products may reach temperatures of 200°C (392°F).

These products are not self-draining. Take due care when dismantling or removing the product from an installation (refer to 'Maintenance instructions').

1.14 Freezing

Provision must be made to protect products which are not self-draining against frost damage in environments where they may be exposed to temperatures below freezing point.

1.15 Disposal

Unless otherwise stated in the Installation and Maintenance Instructions, this product is recyclable and no ecological hazard is anticipated with its disposal providing due care is taken.

1.16 Returning products

Customers and stockists are reminded that under EC Health, Safety and Environment Law, when returning products to Spirax Sarco they must provide information on any hazards and the precautions to be taken due to contamination residues or mechanical damage which may present a health, safety or environmental risk. This information must be provided in writing including Health and Safety data sheets relating to any substances identified as hazardous or potentially hazardous.

2. General product information

2.1 Description

The Spirax Sarco APT10-PPU, APT14-PPU and APT14HC-PPU automatic pump-trap packaged units are plug in systems specifically designed to remove condensate from plant under 'stall' conditions. The whole system is capable of handling capacities up to 2800 kg/h pumping and 9000 kg/h trapping, depending on available differential pressure.

Each unit comes with a condensate receiver, motive supply drain trap and ancillaries.

Operated by steam the APT10-PPU, APT14-PPU and APT14HC-PPU meet a wide range of applications. The standard pump-trap is manufactured from SG iron, although electroless nickel plated (ENP) versions are available on request.

Standards

These products fully comply with the requirements of the European Pressure Equipment Directive 97/23/EC and carry the **CE** mark. All welding is in accordance with ASME IX, BS EN 287/288, BS EN part 1-2004 and BS EN ISO 15614 part 1-2004.

Certification

These products are available with a Declaration of Conformity. If required, certification is available for individual component parts at extra cost. **Note:** All certification/inspection requirements must be stated at the time of order placement.

2.2 Sizes and pipe connections

Unit size		W Condensate inlet	X Motive supply	Y Exhaust/ balanced line	Z Condensate outlet
APT10-PPU	DN20 x DN20 (3/4" x 3/4")	PN16 DN65	DN15	DN15	DN20
APT14-PPU	DN40 x DN25 (1 1/2" x 1")	PN16 DN100	DN15	DN15	DN25
APT14HC-PPU	DN50 x DN40 (2" x 1 1/2")	PN16 DN125	DN15	DN15	DN40

2.3 Optional extra

A spool piece (Figure 1) is available as an optional extra to connect the receiver to the system pipework. The receiver flange is a standard size, dependent on the model of unit. The spool piece is available with four options of reduced pipe size to suit the application (three for the APT10-PPU).

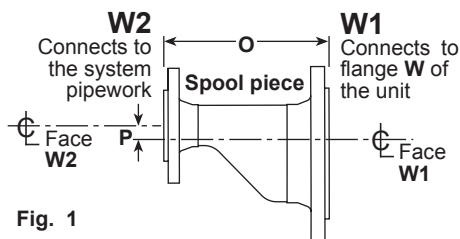

Fig. 1

Dimensions (approximate) in mm

Unit size	W1	W2	O	P
DN20 x DN20	DN65	DN25	173	20
		DN40	176	13
		DN50	180	7
DN40 x DN25	DN100	DN40	196	31
		DN50	201	26
		DN65	199	19
		DN80	204	12
DN50 x DN40	DN125	DN50	227	41
		DN65	227	33
		DN80	232	24
		DN100	234	13

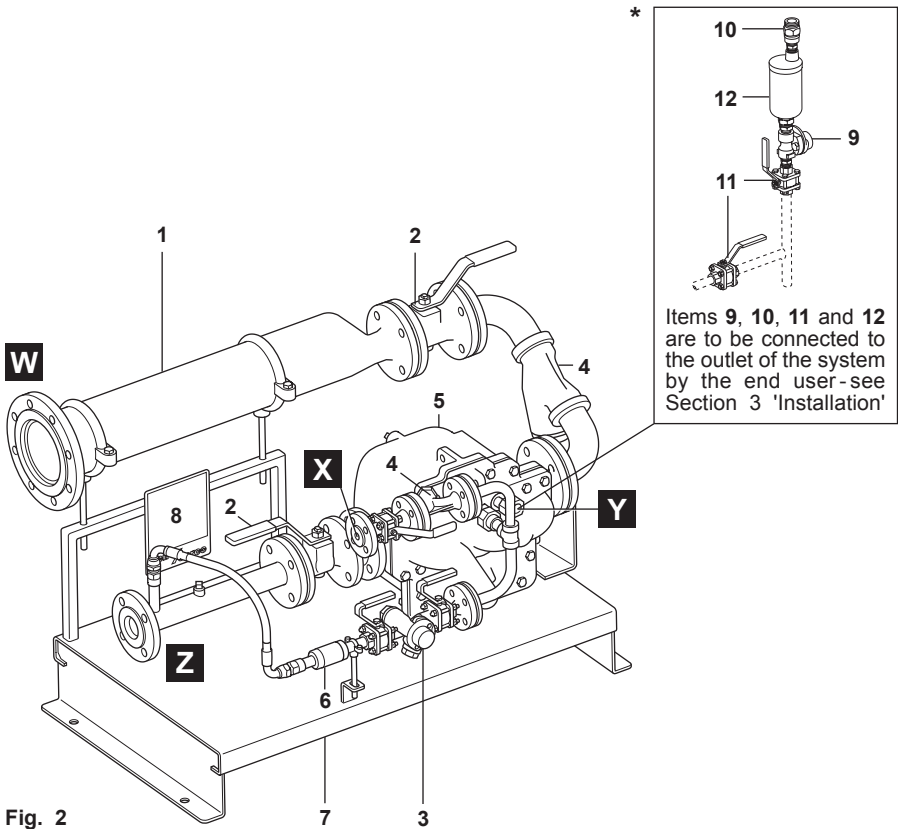

Fig. 2

2.4 Materials (Note: All flange gaskets are manufactured from semi rigid graphite)

No.	Part	Material
1	Receiver	Carbon steel
2	Ball valves DN20toDN50 (¼"to2")	Steel (PTFE seals)
3	Trap set DN15 (½")	Stainless steel (PTFE seals) STS17.2
4	Strainer DN15toDN50 (½"to2")	SG iron
5	Pump-trap	SG iron
6	Diffuser	Stainless steel
7	Base and supporting frame	Carbon steel
8	Name-plate	Aluminium
* 9	Air vent	Stainless steel PC10HP / UBP32
* 10	Check valve	Stainless steel
* 11	Ball valve DN15 (½")	Stainless steel
* 12	Air eliminator	Austenitic stainless steel AE50S

* **Please note:** Items 9, 10, 11 and 12 are not supplied with the package. They must be ordered as a separate item. It is intended that the end user provides the pipework and connects these components correctly - see Section 3 'Installation'.

2.5 Limiting conditions

Unit design conditions	APT10	PN10
	APT14 and APT14HC	PN16
Maximum motive inlet pressure (steam)	APT10	4.5 bar g
	APT14 and APT14HC	13.8 bar g
Maximum operating pressure	APT10	4.5 bar g
	APT14 and APT14HC	13.8 bar g
Maximum backpressure	APT10	4 bar g
	APT14 and APT14HC	5 bar g
Maximum operating temperature	APT10	155°C
	APT14 and APT14HC	198°C
Minimum operating temperature		0°C
Designed for a maximum cold hydraulic test pressure of:	APT10	15 bar g
	APT14 and APT14HC	24 bar g

Note: For operating temperatures above or below those stated contact Spirax Sarco.

2.6 Capacities

Sizing of the pump-trap is dependent on motive pressure, backpressure (lift, return system pressure and frictional losses) and process conditions. For accurate sizing for the application please contact Spirax Sarco.

3. Installation

Safety Notes:

Before actioning any installation, observe the 'Safety Information' in section 1.

3.1 Lifting

It is intended that the APT-PPU is moved by using a fork lift under the base plate to raise and finally place where required.

Under no circumstances should the unit be lifted by either the receiver or integral pipework.

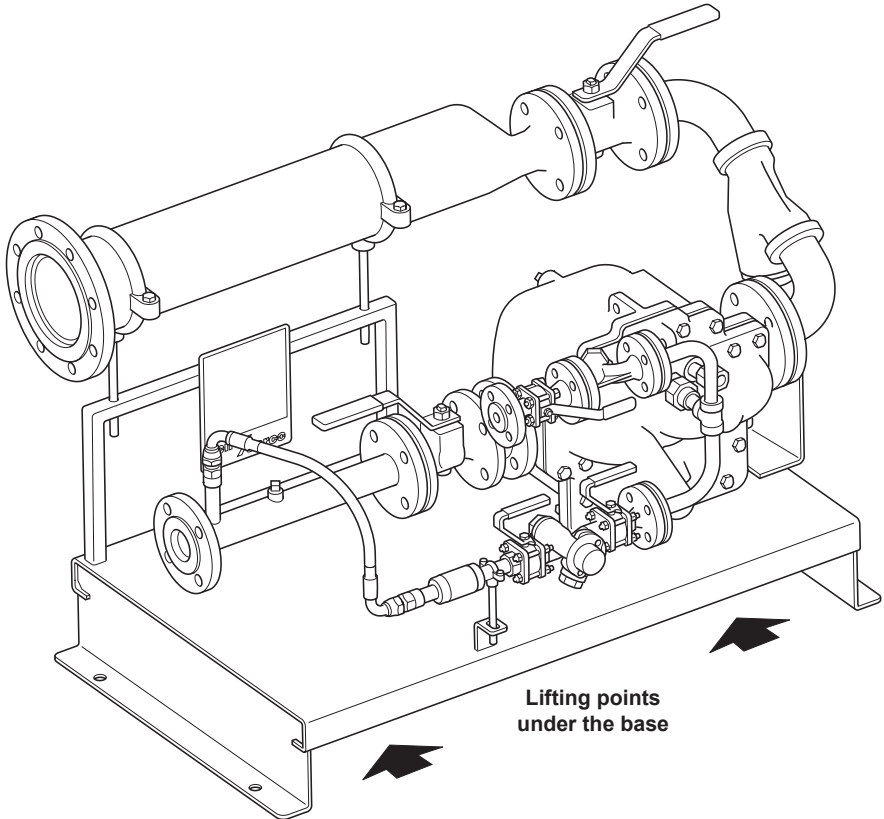

Fig. 3

3.2 Location

Thought should be given to the location of the unit for ease of maintenance, remembering that the cover/body of the pump-trap may need to be removed to gain access to the internals. **Note:** The APT10's body is removed from the back, leaving the cover and internal mechanism in position, whilst the APT14 and APT14HC is reversed, the cover and internal mechanism is removed from the front, leaving the body in position. For full details see product specific Installation and Maintenance Instruction.

For the trap unit to work correctly, condensate must be able to flow into the receiver under gravity. This normally necessitates it being installed below the condensate outlet of the plant being drained. Care should be taken to allow sufficient room for the unit to be levelled and secured by using the adjustable feet, and any additional supports (customer to supply).

3.3 Connections (refer to Figures 2 and 4)

The APT10, APT14 and APT14HC-PPU's are provided with four connections. They will only operate if each connection is piped to the correct service.

Connection W – is the condensate inlet connection. The APT10-PPU is provided with a DN65 (2½") PN16 flange. The APT14-PPU and APT14HC-PPU are provided with a DN100 (4") and DN125 (5") respectively.

Connection X – Is the steam motive supply connection. All units are provided with a DN15 (½") PN16 flange.

Connection Y – Is the pump exhaust/balance line connection. All units are provided with a DN15 (½") PN16 flange.

Connection Z – is the condensate outlet (discharge) connection. The APT10-PPU is provided with a DN20 (¾") PN16 flange. The APT14-PPU and APT14HC-PPU are provided with DN25 (1") and DN40 (1½") respectively.

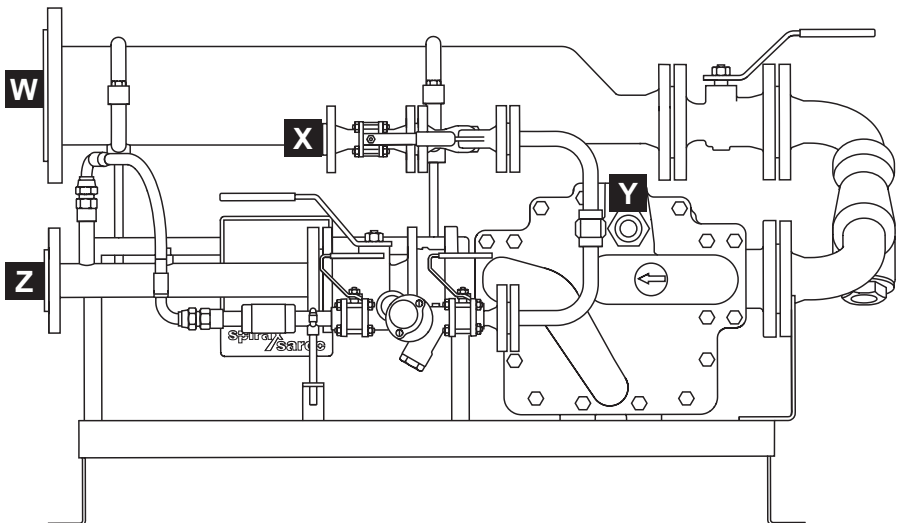

Fig. 4 Front elevation

3.4 Condensate inlet connection (W)

The condensate inlet connection incorporates an open-ended flange at one end of the overhead receiver, which is a standard size (see Figure 5). It may be necessary to reduce the connection in size to suit the line size of the of the plant outlet. To do so requires a spool piece (pipe reducer) which is available as an optional extra (see Section 2.3).

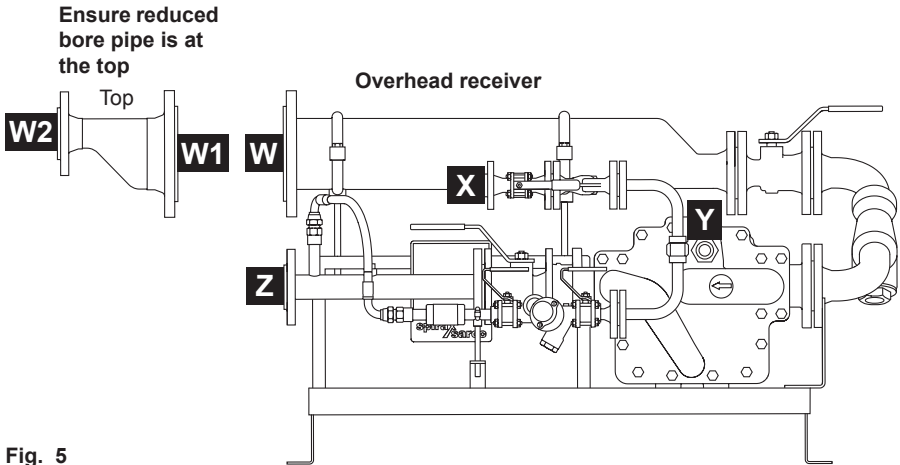

Fig. 5

3.5 Motive supply connection (X)

A steam motive supply is required to operate the pump-trap when under stall conditions. The units are provided with a motive supply drain trap and strainer, but it is recommended that the motive supply is conditioned before it is connected to the unit, to ensure that the unit only receives dry and clean saturated steam for optimum performance.

3.6 Pump exhaust/balance line connection (Y)

The exhaust/balance line serves two purposes. Firstly, to vent the motive steam and relieve the pressure in the pump-trap body, at the end of the pumping cycle. This allows the pump body to refill with fresh condensate. It is imperative that the balance line is fed back to the outlet of the process (see Figure 8). This completes the closed loop system, which allows the pump-trap to operate when the process is under vacuum conditions ('stall condition'). Secondly, a take-off from the balance line is required to install the air vent kit (supplied separately), check valve and ball valve. This allows any air and incondensable gases to be vented from the system. Care must be taken to ensure that the air vent is situated at a height above that of the inlet to the process (see Figure 8).

3.7 Condensate discharge connections (Z)

The condensate discharge connection should be piped back to either a central vented condensate return collection tank, or to the boiler feedtank. The discharge (return) pipe diameter should not be a reduced pipe size under any circumstances.

It is important for the discharge pipework to be correctly sized to prevent excessive backpressure. The pipework should be sized to take into account the effects of flash steam at the systems full load conditions and other equipment discharging into it. An allowance for frictional losses caused by pipe bends, elbows, isolation valves, check valves and other fittings should also be considered. It is recommended that ideally the discharge pipe should run independently to the condensate collection tank.

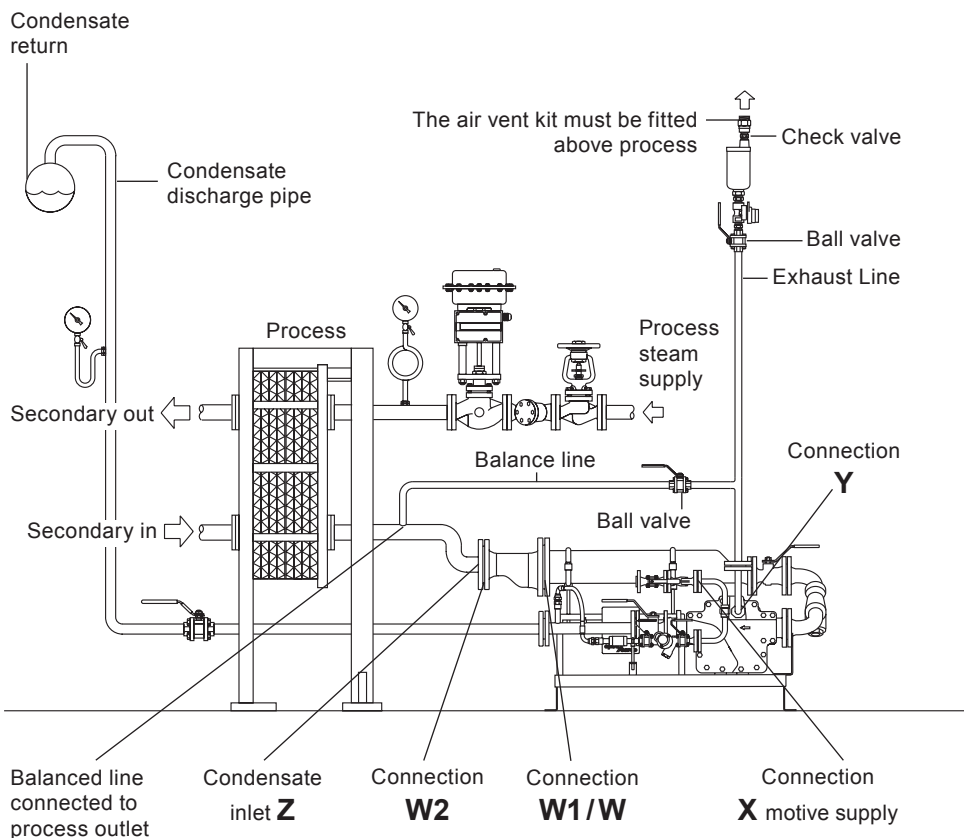

The exhaust and balance lines are to be supplied by others.

Fig. 6

3.8 Control of motive supply pressure

Although the APT-PPU's are able to utilise motive pressures up to 13.8 bar g (200 psi g) for the APT14-PPU and APT14HC-PPU and 4.5 bar g (65 psi g) for the APT10-PPU, it is recommended that the motive supply pressure does not exceed 2-4 bar g (29-58 psi g) above the backpressure applied to the pump.

When specifying a pressure reducing valve to reduce the motive supply pressure, the effects of pulsating flow must be considered. Contact Spirax Sarco for details of recommended installation if required.

3.9 Pressure gauges

It is highly recommended that pressure gauges are fitted to the motive supply, condensate outlet and inlet. A tapping on the pump body is also provided to fit a pressure gauge (refer to pump IMI).

4. Commissioning

- 4.1 After ensuring the inlet, exhaust, discharge, motive supply and exhaust lines are coupled in accordance with Figure 7, slowly open the motive supply inlet valve (Q) to supply pressure to the APT10 - PPU, APT14 - PPU and APT14 - PPU. Ensure that the exhaust/balance line is open (R) and not restricted in any way.
- 4.2 Slowly open the isolation valves in the condensate inlet (S) and discharge (T) lines, allowing the condensate to fill the body of the pump-trap.
- 4.3 Slowly open the motive supply drain trap isolation valves (U), to ensure the motive supply steam is kept dry.
- 4.4 The APT - PPU is now ready for operation.
- 4.5 The process steam supply line can now be slowly opened (V) to allow the process to start.
- 4.6 Check there are no leaks from any of the APT - PPU connections.
- 4.7 Check that the pressure gauges (customer supply) are not showing pressures above the maximum operating pressures of the APT - PPU.
- 4.8 Observe operation for any abnormalities, remembering that the APT - PPU will only pump when there is insufficient differential to remove the condensate from the process. At all other times the APT - PPU should be in the trapping mode and may set at a constant discharge rate. If any irregularities are observed, recheck that the installation is as recommended in Section 3, then consult the Fault finding guide in Section 6.

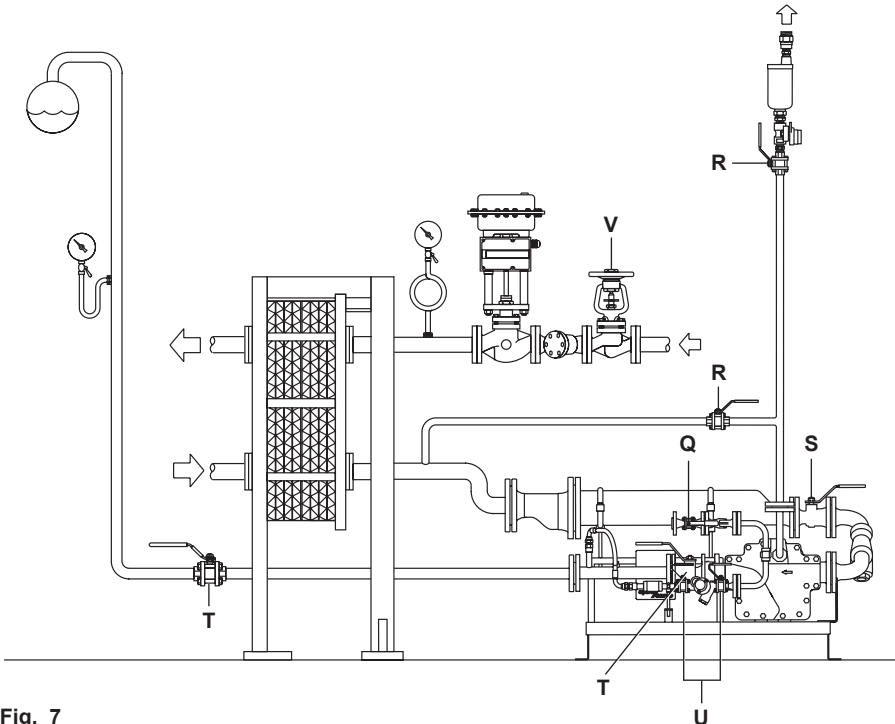

Fig. 7

— 5. Spare parts and maintenance —

5.1 Spare parts

The main component products such as the APT, isolating valves and strainers etc; are available as complete separate products. Individual spares for these are also available if required. See product specific Technical Information sheets (TI) or Installation and Maintenance Instructions (IM) for complete spares listing.

Pipework sub-assemblies can also be supplied by special order, contact Spirax Sarco for details.

Note: Flange gaskets, jointing paste / tape and flange nuts and bolts are not available as spares.

5.2 Maintenance:

- Before any installation or maintenance procedure, always ensure that all steam or condensate lines are isolated. Ensure any residual internal pressure in the product or connecting lines is carefully relieved. Also ensure any hot parts have cooled to prevent risk of injury from burns. Always wear appropriate safety clothing before carrying out any installation or maintenance work.
- Before commencing any maintenance ensure, all relevant permits to work have been obtained and completed.
- Spare parts for component products are available. For full details and fitting/maintenance instructions see separate relevant Installation and Maintenance Instructions (IM).
- If the unit is to be removed from the installation, ensure the lifting instructions are followed, detailed in Section 1 and Section 3.1.

6. Fault finding guide

Caution

Installation and trouble shooting should only be performed by qualified personnel. Before any maintenance is attempted, ensure any residual internal pressure in the product or connecting lines is carefully relieved. Also ensure any hot parts have cooled to prevent risk of injury from burns. Always wear appropriate safety clothing before carrying out any installation or maintenance work.

The APT10-PPU, APT14-PPU and APT14HC-PPU are thoroughly tested before leaving the factory. This includes a comprehensive functional test. If the unit has failed to operate it is likely that an installation problem could exist. Please check the following before commencing with the trouble-shooting chart.

6.1 Trouble areas to check first

- Are all isolating valves open?
- Is the condensate inlet strainer clean and free from debris?
- Is the motive supply strainer clean and free of debris?
- Is the available motive pressure higher than the total backpressure? (recommended 2 to 4 bar g (44 to 58 psi g) but not exceeding 13.8 bar g (200 psi g) for the APT14 and APT14HC and 4.5 bar g (65 psi g) for the APT10.
- Is the exhaust balance line connected to the outlet of the equipment being drained and is it free from obstruction (refer to the installation diagram Figure 9, page 13)?
- Is the direction of flow through the unit correct, indicated by the flow arrow?

6.2 Quick reference trouble-shooting guide

SYMPTOM	APT-PPU fails to operate on start-up.
CAUSE 1	No motive pressure.
CHECK and CURE	Motive supply pressure exceeds total backpressure.
CAUSE 2	Inlet isolation valve maybe closed.
CHECK and CURE	Inlet pipe is free from obstructions and the isolation valve is open.
CAUSE 3	Motive inlet and exhaust lines incorrectly connected.
CHECK and CURE	Motive = X, Exhaust = Y.
CAUSE 4	The rate of condensate produced by the process maybe very low, causing the APT-PPU to cycle slowly.
CHECK and CURE	The process being drained is operating correctly.
SYMPTOM	Equipment flooded - but APT appears to cycle normally.
CAUSE 1	APT-PPU is undersized for the application.
CHECK and CURE	Check system parameters agree with the custom sizing sheet / graph.
SYMPTOM	Equipment flooded and APT-PPU has stopped cycling.
CAUSE 1	Blocked exhaust line.
CHECK and CURE	Balance line is free from obstruction or isolated.
CAUSE 2	Blocked condensate inlet line.
CHECK and CURE	Firstly check that the inlet line is not isolated. Secondly check and clean the strainer mesh for blockages.
CAUSE 3	Blocked condensate outlet line.
CHECK and CURE	Firstly check that the outlet line is not isolated. Secondly check and clean the strainer mesh for blockages.

6.2 Quick reference trouble-shooting guide (continued)

CAUSE 4	Damaged mechanism.
CHECK and CURE	See separate Installation and Maintenance Instructions (IM) for the pump-trap
CAUSE 5	No motive steam available.
CHECK and CURE	Steam supply to APT-PPU is available and at the correct pressure. Motive pressure must exceed total backpressure. Ensure motive supply strainer is clear of debris. Clean or replace if necessary.
CAUSE 6	Leaking motive inlet valve.
CHECK and CURE	If the APT-PPU body is hot (observe safety information in Section 1), this indicates the APT's mechanism is stuck on the discharge cycle. Check mechanism for excessive friction as per Section 6. See separate Installation and Maintenance Instructions (IM) for the pump-trap.
CAUSE 7	Broken spring.
CHECK and CURE	If the APT-PPU body is cold, this indicates the APT's mechanism is stuck on the filling cycle. See separate Installation and Maintenance Instructions (IM) for the pump-trap.
CAUSE 8	Blocked condensate inlet line.
CHECK and CURE	Inspect and clean the filter, check for blockages.
SYMPTOM	Chattering or banging of the APT-PPU during cold start-up.
CAUSE 1	Hydraulic pulsing of the inlet check valve.
CHECK and CURE	Reduce installation head to APT-PPU - throttle valve on APT-PPU condensate inlet.
SYMPTOM	Chattering or banging in the return line after APT-PPU discharges.
CAUSE 1	Live steam entering discharge line.
CHECK and CURE	Ensure that the steam trap draining the motive supply line is working correctly.
CAUSE 2	Motive pressure too high.
CHECK and CURE	For optimum capacity and performance, the motive pressure should not exceed 2-4 bar g (29-58 psi g) above the total backpressure (differential pressure). Reduce the motive pressure using a suitable pressure reducing valve, taking into account the effects of cyclic flow.
