

**APT10-4.5**

**Spares 1**

**Installation and Maintenance Instructions**

---

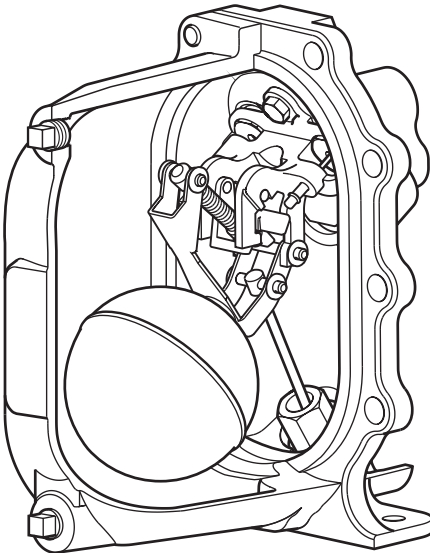

1. *General safety information*
2. *Replacement of cover gasket*
3. *Replacement of inlet swing check valve*
4. *Replacement of spring and actuator arm*
5. *Replacement of float*



# 1. *General safety information*

Safe operation of these units can only be guaranteed if they are properly installed, commissioned and maintained by a qualified person in compliance with the operating instructions. All work must be carried out or be supervised by a suitably competent person. Installation and operating personnel should be trained in the correct use of the product according to the Installation and Maintenance Instructions.

Where a formal 'permit to work' system is in force it must be complied with. Where there is no such system, it is recommended that a responsible person should know what work is going on and, where necessary, arrange to have an assistant whose primary responsibility is safety.

Post 'warning notices' if necessary.

General installation and safety instructions for pipeline and plant construction, as well as the proper use of tools and safety equipment must also be complied with.

## **Isolation**

Consider whether closing isolating valves will put any other part of the system or personnel at risk. Dangers might include: isolation of vents, protective devices or alarms. Ensure isolation valves are turned off in a gradual way to avoid system shocks.

## **Pressure**

Before attempting any maintenance consider what is or may have been in the pipeline. Ensure that any pressure is isolated and safety vented to atmospheric pressure before attempting to maintain the product, this is easily achieved by fitting Spirax Sarco depressurisation valves type DV (see separate literature for details). Do not assume that the system is depressurised even when a pressure gauge indicates zero.

## **Temperature**

Allow time for temperature to normalise after isolation to avoid the danger of burns and consider whether protective clothing (including safety glasses) is required.

## **Disposal**

These products are recyclable. No ecological hazard is anticipated with the disposal of these products providing due care is taken.

---

## 2. Replacement of cover gasket

---

Please ensure the safety recommendations are observed before commencing with any maintenance of this product.

### Tools required

19 mm A/F socket, Flat blade screw driver, Torque wrench

### To fit the new cover gasket

1. Disconnect all connections to the cover. Remove the cover bolts using a 19 mm A/F socket, then carefully slide the cover assembly away from the body (225 mm minimum withdrawal distance will be needed). Lift the cover assembly to a bench or other convenient working surface and clamp securely, avoiding contact with the gasket face (See Fig. 1).
2. Gently remove used gasket material from the body and cover, being careful not to damage the gasket sealing faces.
3. Carefully fit a new gasket (item 2) into the existing body (See Fig. 2).
4. **Refit the cover assembly to the body**, ensuring the gasket faces are carefully aligned and no parts of the gasket are trapped or pinched outside the sealing areas.
5. Refit the cover bolts ensuring they are sequentially tightened in opposing pairs, gradually increasing torque to  $63 \pm 5$  N m.

<b>Bolt size</b>	<b>Socket size</b>	<b>Tightening torque</b>
M12 x 40	19 mm A/F	$63 \pm 5$ N m

6. Carefully reconnect the motive steam supply and the exhaust lines to the connections marked (S) and (E), and the condensate inlet and outlet to the connections marked (IN) and (OUT). The APT10-4.5 is now ready to recommission.

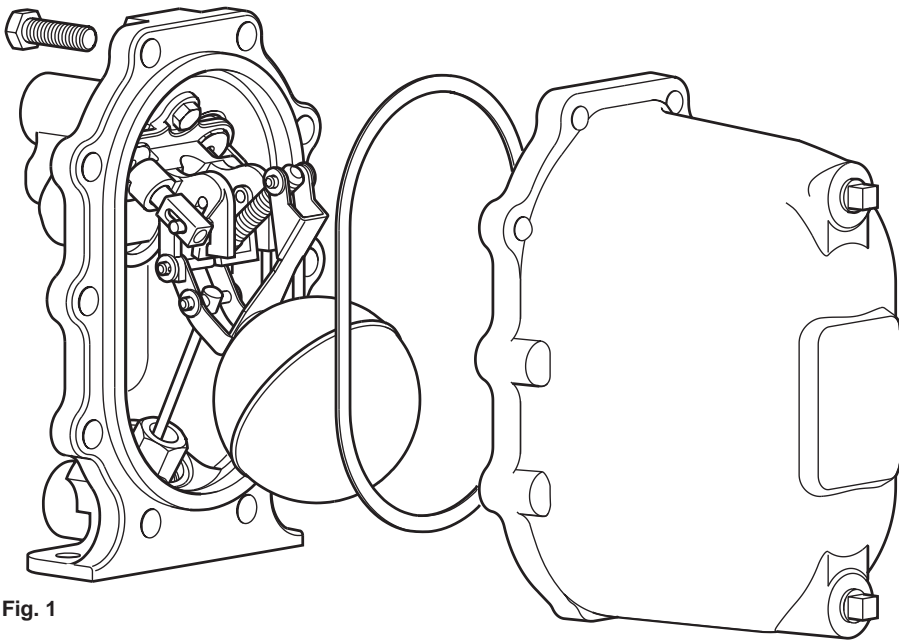

Fig. 1

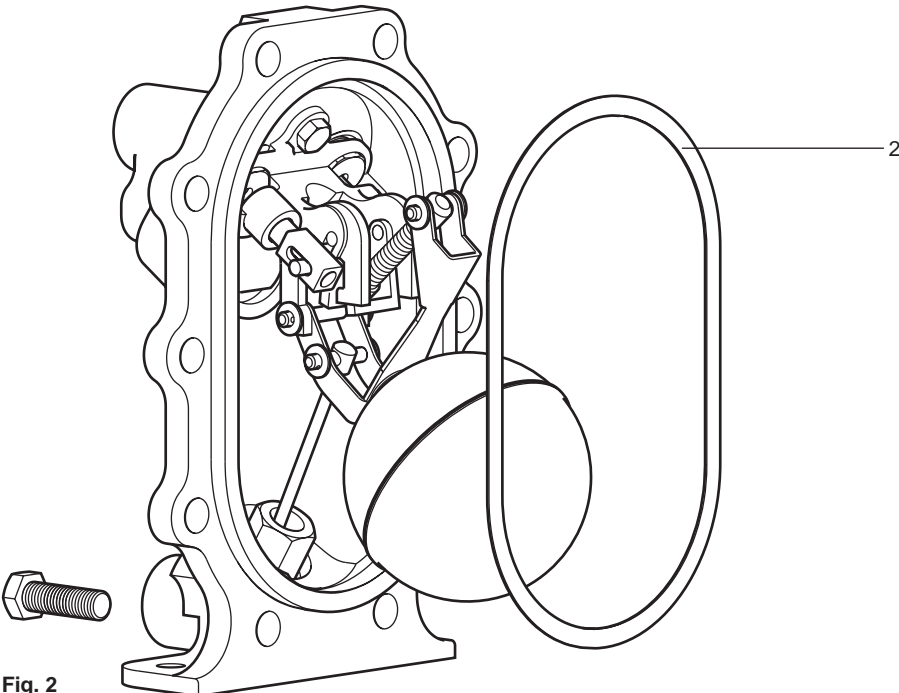

Fig. 2

---

## 3. Replacement of inlet swing check valve

---

Please ensure the safety recommendations are observed before commencing with any maintenance of this product.

### Tools required

19 mm A/F socket, 13 mm A/F socket, Flat blade screw driver, Torque wrench, Long nose pliers

### To replace the inlet swing check valve

1. Remove the cover and old gasket (see cover gasket replacement procedure, Section 2).
2. Lift the cover assembly to a bench or other convenient working surface and clamp securely, avoiding contact with the gasket face.
3. Carefully remove the circlip from the end of the steam inlet valve (item 17).
4. Remove the three M8 bolts that secure the pump mechanism bracket using the 13 mm A/F socket.
5. Lift away the pump bracket assembly (See Fig. 3). This will allow access to the inlet swing check valve (item 12).

**Note: Do not allow the spring in the pump mechanism to bend back on itself as this may damage the coils and shorten the life of the spring.**

6. The swing check valve flap can now easily be withdrawn.
7. Fit a new flap, ensuring the face of the check valve flap and seat are clean and free from damage.
8. **Reassembly is the opposite to removal.**
9. Tighten the three M8 bolts using the 13 mm A/F socket to  $18 \pm 2$  N m.
10. It is important to ensure a new circlip is refitted to the steam inlet valve.
11. With the mechanism fully assembled, refit the cover assembly to the body, ensuring the gasket faces are carefully aligned and no parts of the gasket are trapped or pinched outside the sealing areas.
12. Refit the cover bolts ensuring they are sequentially tightened in opposing pairs, gradually increasing torque to  $63 \pm 5$  N m.
13. Carefully reconnect the motive steam supply and the exhaust lines to the connections marked (S) and (E), and the condensate inlet and outlet to the connections marked (IN) and (OUT). The APT10-4.5 is now ready to recommission.

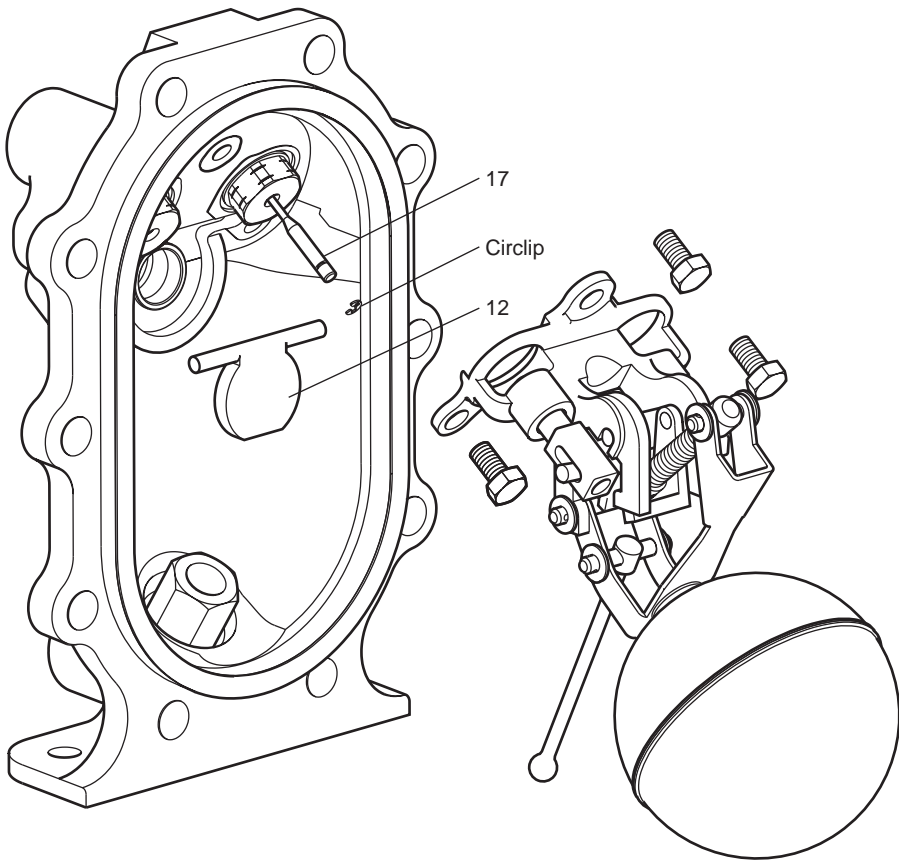

Fig. 3

---

## 4. Replacement of spring and actuator arm

---

Please ensure the safety recommendations are observed before commencing with any maintenance of this product.

### Tools required

19 mm A/F socket, Flat blade screw driver, Torque wrench, Long nose pliers

### To replace the spring and actuator arm

1. Remove the cover and old gasket (see cover gasket replacement procedure, Section 2).
2. Lift the cover assembly to a bench or other convenient working surface and clamp securely, avoiding contact with the gasket face.
3. Ensure the float is at the bottom of its travel.
4. Remove the split pin and washer, from the spring retaining shaft (Y). (See Fig. 4).
5. Remove the shaft and allow the spring to drop free.
6. Draw the actuator arm downwards within its slots until the whole spring and actuator arm assembly with the exhaust valve comes free. It may be necessary to slide the exhaust valve (item 18) backwards against its internal spring to free it from the pump bracket guide (item 13).
7. Align the slot in the exhaust valve with the tang of the actuator arm.
8. Gently rotate the exhaust valve away from the tanged spigot of the actuator arm (item 24, shown in Fig. 4) being careful not to damage or lose the small exhaust valve compression spring.
9. The spring and actuator arm can both be replaced.  
**Note:** There is no need to remove the spring from the actuator arm, as both these items are supplied fully assembled in the spares kit (See Fig. 5).
10. **Fitting the new spring and actuator arm is the opposite to removal.** Remember to compress the small spring within the exhaust valve (item 18) before refitting to the tanged spigot of the new actuator arm.
11. Ensure the actuator is correctly aligned and located within the slots of the pump bracket (item 13).
12. Once this is correctly located, ensure the exhaust valve can slide easily within its guides.
13. Always use new split pins and washers when refitting the spring retaining shaft (Y).
14. With the mechanism fully assembled, reposition the cover assembly with the body, ensuring the gasket faces are carefully aligned and no parts of the gasket are trapped or pinched outside the sealing areas.
15. Refit the cover bolts ensuring they are sequentially tightened in opposing pairs, gradually increasing torque to  $63 \pm 5$  N m.
16. Carefully reconnect the motive steam supply and the exhaust lines to the connections marked (S) and (E) and the condensate inlet and outlet to the connections marked (IN) and (OUT). The APT10-4.5 is now ready to recommission.



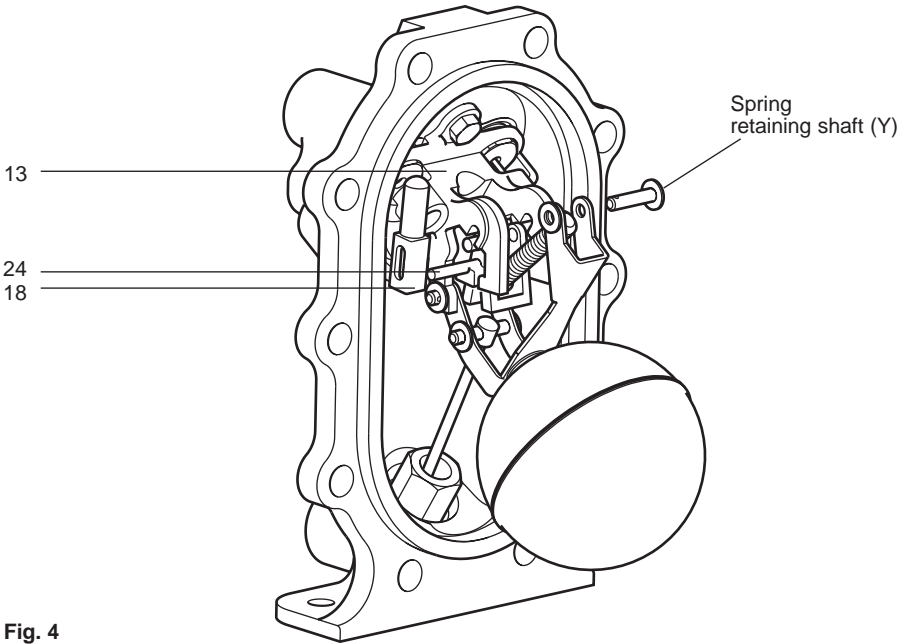

Fig. 4

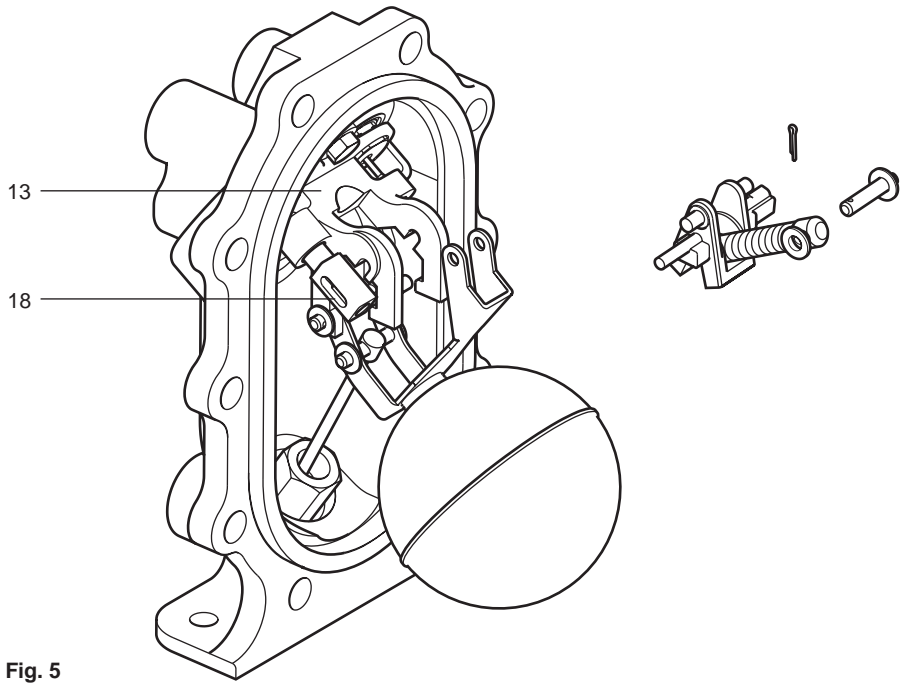

Fig. 5

---

## 5. Replacement of float

---

Please ensure the safety recommendations are observed before commencing with any maintenance of this product.

### Tools required

19 mm A/F socket, 13 mm A/F socket, Flat blade screw driver, Torque wrench, Long nose pliers

### To replace the float and lever

1. Remove the cover and old gasket (see cover gasket replacement procedure, Section 2).
2. Lift the cover assembly to a bench or other convenient working surface and clamp securely, avoiding contact with the gasket face.
3. Remove the split pin and washer from one side of the spring retaining shaft (Y) and carefully remove. (See Fig. 6).  
**Note: It is extremely important this is done first to prevent over stressing the spring during Step 4.**
4. Remove the split pin and washer from one side of trap pivot retaining shaft (Z) and carefully remove.
5. Carefully slide the shafts out from their respective positions observing the orientation of the spring and actuator arm (item 14, 24) within the pump bracket (item 13) as these will need to be refitted later.
6. Remove the split pin and washer from one side of pump pivot retaining shaft (X).
7. To remove shaft (X), the whole pump bracket (13) will need to be separated from the cover. This can be done by unscrewing the three M8 retaining bolts, and **removing the circlip from the steam inlet valve** (17). Remove the pump pivot retaining shaft (X).
8. The float and lever assembly can now be removed and discarded as the replacement float and lever is supplied fully assembled in the spares kit.
9. **Assembly is the opposite to removal.** Always fit new split pins and washers.
10. It is easier to fit the replacement shafts in the following sequence:- (See Fig. 7).  
**X. Pump pivot** (shaft length 52 mm)  
**Refit pump bracket (13) to cover and tighten the three M8 bolts using the 13 mm A/F socket to  $18 \pm 2$  N m. Refit the new circlip to the steam inlet valve.**  
**Z. Trap pivot** (shaft length 40 mm)  
**Y. Spring retainer** (shaft length 30 mm)  
leaving the spring retaining shaft until after the spring and actuator arm have been correctly aligned and located within the slot of the pump bracket (item 13).  
Ensure the tanged spigot of the actuator arm is correctly engaged with the exhaust valve.
11. When all the shafts have been secured using new split pins and washers, move the float to its upper and lower limit to ensure the mechanism operates smoothly and the spring and actuator arm snaps over to operate the motive steam inlet and exhaust valves (items 17, 18).  
**Note:** The mechanism has been designed to be adjustment-free, simplifying the fitting of new parts. If after assembly the mechanism does not operate correctly, check all the parts are assembled and aligned as per the diagram.
12. With the mechanism fully assembled, refit the cover assembly to the body, ensuring the gasket faces are carefully aligned and no parts of the gasket are trapped or pinched outside the sealing areas.

13. Refit the cover bolts ensuring they are sequentially tightened in opposing pairs, gradually increasing torque to  $63 \pm 5 \text{ N m}$ .

14. Carefully reconnect the motive steam supply and the exhaust lines to the connections marked (S) and (E) and the condensate inlet and outlet to the connections marked (IN) and (OUT). The APT10-4.5 is now ready to recommission.

Fig. 6

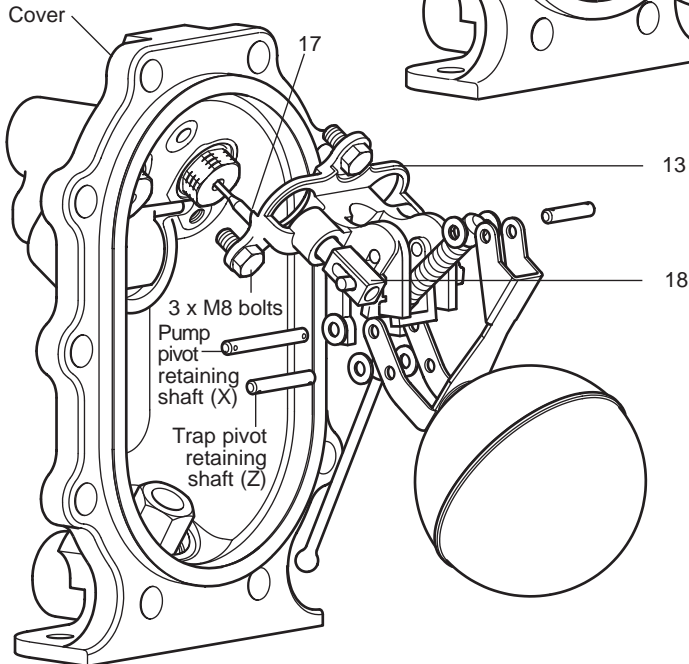
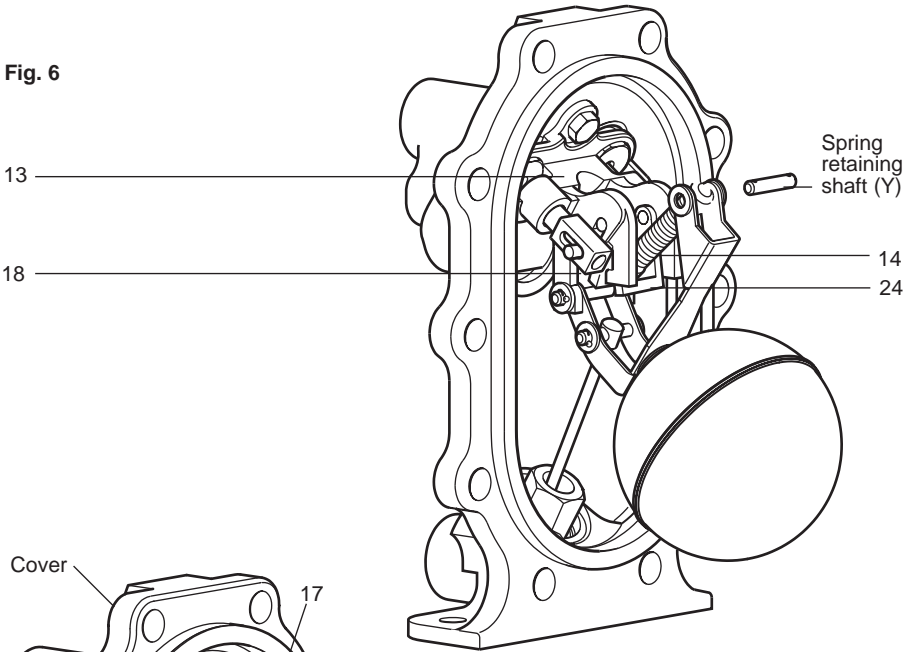

Fig. 7

