

**AE30**

**Automatic Air Eliminators / Air and Gas Vents  
for Liquid Systems  
Installation and Maintenance Instructions**

---

---

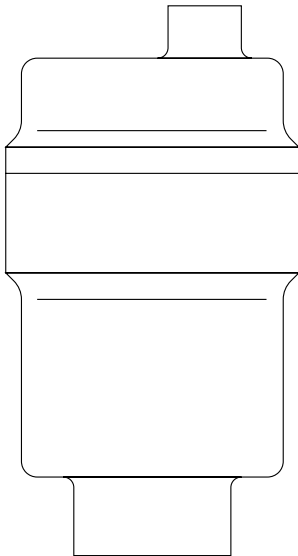

- 1. Safety information*
- 2. General product information*
- 3. Installation*
- 4. Commissioning*
- 5. Operation*
- 6. Maintenance*
- 7. Spare parts*

# 1. Safety information

Safe operation of these products can only be guaranteed if they are properly installed, commissioned, used and maintained by qualified personnel (see Section 1.11) in compliance with the operating instructions. General installation and safety instructions for pipeline and plant construction, as well as the proper use of tools and safety equipment must also be complied with.

## 1.1 Intended use

Referring to the Installation and Maintenance Instructions, name-plate and Technical Information Sheet, check that the product is suitable for the intended use/application. The products listed below comply with the requirements of the European Pressure Equipment Directive 97/23/EC and carry the  $\text{CE}$  mark when so required. It should be noted that products rated as 'SEP' are required by the Directive not to carry the  $\text{CE}$  mark. The products fall within the following Pressure Equipment Directive categories:

Product	Group 1 Gases	Group 2 Gases	Group 1 Liquids	Group 2 Liquids
AE30 (all versions)	-	SEP	-	SEP

- i) The product has been specifically designed for use on steam, air or water/condensate which are in Group 2 of the above mentioned Pressure Equipment Directive. The products' use on other fluids may be possible but, if this is contemplated, Spirax Sarco should be contacted to confirm the suitability of the product for the application being considered.
- ii) Check material suitability, pressure and temperature and their maximum and minimum values. If the maximum operating limits of the product are lower than those of the system in which it is being fitted, or if malfunction of the product could result in a dangerous overpressure or overtemperature occurrence, ensure a safety device is included in the system to prevent such over-limit situations.
- iii) Determine the correct installation situation and direction of fluid flow.
- iv) Spirax Sarco products are not intended to withstand external stresses that may be induced by any system to which they are fitted. It is the responsibility of the installer to consider these stresses and take adequate precautions to minimise them.
- v) Remove protection covers from all connections and protective film from all name-plates, where appropriate, before installation on steam or other high temperature applications.

## 1.2 Access

Ensure safe access and if necessary a safe working platform (suitably guarded) before attempting to work on the product. Arrange suitable lifting gear if required.

## 1.3 Lighting

Ensure adequate lighting, particularly where detailed or intricate work is required.

---

## 1.4 Hazardous liquids or gases in the pipeline

Consider what is in the pipeline or what may have been in the pipeline at some previous time. Consider: flammable materials, substances hazardous to health, extremes of temperature.

## 1.5 Hazardous environment around the product

Consider: explosion risk areas, lack of oxygen (e.g. tanks, pits), dangerous gases, extremes of temperature, hot surfaces, fire hazard (e.g. during welding), excessive noise, moving machinery.

## 1.6 The system

Consider the effect on the complete system of the work proposed. Will any proposed action (e.g. closing isolation valves, electrical isolation) put any other part of the system or any personnel at risk?

Dangers might include isolation of vents or protective devices or the rendering ineffective of controls or alarms. Ensure isolation valves are turned on and off in a gradual way to avoid system shocks.

## 1.7 Pressure systems

Ensure that any pressure is isolated and safely vented to atmospheric pressure. Consider double isolation (double block and bleed) and the locking or labelling of closed valves. Do not assume that the system has depressurised even when the pressure gauge indicates zero.

## 1.8 Temperature

Allow time for temperature to normalise after isolation to avoid the danger of burns.

If parts made from Viton have been subjected to a temperature approaching 315°C (599°F) or higher, it may have decomposed and formed hydrofluoric acid. Avoid skin contact and inhalation of any fumes as the acid will cause deep skin burns and damage the respiratory system.

If parts made from PTFE have been subjected to a temperature approaching 260°C (500°) or higher, they will give off toxic fumes, which if inhaled are likely to cause temporary discomfort. It is essential for a no smoking rule to be enforced in all areas where PTFE is stored, handled, or processed as persons inhaling the fumes from burning tobacco contaminated with PTFE particles can develop 'polymer fume fever'.

## 1.9 Tools and consumables

Before starting work ensure that you have suitable tools and/or consumables available. Use only genuine Spirax Sarco replacement parts.

## 1.10 Protective clothing

Consider whether you and/or others in the vicinity require any protective clothing to protect against the hazards of, for example, chemicals, high/low temperature, radiation, noise, falling objects, and dangers to eyes and face.

---

## 1.11 Permits to work

All work must be carried out or be supervised by a suitably competent person. Installation and operating personnel should be trained in the correct use of the product according to the Installation and Maintenance Instructions.

Where a formal 'permit to work' system is in force it must be complied with. Where there is no such system, it is recommended that a responsible person should know what work is going on and, where necessary, arrange to have an assistant whose primary responsibility is safety.

Post 'warning notices' if necessary.

## 1.12 Handling

Manual handling of large and/or heavy products may present a risk of injury. Lifting, pushing, pulling, carrying or supporting a load by bodily force can cause injury particularly to the back. You are advised to assess the risks taking into account the task, the individual, the load and the working environment and use the appropriate handling method depending on the circumstances of the work being done.

## 1.13 Residual hazards

In normal use the external surface of the product may be very hot. If used at the maximum permitted operating conditions the surface temperature of some products may reach temperatures of 100°C (212°F).

Many products are not self-draining. Take due care when dismantling or removing the product from an installation (refer to 'Maintenance instructions').

## 1.14 Freezing

Provision must be made to protect products which are not self-draining against frost damage in environments where they may be exposed to temperatures below freezing point.

## 1.15 Disposal

Unless otherwise stated in the Installation and Maintenance Instructions, this product is recyclable and no ecological hazard is anticipated with its disposal providing due care is taken, except:

### Viton:

- Can be landfilled, when in compliance with National and Local regulations.
- Can be incinerated, but a scrubber must be used to remove Hydrogen Fluoride, which is evolved from the product and with compliance to National and Local regulations.
- Is insoluble in aquatic media.

### PTFE:

- Can only be disposed of by approved methods, not incineration.
- Keep PTFE waste in a separate container do not mix it with other rubbish, and consign it to a landfill site.

## 1.16 Returning products

Customers and stockists are reminded that under EC Health, Safety and Environment Law, when returning products to Spirax Sarco they must provide information on any hazards and the precautions to be taken due to contamination residues or mechanical damage which may present a health, safety or environmental risk. This information must be provided in writing including Health and Safety data sheets relating to any substances identified as hazardous or potentially hazardous.

## — 2. General product information —

### 2.1 General description

The AE30 automatic air eliminator/air vent range is designed for use on hot and cold water installations. The body and cap are of a special brass alloy which is dezincification resistant (DZR). The range is available as follows:

<b>AE30</b>	Standard air eliminator/air vent
<b>AE30A</b>	Standard air eliminator/air vent with check valve
* <b>AE30B</b>	Standard air eliminator/air vent with lockshield valve
* <b>AE30C</b>	Standard air eliminator/air vent with check valve and lockshield valve
** <b>AE30LV</b>	Standard air eliminator/air vent with a lightweight float
** <b>AE30LVA</b>	Standard air eliminator/air vent with a lightweight float and check valve

\* The fitted lockshield valve (versions **AE30B** and **AE30C**) has a unique 3-way locking system enabling the valve to be either locked open or locked closed or used as a conventional ball valve. Operation of the valve is by using a lockshield valve key which is available (at extra cost) from Spirax Sarco.

\*\* The lightweight float is suitable for use on liquids with a minimum specific gravity of 0.7 and has a Viton valve cone as standard for chemical resistance.

**Note:** For further information see the following Technical Information Sheets, TI-P017-07 and TI-P017-16.

### 2.2 Sizes and pipe connections

**AE30, AE30A, AE30LV and AE30LVA:** Inlet 1/2" female, Outlet 1/4" male both BSP or NPT

**AE30B and AE30C:** Inlet 1/2" male, Outlet 1/4" male both BSP

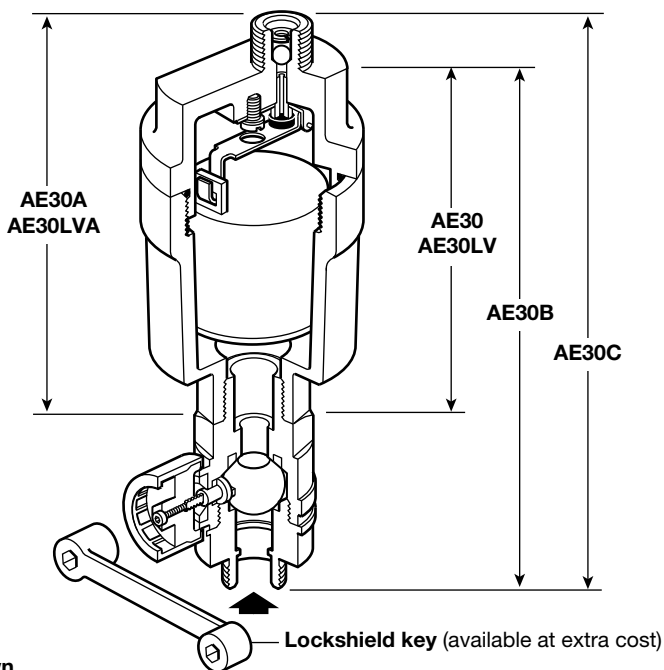
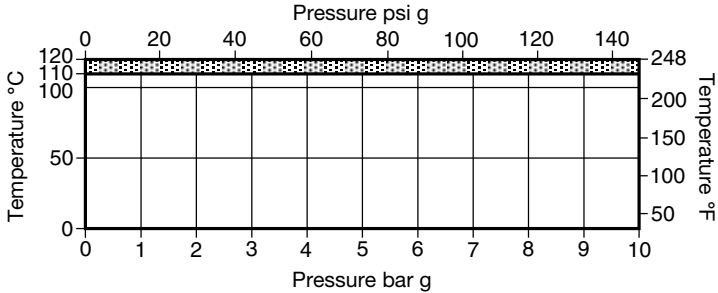



Fig. 1 AE30C shown

## 2.3 Pressure/temperature limits



 The product should not be used in this region as damage to the internals will occur.

Body design conditions	PN10	
PMA Maximum allowable pressure	10 bar g @ 120°C	(145 psi g @ 248°F)
TMA Maximum allowable temperature	120°C @ 10 bar g	(248°F @ 145 psi g)
Minimum allowable temperature	-10°C	(14°F)
PMO Maximum operating pressure	AE30	10 bar g @ 110°C (145 psi g @ 230°F)
	AE30LV	10 bar g @ 110°C (145 psi g @ 230°F)
TMO Maximum operating temperature (at all pressures)	110°C	(230°F)
ΔPMX Maximum differential pressure	AE30	8 bar g @ 110°C (116 psi g @ 230°F)
	AE30LV	3 bar g @ 110°C (43.5 psi g @ 230°F)
Minimum operating temperature	0°C	(32°F)
<b>Note:</b> For lower operating temperatures consult Spirax Sarco.		
Designed for a maximum cold hydraulic test pressure of:	15 bar g	(217 psi g)
<b>Minimum specific gravity of water</b>	AE30	<b>0.926</b>
<b>Minimum specific gravity of liquid</b>	AE30LV	<b>0.7</b>

---

## 3. Installation

---

**Note:** Before actioning any installation observe the 'Safety information' in Section 1.

Referring to the Installation and Maintenance Instructions, name-plate and Technical Information Sheet, check that the product is suitable for the intended installation:

- 3.1** Check materials, pressure and temperature and their maximum values. If the maximum operating limit of the product is lower than that of the system in which it is being fitted, ensure that a safety device is included in the system to prevent overpressurisation.
- 3.2** Determine the correct installation situation and the direction of fluid flow.
- 3.3** Remove protection covers from all connections and protective film from all name-plates, where appropriate, before installation on steam or other high temperature applications.
- 3.3** The automatic air eliminator/air vent should be installed vertically with the inlet at the bottom. We recommend piping the discharge from the air eliminator/air vent to a suitable safe point. To enable this to be done the outlet is provided with a ¼" BSP or NPT male thread. See Figure 2 for a typical application.

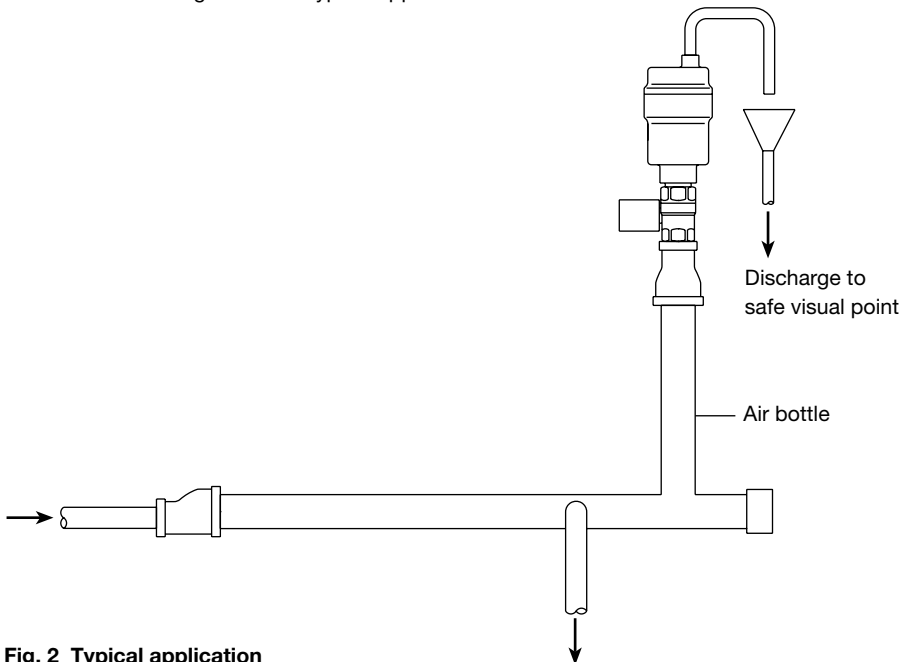

**Fig. 2 Typical application**

---

## 4. Commissioning

---

After installation or maintenance ensure that the system is fully functioning. Carry out tests on any alarms or protective devices.

---

## 5. Operation

---

At start-up the air eliminator/air vent is open allowing air to pass through the main valve. As soon as water reaches the vent the float is raised and the lever mechanism closes the valve. When more air reaches the vent it displaces water and the float falls thus opening the valve. After the air is discharged the valve is closed, as the water level rises to replace the air. The check valve is essential where there is a possibility of the system operating under negative head conditions. It will prevent air being drawn into the system. The lockshield valve is a standard ball valve fitted with a lockshield. It has a unique feature that offers 3 modes of operation:

- Normal operation.
- Locked in open position.
- Locked in closed position.

In normal operation the ball valve can be adjusted using a lockshield key.

In the open or closed position the valve can be locked. If the plastic cover and screw are removed the valve stem can be rotated to lock the ball valve in the open or closed position.

---

## 6. Maintenance

---

**Note: Before actioning any maintenance programme observe the 'Safety information' in Section 1.**

### 6.1 General information

All work must be carried out by a suitably competent person. Before starting work ensure that suitable tools are available. Use only Spirax Sarco replacement parts. Before attempting to work on the air vent ensure that it is isolated from the rest of the pressurised system. Allow time for the temperature of the air vent to normalise.

The unit has a long service life and the only maintenance that would normally be required is the occasional cleaning of the valve and seat.

### 6.2 How to clean/replace the valve and seat:

- Unscrew the cap from (1) the body.
- The float (4) can then be detached from the lever and the mechanism removed by undoing the screw (8) in the centre of the cap.
- The valve cone (5) is easily changed once the float has been removed.
- Refitting of the mechanism is straight forward, the float can then be hooked back onto the lever and the whole assembly screwed back into the body (see Table 1 for the recommended tightening torque).
- The set of internals are supplied with a check valve ball and circlip.
- The check valve is only required for the AE30A, AE30LVA and AE30C.
- The check valve should be fitted into the outlet port and held loosely by the circlip, which is fitted 1.6 mm below the level of the outlet as shown in Figure 3.

**After maintenance ensure that the system is fully functioning.**

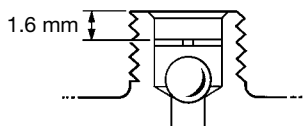

Fig. 3



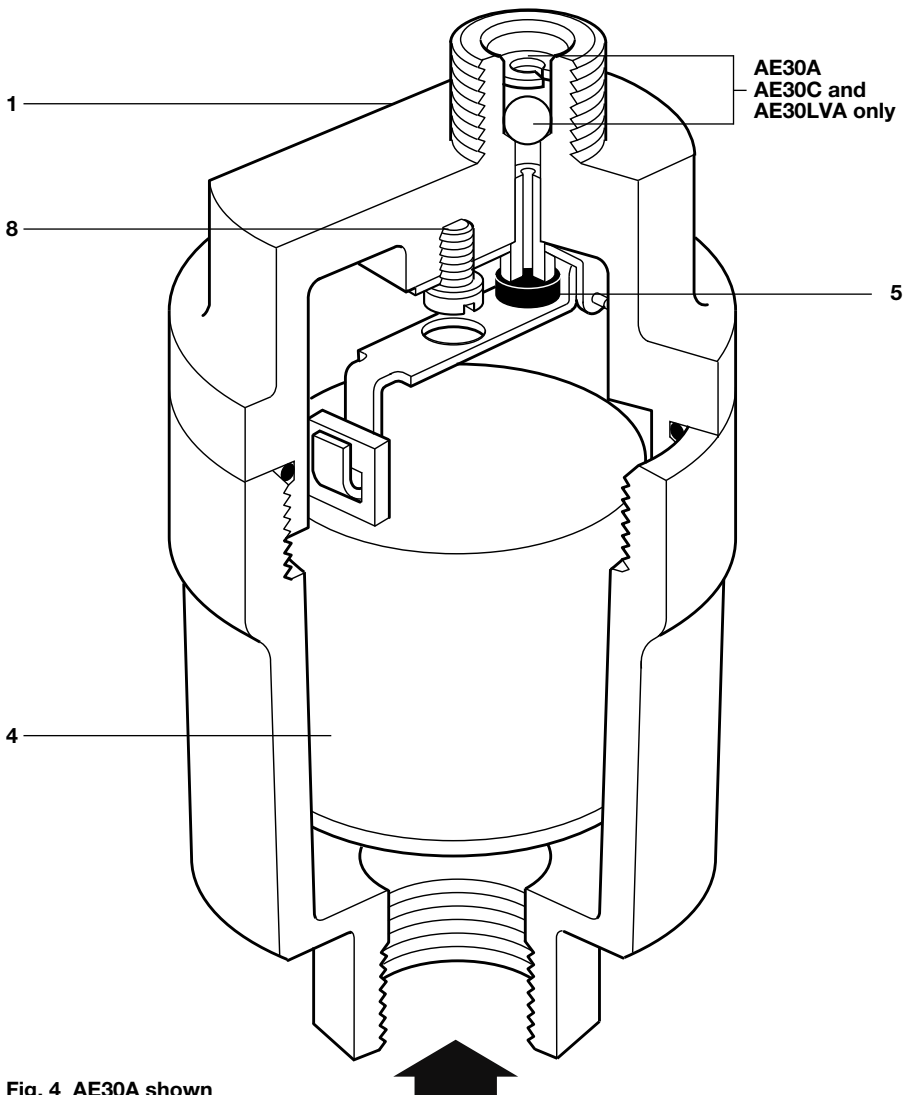



Fig. 4 AE30A shown

**Table 1 Recommended tightening torques**

Item No.		or mm		N m	(lbf ft)
1	30 A/F			10 - 12	(7.0 - 8.6)
8	Cheesehead		M4 x 6	2.5 - 2.8	(1.8 - 2.0)

---

## 7. Spare parts

---

The spare parts available are shown in solid outline. Parts drawn in broken lines are not supplied as spares.

### Available spares

---

Maintenance kit - comprising:

Cap 'O' ring, float, valve cone, check valve ball and check valve circlip.

---

**2, 4, 5, 9, 10**

### Important note

If you have earlier versions of the AE30 designated AE30 and AE30CV which operate over the range 0-3 bar then the spares set for the AE30, A, B and C can be used (but this will not convert it to operate over the range 0-8 bar). However, if you have the AE30H and AE30HCV which operate over the range 3-8 bar then the earlier spares set should be used.

### How to order spares

Always order spares by using the description given in the column headed 'Available spares' and state the size and type of automatic air eliminator/air vent.

**Example:** 1 - Maintenance kit for a ½" Spirax Sarco AE30A automatic air vent.

AE30A,  
AE30C and  
AE30LVA only

10  
9

5

4

2

AE30B and  
AE30C only

Fig. 5

