



Cert. No. LRQ 0963008

ISO 9001



TI-P358-25
CH Issue 3

AEL5系列电动执行器 用于DN15至DN100控制阀

简介

AEL5系列电动执行器为可反转式执行器, 具有线性输出。

可供型号

该系列执行器有四种电源输入型号, 230Vac, 115Vac, 24Vac和24Vdc, 标准型号接收VMD(阀电机驱动)信号, 如有需要则可安装内置定位板接收(4-20mA或2-10Vdc)控制信号, 24VDC不能加定位板。

执行器可选是否订购电位计, 订购电位计的执行器配有1kΩ反馈电阻作为标准配置, 它可以和接收4-20mA或2-10V的定位板配套使用, 或者作VMD输入信号的反馈, 其它可供配件包括辅助限位开关和防冷凝加热器, 详细参见TI-P358-28。

配以合适的阀门适配器和安装法兰, 该系列执行器可用于以下阀门。

2-通阀 SPIRA-TROL

3-通阀 QL33, QL43, QL63和QL73

注: 将执行器安装至阀门时, 需要安装法兰和阀门适配器, 见下表

安装法兰选择

阀门	执行器		
	AEL51_ AEL52_ AEL53_ AEL54_ AEL55_	AEL56_	
KE和KEA LE和LEA QL	DN15-DN50	EL5970	
LE和LEA	DN65-DN100	EL5971	
KE和KEA QL	DN65-DN100	EL5971	EL5972
JE和JEA	DN15-DN100	EL5971J	
	DN65-DN100	EL5972J	EL5972

阀门适配器选择

阀门类型和尺寸	阀杆	AEL51_	AEL52_	AEL53_	AEL54_	AEL55_	AEL56_
KE和KEA LE和LEA QL	DN15-DN50	M8螺纹	AEL6911	AEL6911	AEL6911	AEL6911	
	DN65-DN100	M12螺纹	集成	集成	集成	集成	EL5945
JE和JEA	DN15-DN50	M8螺纹	AEL6911J	AEL6911J	AEL6911J	AEL6911J	
	DN65-DN100	M12螺纹	AEL6912J	AEL6912J	AEL6912J	AEL6912J	EL5945

材质

序号	部件	材质	
1	外壳	1-8 KN	聚质酸脂
		14-25 KN	压铸铝
2	底座	压铸铝	

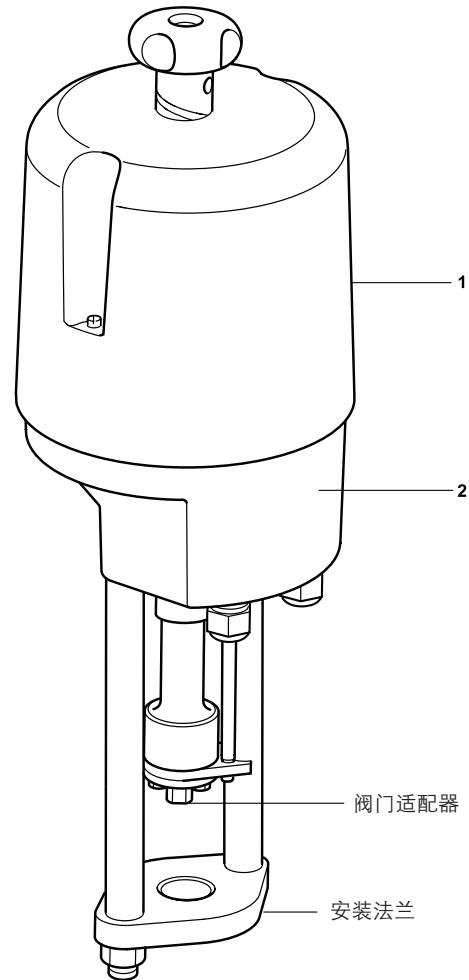

技术参数

型号	AEL51_	AEL52_	AEL53_	AEL54_	AEL55_	AEL56_
电源	230 Vac, 115 Vac, 24 Vac, (24 Vdc) ±10%					
电源频率Hz	50 Hz / 60 Hz / (连续)					
最大功耗VA	25.5 / 25.9 / (41)	37 / 40 / (24)	44 / 47 / (41)	72 / 68 / (41)	53 / 55 / (93)	100 / 86 / (NA)
最大行程	50	50	50	50	65	100
执行器速度mm/s	0.25 / 0.3 / (1)	0.5 / 0.6 / (0.5)	0.5 / 0.6 / (1)	0.65 / 0.78 / (0.5)	0.45 / 0.54 / (0.5)	1 / 1.2 / (1)
封装等级	IP65 (安装于室内外,应有足够的保护)					
最大推力kN	1	2	4.5	8	14	25
环境限制	-20- + 60°C (如装定位板-20 -+50°C)					
电机	同步电机(1-14 KN), 导步电容反转电机 (25KN) 或有刷直流电机(直流电源)					
端线	1.5 mm ²					
手动操作	手轮					
接线口	2×M20×1.5 (1-14 KN), 3×M20×1.5 (25 KN)					
定位板功耗VA	1					

* 功耗分别指50/60 Hz/(连续)

如需可调速度的执行器的请联系斯派莎克

认证

本产品具有 **CE** 钢印, 符合EN50081-1和EN50082-2(EMC), EN61010-1/A2(安全)标准92/31/EEC修正案89/336/EEC, 和93/68EEC(LVD)修正案93/68/EEC(EMC)和(72/73/EEC)。

**达到Class IV关闭的最大压差
KE, LE, KEA 和 LEA二通阀**

PTFE 或石墨阀杆密封

阀门尺寸		DN15	DN20	DN25	DN32	DN40	DN50	DN65	DN80	DN100									
Kv		4.0	6.3	10	16	25	36	63	100	160									
行程		20 mm						30 mm											
执行器	电压	最大压差 bar																	
		PTFE	石墨	PTFE	石墨	PTFE	石墨	PTFE	石墨	PTFE	石墨	PTFE	石墨	PTFE	石墨	PTFE	石墨	PTFE	石墨
AEL51211JX	230	29.7	14.8	22	10	12	4.8	10.3	4.2	2.6	-	1.2	-	-	-	-	-	-	-
AEL51212GX	115	29.7	14.8	22	10	12	4.8	10.3	4.2	2.6	-	1.2	-	-	-	-	-	-	-
AEL51213FX	24	29.7	14.8	22	10	12	4.8	10.3	4.2	2.6	-	1.2	-	-	-	-	-	-	-
AEL52211JX	230	40		40		39	31.8	30.7	24	11.4	8.8	7.5	5.6	3.2	1.4	1.5	0.3		-
AEL52212GX	115	40		40		39	31.8	30.7	24	11.4	8.8	7.5	5.6	3.2	1.4	1.5	0.3		-
AEL52213FX	24	40		40		39	31.8	30.7	24	11.4	8.8	7.5	5.6	3.2	1.4	1.5	0.3		-
AEL53211JX	230	-		40		40		40		33.5	30.8	23.2	21.3	12	10.2	7.1	6	4	3.3
AEL53212GX	115	-		40		40		40		33.5	30.8	23.2	21.3	12	10.2	7.1	6	4	3.3
AEL53213FX	24	-		40		40		40		33.5	30.8	23.2	21.3	12	10.2	7.1	6	4	3.3
AEL54211JX	230	-		-		-		40		40		40		24.4	22.6	15	13	8.9	8
AEL54212GX	115	-		-		-		40		40		40		24.4	22.6	15	13	8.9	8
AEL54213FX	24	-		-		-		40		40		40		24.4	22.6	15	13	8.9	8
AEL55311JX	230	-		-		-		-		40		40		40	40	28.7	27.5	17.4	16.7
AEL55312GX	115	-		-		-		-		40		40		40	40	28.7	27.5	17.4	16.7
AEL55313FX	24	-		-		-		-		40		40		40	40	28.7	27.5	17.4	16.7
AEL56411JX	230	-		-		-		-		-		-		40	40	40	40	32.9	32
AEL56412GX	115	-		-		-		-		-		-		40	40	40	40	32.9	32
AEL56413FX	24	-		-		-		-		-		-		40	40	40	40	32.9	32

波纹管密封(PTFE 或石墨阀杆密封)

阀门尺寸		DN15	DN20	DN25	DN32	DN40	DN50	DN65	DN80	DN100									
Kv		4.0	6.3	10	16	25	36	63	100	160									
行程		20 mm						30 mm											
执行器	电压	最大压差 bar																	
		PTFE	石墨	PTFE	石墨	PTFE	石墨	PTFE	石墨	PTFE	石墨	PTFE	石墨	PTFE	石墨	PTFE	石墨	PTFE	石墨
AEL52211JX	230	4.8	-	2.3	-	-	-	-	-	-	-	-	-	-	-	-	-	-	-
AEL52212GX	115	4.8	-	2.3	-	-	-	-	-	-	-	-	-	-	-	-	-	-	-
AEL52213FX	24	4.8	-	2.3	-	-	-	-	-	-	-	-	-	-	-	-	-	-	-
AEL53211JX	230	40		40		40		40		19.2	16.6	12.9	11	3.9	2.1	1.8	0.7	0.6	-
AEL53212GX	115	40		40		40		40		19.2	16.6	12.9	11	3.9	2.1	1.8	0.7	0.6	-
AEL53213FX	24	40		40		40		40		19.2	16.6	12.9	11	3.9	2.1	1.8	0.7	0.6	-
AEL54211JX	230	-		-		-		40		40		34.9	33	16.3	14.5	9.8	8.6	5.5	4.8
AEL54212GX	115	-		-		-		40		40		34.9	33	16.3	14.5	9.8	8.6	5.5	4.8
AEL54213FX	24	-		-		-		40		40		34.9	33	16.3	14.5	9.8	8.6	5.5	4.8
AEL55311JX	230	-		-		-		-		40		40		37.6	35.8	23.4	22.2	14.1	13.3
AEL55312GX	115	-		-		-		-		40		40		37.6	35.8	23.4	22.2	14.1	13.3
AEL55313FX	24	-		-		-		-		40		40		37.6	35.8	23.4	22.2	14.1	13.3
AEL56411JX	230	-		-		-		-		-		-		40		40		29.5	28.8
AEL56412GX	115	-		-		-		-		-		-		40		40		29.5	28.8
AEL56413FX	24	-		-		-		-		-		-		40		40		29.5	28.8

**达到Class VI关闭的最大压差(仅对于PTFE(G)阀座密封
KE, LE, KEA 和 LEA 二通阀)**

PTFE 或石墨阀杆密封

阀门尺寸		DN15	DN20	DN25	DN32	DN40	DN50	DN65	DN80	DN100									
Kv		4.0	6.3	10	16	25	36	63	100	160									
行程		20 mm						30 mm											
执行器	电压	最大压差 bar																	
		PTFE	石墨	PTFE	石墨	PTFE	石墨	PTFE	石墨	PTFE	石墨	PTFE	石墨	PTFE	石墨	PTFE	石墨	PTFE	石墨
AEL51211JX	230	40	29.7	35	23.2	23	15.5	18	11.9	7.7	5.1	5.5	3.6	2.9	1.1	-	-	-	-
AEL51212GX	115	40	29.7	35	23.2	23	15.5	18	11.9	7.7	5.1	5.5	3.6	2.9	1.1	-	-	-	-
AEL51213FX	24	40	29.7	35	23.2	23	15.5	18	11.9	7.7	5.1	5.5	3.6	2.9	1.1	-	-	-	-
AEL52211JX	230	40	40	40	40	40	38.4	32.3	16.6	13.9	11	9.9	6.4	4.6	4.1	2.9	2.5	1.8	1.8
AEL52212GX	115	40	40	40	40	40	38.4	32.3	16.6	13.9	11	9.9	6.4	4.6	4.1	2.9	2.5	1.8	1.8
AEL52213FX	24	40	40	40	40	40	38.4	32.3	16.6	13.9	11	9.9	6.4	4.6	4.1	2.9	2.5	1.8	1.8
AEL53211JX	230	-	-	-	40	40	40	38.6	35.9	27	25.6	15.2	13.4	9.7	8.6	6	5.3	5.3	5.3
AEL53212GX	115	-	-	-	40	40	40	38.6	35.9	27	25.6	15.2	13.4	9.7	8.6	6	5.3	5.3	5.3
AEL53213FX	24	-	-	-	40	40	40	38.6	35.9	27	25.6	15.2	13.4	9.7	8.6	6	5.3	5.3	5.3
AEL54211JX	230	-	-	-	-	40	40	40	40	40	40	27.6	25.8	17.6	16.5	11	10.2	10.2	10.2
AEL54212GX	115	-	-	-	-	40	40	40	40	40	40	27.6	25.8	17.6	16.5	11	10.2	10.2	10.2
AEL54213FX	24	-	-	-	-	40	40	40	40	40	40	27.6	25.8	17.6	16.5	11	10.2	10.2	10.2
AEL55311JX	230	-	-	-	-	-	-	-	40	40	40	40	31.3	30.1	19.5	18.8	18.8	18.8	18.8
AEL55312GX	115	-	-	-	-	-	-	-	40	40	40	40	31.3	30.1	19.5	18.8	18.8	18.8	18.8
AEL55313FX	24	-	-	-	-	-	-	-	40	40	40	40	31.3	30.1	19.5	18.8	18.8	18.8	18.8
AEL56411JX	230	-	-	-	-	-	-	-	-	40	40	40	40	40	40	40	40	40	40
AEL56412GX	115	-	-	-	-	-	-	-	-	-	-	40	40	40	40	40	40	40	40
AEL56413FX	24	-	-	-	-	-	-	-	-	-	-	-	40	40	40	40	40	40	40

波纹管密封(PTFE 或石墨阀杆密封)

阀门尺寸		DN15	DN20	DN25	DN32	DN40	DN50	DN65	DN80	DN100									
Kv		4.0	6.3	10	16	25	36	63	100	160									
行程		20 mm						30 mm											
执行器	电压	最大压差 bar																	
		PTFE	石墨	PTFE	石墨	PTFE	石墨	PTFE	石墨	PTFE	石墨	PTFE	石墨	PTFE	石墨	PTFE	石墨	PTFE	石墨
AEL52211JX	230	19.8	4.9	15.7	3.9	10.5	2.6	8.1	2	2.5	0.6	-	-	-	-	-	-	-	-
AEL52212GX	115	19.8	4.9	15.7	3.9	10.5	2.6	8.1	2	2.5	0.6	-	-	-	-	-	-	-	-
AEL52213FX	24	19.8	4.9	15.7	3.9	10.5	2.6	8.1	2	2.5	0.6	-	-	-	-	-	-	-	-
AEL53211JX	230	40	40	40	40	40	40	25.5	22.9	18.2	16.3	7.9	6.1	5	3.9	3.1	2.4	2.4	2.4
AEL53212GX	115	40	40	40	40	40	40	25.5	22.9	18.2	16.3	7.9	6.1	5	3.9	3.1	2.4	2.4	2.4
AEL53213FX	24	40	40	40	40	40	40	25.5	22.9	18.2	16.3	7.9	6.1	5	3.9	3.1	2.4	2.4	2.4
AEL54211JX	230	-	-	-	-	40	40	40	40	38.3	20.3	18.5	13	11.8	8.1	7.3	7.3	7.3	7.3
AEL54212GX	115	-	-	-	-	40	40	40	40	38.3	20.3	18.5	13	11.8	8.1	7.3	7.3	7.3	7.3
AEL54213FX	24	-	-	-	-	40	40	40	40	38.3	20.3	18.5	13	11.8	8.1	7.3	7.3	7.3	7.3
AEL55311JX	230	-	-	-	-	-	-	-	40	40	39.7	26.5	25.4	16.5	15.8	15.8	15.8	15.8	15.8
AEL55312GX	115	-	-	-	-	-	-	-	40	40	39.7	26.5	25.4	16.5	15.8	15.8	15.8	15.8	15.8
AEL55313FX	24	-	-	-	-	-	-	-	40	40	39.7	26.5	25.4	16.5	15.8	15.8	15.8	15.8	15.8
AEL56411JX	230	-	-	-	-	-	-	-	40	40	40	40	40	32.1	31.3	31.3	31.3	31.3	31.3
AEL56412GX	115	-	-	-	-	-	-	-	40	40	40	40	40	32.1	31.3	31.3	31.3	31.3	31.3
AEL56413FX	24	-	-	-	-	-	-	-	40	40	40	40	40	32.1	31.3	31.3	31.3	31.3	31.3

达到Class IV关闭的最大压差

JE和JEA二通阀

PTFE 或石墨阀杆密封

阀门尺寸		DN15	DN20	DN25	DN32	DN40	DN50	DN65	DN80	DN100									
		½"	¾"	1"	1¼"	1½"	2"	2½"	3"	4"									
Kv		4.0	6.3	10	16	25	36	63	100	160									
执行器	电压	最大压差 bar																	
		PTFE	石墨	PTFE	石墨	PTFE	石墨	PTFE	石墨	PTFE	石墨	PTFE	石墨	PTFE	石墨	PTFE	石墨	PTFE	石墨
AEL52211JX	24	79.5	64.6	61.3	49.5	39.1	31.2	30.7	24.6	11.5	8.8	7.5	5.6	3.2	1.4	1.5	0.4	0.5	
AEL52212GX	115	79.5	64.6	61.3	49.5	39.1	31.2	30.7	24.6	11.5	8.8	7.5	5.6	3.2	1.4	1.5	0.4	0.5	
AEL52213FX	24	79.5	64.6	61.3	49.5	39.1	31.2	30.7	24.6	11.5	8.8	7.5	5.6	3.2	1.4	1.5	0.4	0.5	
AEL53211JX	230			100	100	100	96.9	81.6	75.5	33.5	30.9	23.2	21.3	12.1	10.2	7.2	6.0	4.0	3.3
AEL53212GX	115			100	100	100	96.9	81.6	75.5	33.5	30.9	23.2	21.3	12.1	10.2	7.2	6.0	4.0	3.3
AEL53213FX	24			100	100	100	96.9	81.6	75.5	33.5	30.9	23.2	21.3	12.1	10.2	7.2	6.0	4.0	3.3
AEL54211JX	230							100	100	64.4	61.7	45.2	43.3	24.4	22.6	15.1	13.9	9.0	8.2
AEL54212GX	115							100	100	64.4	61.7	45.2	43.3	24.4	22.6	15.1	13.9	9.0	8.2
AEL54213FX	24							100	100	64.4	61.7	45.2	43.3	24.4	22.6	15.1	13.9	9.0	8.2
AEL55211JX	230									100	100	83.0	81.1	45.7	43.8	28.7	27.5	17.4	16.7
AEL55212GX	115									100	100	83.0	81.1	45.7	43.8	28.7	27.5	17.4	16.7
AEL55213FX	24									100	100	83.0	81.1	45.7	43.8	28.7	27.5	17.4	16.7
AEL56211JX	230											100	100	84.6	82.8	53.6	52.4	33.0	32.2
AEL56212GX	115											100	100	84.6	82.8	53.6	52.4	33.0	32.2
AEL56213FX	24											100	100	84.6	82.8	53.6	52.4	33.0	32.2

达到Class VI关闭的最大压差

JE和JEA二通阀

PTFE 或石墨阀杆密封

阀门尺寸		DN15	DN20	DN25	DN32	DN40	DN50	DN65	DN80	DN100									
		½"	¾"	1"	1¼"	1½"	2"	2½"	3"	4"									
Kv		4.0	6.3	10	16	25	36	63	100	160									
执行器	电压	最大压差 bar																	
		PTFE	石墨	PTFE	石墨	PTFE	石墨	PTFE	石墨	PTFE	石墨	PTFE	石墨	PTFE	石墨	PTFE	石墨	PTFE	石墨
AEL52211JX	115	94.1	79.2	74.3	62.5	49.7	41.8	38.5	32.4	16.6	14.0	11.8	9.9	6.4	4.6	4.1	3.0	2.5	1.8
AEL52212GX	115	94.1	79.2	74.3	62.5	49.7	41.8	38.5	32.4	16.6	14.0	11.8	9.9	6.4	4.6	4.1	3.0	2.5	1.8
AEL52213FX	24	94.1	79.2	74.3	62.5	49.7	41.8	38.5	32.4	16.6	14.0	11.8	9.9	6.4	4.6	4.1	3.0	2.5	1.8
AEL53211JX	230			100	100	100	100	89.4	83.3	38.6	36.0	27.5	25.6	15.3	13.5	9.8	8.6	6.1	5.4
AEL53212GX	115			100	100	100	100	89.4	83.3	38.6	36.0	27.5	25.6	15.3	13.5	9.8	8.6	6.1	5.4
AEL53213FX	24			100	100	100	100	89.4	83.3	38.6	36.0	27.5	25.6	15.3	13.5	9.8	8.6	6.1	5.4
AEL54211JX	230							100	100	69.5	66.9	49.5	47.7	27.7	25.9	17.7	16.5	11.0	10.3
AEL54212GX	115							100	100	69.5	66.9	49.5	47.7	27.7	25.9	17.7	16.5	11.0	10.3
AEL54213FX	24							100	100	69.5	66.9	49.5	47.7	27.7	25.9	17.7	16.5	11.0	10.3
AEL55211JX	230									100	100	87.3	85.4	48.9	47.1	31.3	30.1	19.5	18.8
AEL55212GX	115									100	100	87.3	85.4	48.9	47.1	31.3	30.1	19.5	18.8
AEL55213FX	24									100	100	87.3	85.4	48.9	47.1	31.3	30.1	19.5	18.8
AEL56211JX	230											100	100	87.8	86.0	56.2	55.0	35.0	34.3
AEL56212GX	115											100	100	87.8	86.0	56.2	55.0	35.0	34.3
AEL56213FX	24											100	100	87.8	86.0	56.2	55.0	35.0	34.3

仅用于调节控制中的最大压差

QL三通阀

PTFE 或石墨阀杆密封

阀门尺寸		DN15	DN20	DN25	DN32	DN40	DN50	DN65	DN80	DN100									
Kv		4.0	6.3	10	16	25	36	63	100	160									
行程		20 mm						30 mm											
执行器	电压	最大压差 bar																	
		PTFE	石墨	PTFE	石墨	PTFE	石墨	PTFE	石墨	PTFE	石墨	PTFE	石墨	PTFE	石墨	PTFE	石墨		
AEL51211JX	230	26.6	12	26.6	12	15.3	6.4	9.2	3.7	5.6	2	3.2	1	1.1	-	0.4	-	0.1	-
AEL51212GX	115	26.6	12	26.6	12	15.3	6.4	9.2	3.7	5.6	2	3.2	1	1.1	-	0.4	-	0.1	-
AEL51213FX	24	26.6	12	26.6	12	15.3	6.4	9.2	3.7	5.6	2	3.2	1	1.1	-	0.4	-	0.1	-
AEL52211JX	230	40	39.6	40	39.6	32.1	23.2	19.5	14	12.3	8.8	7.4	5.2	3.7	2.3	2.3	1.3	1.1	0.6
AEL52212GX	115	40	39.6	40	39.6	32.1	23.2	19.5	14	12.3	8.8	7.4	5.2	3.7	2.3	2.3	1.3	1.1	0.6
AEL52213FX	24	40	39.6	40	39.6	32.1	23.2	19.5	14	12.3	8.8	7.4	5.2	3.7	2.3	2.3	1.3	1.1	0.6
AEL53211JX	230	40	40	40	40	40	40	29.2	25.7	17.9	15.7	10.3	8.9	7	6	3.7	3.2		
AEL53212GX	115	40	40	40	40	40	40	29.2	25.7	17.9	15.7	10.3	8.9	7	6	3.7	3.2		
AEL53213FX	24	40	40	40	40	40	40	29.2	25.7	17.9	15.7	10.3	8.9	7	6	3.7	3.2		
AEL54211JX	230	-	-	-	-	-	-	40	32.6	30.3	19.6	18.2	13.5	12.5	7.4	6.9			
AEL54212GX	115	-	-	-	-	-	-	40	32.6	30.3	19.6	18.2	13.5	12.5	7.4	6.9			
AEL54213FX	24	-	-	-	-	-	-	40	32.6	30.3	19.6	18.2	13.5	12.5	7.4	6.9			
AEL55311JX	230	-	-	-	-	-	-	40	30.2	28.8	20.9	20	11.6	11.1					
AEL55312GX	115	-	-	-	-	-	-	40	30.2	28.8	20.9	20	11.6	11.1					
AEL55313FX	24	-	-	-	-	-	-	40	30.2	28.8	20.9	20	11.6	11.1					
AEL56411JX	230	-	-	-	-	-	-	-	40	40	25.3	24.7							
AEL56412GX	115	-	-	-	-	-	-	-	40	40	25.3	24.7							
AEL56413FX	24	-	-	-	-	-	-	-	40	40	25.3	24.7							

尺寸和重量 (近似) mm 和 kg

型号	A	B	C	重量
AEL51_	460	177	138	4.5
AEL52_	460	177	138	4.8
AEL53_	460	177	138	5.2
AEL54_	506	177	150	7.0
AEL55_	569	225	231	10.0
AEL56_	807	227	280	20.0

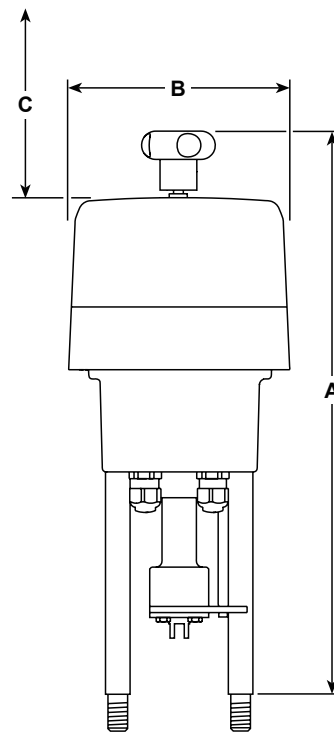

命名特征

命名特征	命名
产品	A=执行器
类型	E=电动
动作	L=线性
系列	5
推力(KN)	1=1KN
	2=2KN
	3=4.5KN
	4=8KN
	5=14KN
	6=25KN
行程(mm)	2=50mm(AEL51_、AEL52_、AEL53_、AEL54_系列)
	3=65mm(AEL55_系列)
	4=100mm(AEL56_系列)
最大速度(mm/s)	1=0-1.0mm/s
电源	1=230 Vac
	2=115 Vac
	3=24 Vac
	4=24 Vdc(AEL56_不提供)
控制信号*	F=24V VMD
	G=115V VMD
	J=230V VMD
故障模式	X=无故障保护装置
电位计	A=带1K Ω 电位计
	S= 不带

*对于0/2-10V,4-20mA控制的阀门, 需选择订购定位板

选型实例

控制阀	DN20 KE43 PTSUSS.2 Kv6.3 PN40	DN65 KE43 PTSUSS.2 Kv63 PN40
最大 ΔP	20 bar	20 bar
电源	230Vac	230Vac
控制信号	4-20mA	4-20mA
所选执行器	AEL51211JXA	AEL54211JXA
定位板	AEL5961	AEL5961
阀适配器	AEL6911	无
安装法兰	EL5970	EL5971