

P-Line heat exchanger

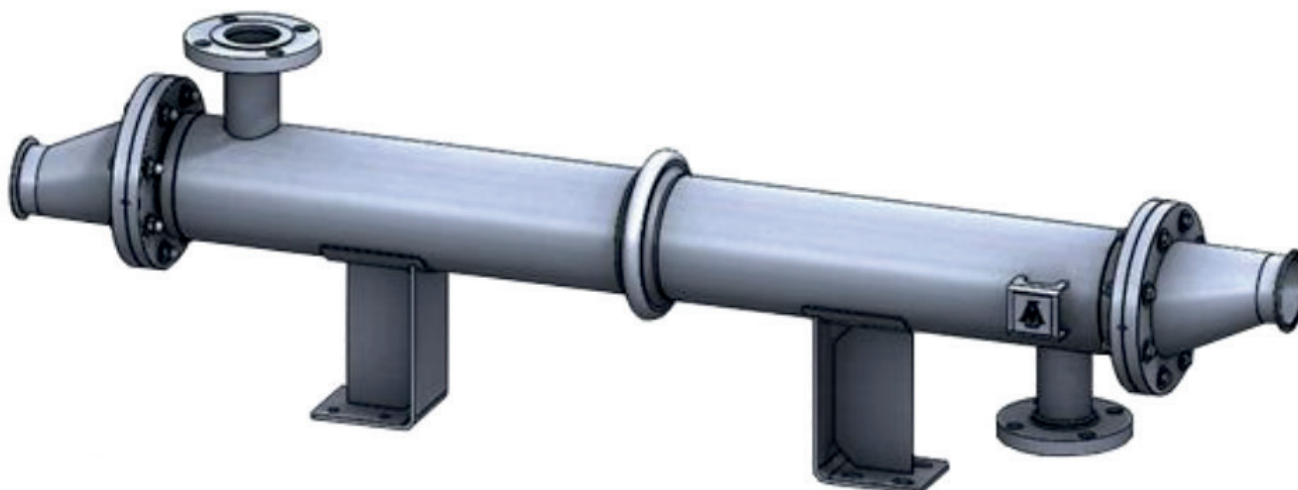

Description

P-line heat exchangers meet the highest requirements of the pharmaceutical industry. At the same time, they meet its stringent hygiene standards imposed by inspection bodies. They have been designed to minimize the risk of contamination and to ensure safe and sterile work. Tubes are connected to the tube sheets with pressure expanding method in which clean water under pressure up to 6000 bar is used. This eliminates the risk of damaging the internal surface of the tubes. Stainless straight tubes with a diameter of 8 mm (0.315") or 12.7 mm (0.5").

Certified Viton gaskets and triclamps, the clean side connections, in compliance with 3-A and American Food and Drug Administration FDA. Expanded tubes are then welded to the external tube sheet with orbital using welding a pure argon shield method.

Safety information, installation and maintenance

Full details are contained in the SP7-10 digital positioner Installation and Maintenance Instructions.

Applications

- Clean steam generation
- WFI generation
- WFI storage and distribution systems
- WFI point of use
- Food industry
- Dairy industry
- Brewing industry

Materials

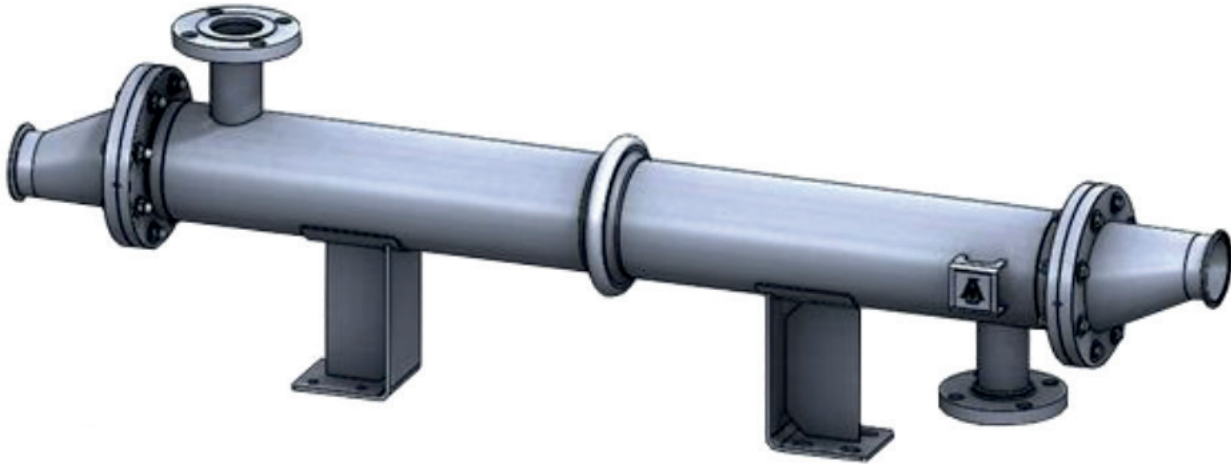

Part	Material	Finish
Shell	Stainless steel	316L (1.4404), polished mechanically, chemically etched and passivated
Tubes	Stainless steel	316L (1.4404), polished mechanically, chemically etched and passivated
Gasket	Viton	

Note

All surfaces in contact with the clean medium (e.g. internal surface of tubes, heads, etc.) electropolished to $Ra \leq 0,5 \mu m$ (20 μin)

Technical data

Tubes	Pressure rating	Maximum - 1 MPa (145 psi)
	Temperature rating (Viton gasket)	Maximum - 140 °C (284 °F) Minimum - -17 °C* (1.4 °F*)

*Parameters for P-050: min. temp. (Viton) -25 °C (-13 °F).

Shell	Pressure rating	Maximum - 1 MPa (145 psi)
	Temperature rating	Maximum - 200 °C (392 °F) Minimum - -25 °C (13 °F)

Technical drawing	Standard location of connections	K4/K1 - inlet /outlet tube side (hygienic side)
		K2/K3 -inlet /outlet shell side (service side)

Dimensions (approximate) in mm

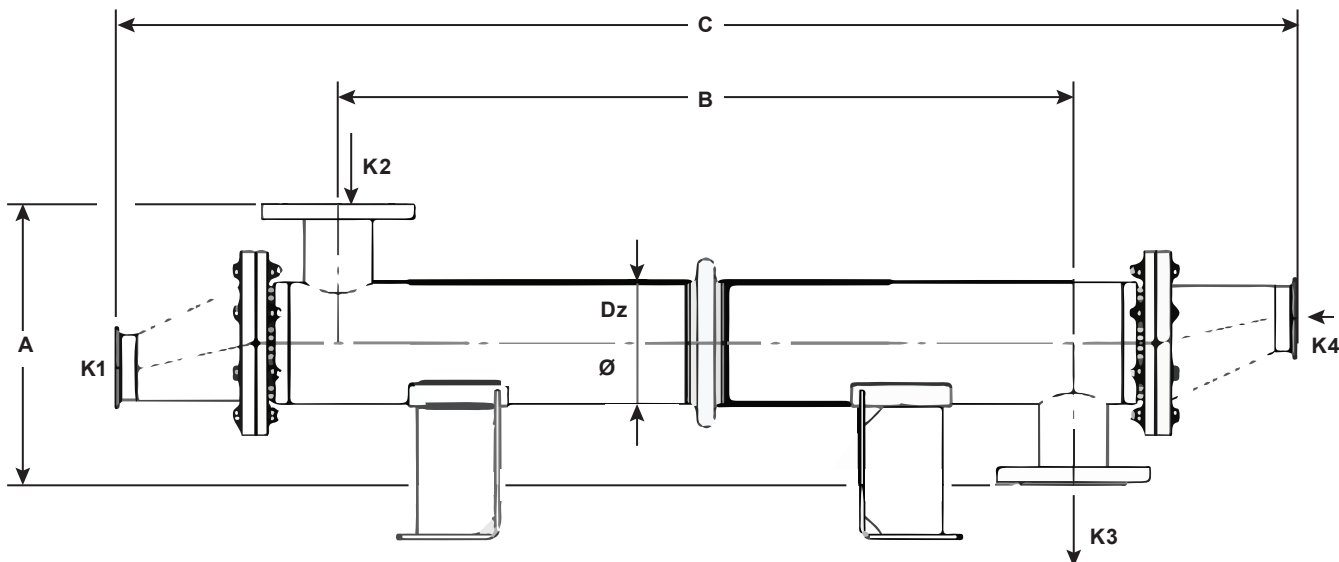

Type	A		B		C						ØDz	
	mm	in	mm	in	TYPE IP		TYPE2P		TYPE4P		mm	in
					mm	in	mm	in	mm	in		
P-050.070.08	176	6.93	709	27.91	880	34.65					60.3	2.37
P-050.110.08	176	6.93	1009	39.72	1180	46.46					60.3	2.37
P-050.140.08	176	6.93	1309	51.54	1480	58.27					60.3	2.37
P-080.070.08	300	11.81	518	20.39	1005	39.57					88.9	3.50
P-080.110.08	300	11.81	958	37.72	1445	56.89					88.9	3.50
P-080.140.08	300	11.81	1258	49.53	1745	68.70					88.9	3.50
P-100.070.08	325	12.80	518	20.39	1063	41.85					114.3	4.50
P-100.110.08	325	12.80	958	37.72	1503	59.17					114.3	4.50
P-100.140.08	325	12.80	1258	49.53	1803	70.98					114.3	4.50
P-125.110.08	350	13.78	958	37.72	1495	58.86	1294	50.95			139.7	5.50
P-125.140.08	350	13.78	1258	49.53	1795	70.67	1594	62.76			139.7	5.50
P-125.190.08	350	13.78	1728	68.03	2265	89.17	2064	81.26			139.7	5.50
P-150.110.08	370	14.57	960	37.80	1577	62.09	1268.5	49.94			159	6.26
P-150.140.08	370	14.57	1260	49.61	1877	73.90	1568.5	61.75			159	6.26
P-150.190.08	370	14.57	1730	68.11	2347	92.40	2038.5	80.26			159	6.26
P-200.110.08	460	18.11	924	36.38	1819	71.61	1272.5	50.10	1272.5	50.10	219.1	8.63
P-200.140.08	460	18.11	1224	48.19	2119	83.43	1572.5	61.91	1572.5	61.91	219.1	8.63
P-200.190.08	460	18.11	1694	66.69	2589	101.93	2042.5	80.41	2042.5	80.41	219.1	8.63
P-250.110.08	555	21.85	926	36.46	1962	77.24	1297.5	51.08	1297.5	51.08	273	10.75
P-250.140.08	555	21.85	1226	48.27	2262	89.06	1597.5	62.89	1597.5	62.89	273	10.75
P-250.190.08	555	21.85	1696	66.77	2732	107.56	2067.5	81.40	2067.5	81.40	273	10.75

Dimensions continued on next page

Dimensions (approximate) in mm (continued)

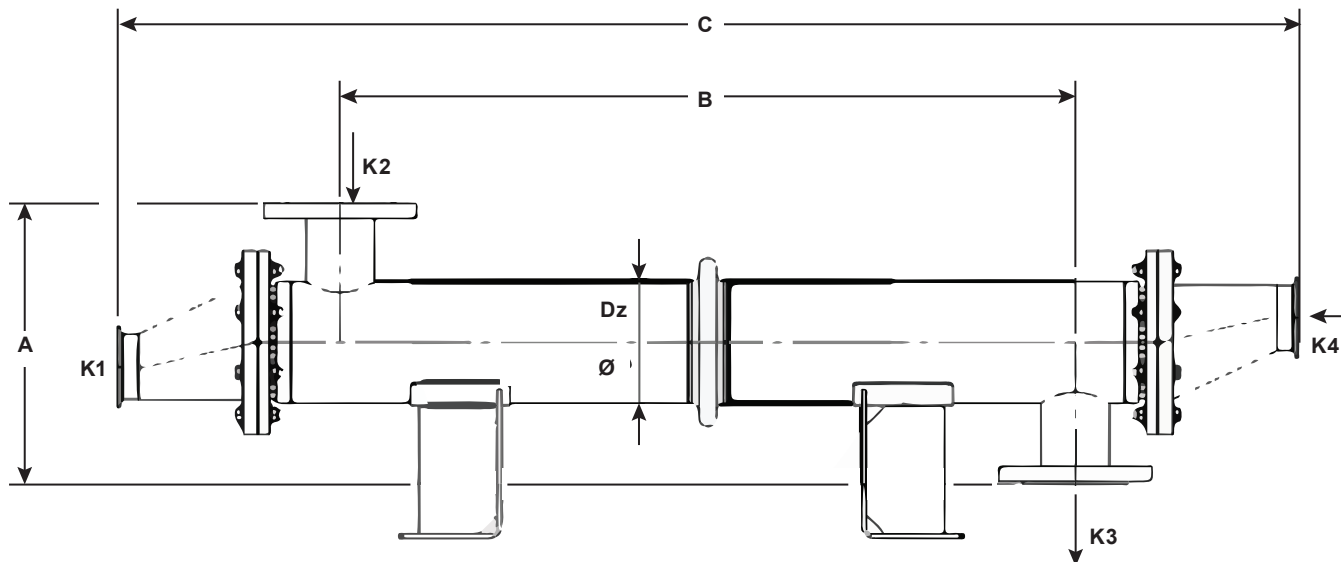

Type	A		B		C						ØDz	
	mm	in	mm	in	TYPE IP		TYPE2P		TYPE4P		mm	in
					mm	in	mm	in	mm	in		
P-050.070.12	176	6.93	709	27.91	880	34.65					60.3	2.37
P-050.110.12	176	6.93	1009	39.72	1180	46.46					60.3	2.37
P-050.140.12	176	6.93	1309	51.54	1480	58.27					60.3	2.37
P-080.070.12	300	11.81	518	20.39	1005	39.57					88.9	3.50
P-080.110.12	300	11.81	958	37.72	1445	56.89					88.9	3.50
P-080.140.12	300	11.81	1258	49.53	1745	68.70					88.9	3.50
P-100.070.12	325	12.80	518	20.39	1063	41.85					114.3	4.50
P-100.110.12	325	12.80	958	37.72	1503	59.17					114.3	4.50
P-100.140.12	325	12.80	1258	49.53	1803	70.98					114.3	4.50
P-125.110.12	350	13.78	958	37.72	1495	58.86	1294	50.95			139.7	5.50
P-125.140.12	350	13.78	1258	49.53	1795	70.67	1594	62.76			139.7	5.50
P-125.190.12	350	13.78	1728	68.03	2265	89.17	2064	81.26			139.7	5.50
P-150.110.12	370	14.57	960	37.80	1577	62.09	1268.5	49.94			159	6.26
P-150.140.12	370	14.57	1260	49.61	1877	73.90	1568.5	61.75			159	6.26
P-150.190.12	370	14.57	1730	68.11	2347	92.40	2038.5	80.26			159	6.26
P-200.110.12	460	18.11	924	36.38	1819	71.61	1272.5	50.10	1272.5	50.10	219.1	8.63
P-200.140.12	460	18.11	1224	48.19	2119	83.43	1572.5	61.91	1572.5	61.91	219.1	8.63
P-200.190.12	460	18.11	1694	66.69	2589	101.93	2042.5	80.41	2042.5	80.41	219.1	8.63
P-250.110.12	555	21.85	926	36.46	1962	77.24	1297.5	51.08	1297.5	51.08	273	10.75
P-250.140.12	555	21.85	1226	48.27	2262	89.06	1597.5	62.89	1597.5	62.89	273	10.75
P-250.190.12	555	21.85	1696	66.77	2732	107.56	2067.5	81.40	2067.5	81.40	273	10.75

Mounting

Horizontal mounting

1P heat exchanger

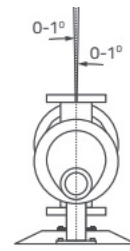
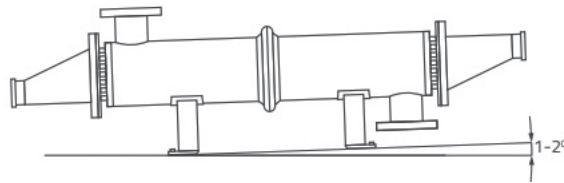

2P and 4P heat exchanger

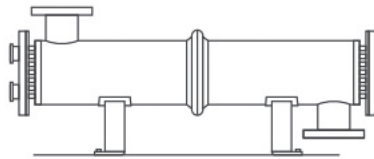

Vertical mounting

1P heat exchanger

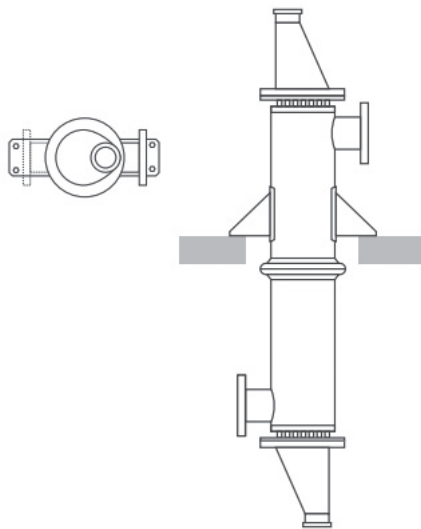

2P heat exchanger

