



Cert. No. LRQ 0963008

ISO 9001

# spirax/sarco

TI-P170-01  
MI Issue 4

## F50C Isolating Valve

### Description

The F50C is a needle type isolating valve designed for primary isolation in flowmetering applications with steam and other industrial fluids. No spares are available.

### Sizes and pipe connections

½" screwed NPT.

### Limiting conditions

Maximum operating pressure	413 bar g (6 000 psi g)
Maximum operating temperature	400°C (752°F)

### Operating range

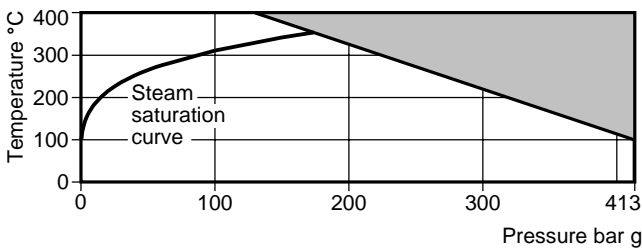

The product must not be used in this region.

### Materials

No.	Part	Material
1	Body	Carbon steel, zinc plated and passivated
2	Seals	Graphoil (not shown)

### K<sub>v</sub> values

0.474

For conversion:  $C_v$  (UK) =  $K_v \times 0.963$      $C_v$  (US) =  $K_v \times 1.156$

### Dimensions/weight (approximate) in mm and kg

A	B	C	Connections	Weight
66	28	76*	½" NPT	0.5

\*With valve open

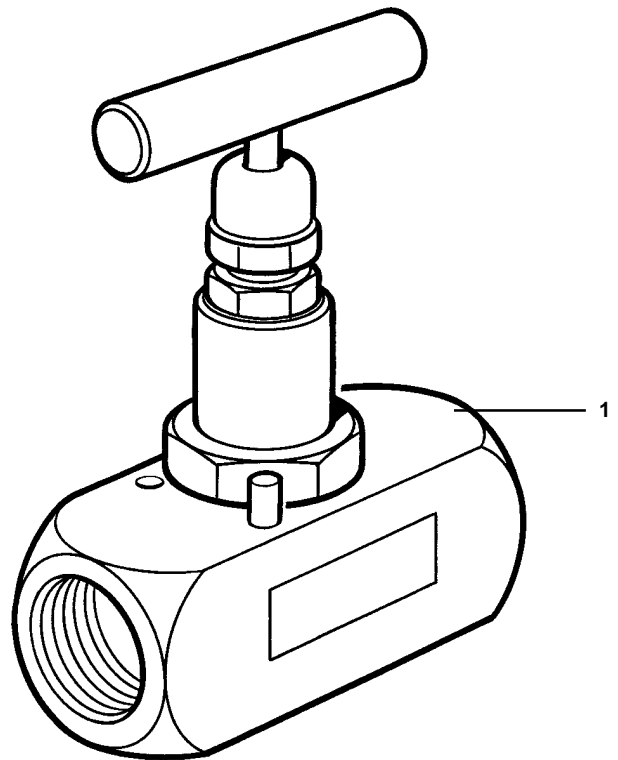
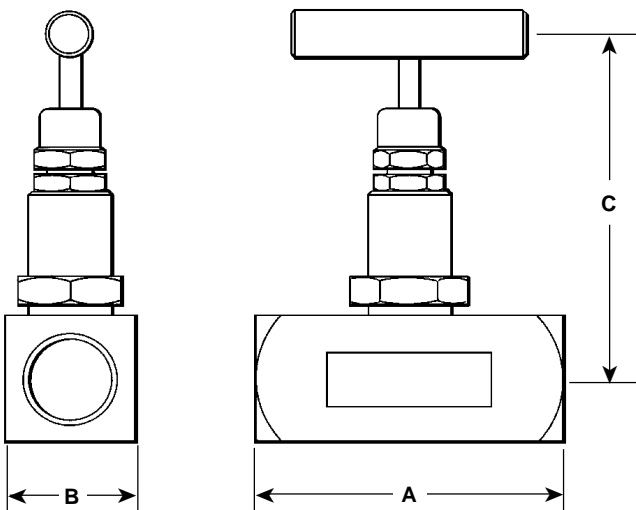

### Installation

#### Warning

This document does not give sufficient information to install the product in a safe manner. See the relevant system Installation and Maintenance Instructions for full details.

The F50C valve may be installed in any position, but the flow should be in the direction of the arrow on the valve body. When used as an isolating valve in a steam meter impulse line, it is important to install the valve on the centre line of the flowmeter rather than below it, so that the valve is in steam rather than water.

#### Safety

##### Warning

Your attention is drawn to Safety information leaflet IM-GCM-10.

### How to order

Example: 1 off Spirax Sarco F50C isolating valve.