

DAB Series - Desuperheater Installation and Maintenance Guide



- 1. Warranty*
- 2. General Safety Information*
- 3. Introduction*
- 4. Functioning Principle*
- 5. Specifications*
- 6. Storage*
- 7. Installation*
- 8. Maintenance*
- 9. Troubleshooting*

1. Warranty

Spirax Sarco warrants, subject to the conditions described below, to repair and replace without charge, including labor costs, any components which fail within 1 year of product delivery to the customer. Such failure must have occurred because of defect in material or manufacturing and not as a result of product not being used in accordance with the instructions of this manual.

This warranty does not apply to products which require repair or replacement due to normal wear out or products that are subject to accident, misuse or improper maintenance.

Spirax Sarco Hiter only obligation with Warranty is to repair or replace any product that we consider defective. Spirax Sarco Hiter reserves the right to inspect the product in customer installations or request the return of the product with freight prepaid by the buyer.

Spirax Sarco Hiter may replace or repair any parts that are deemed defective without further responsibilities. All repairs or services executed by Spirax Sarco Hiter, which are not covered by this warranty, will be charged according to the current price list.

THIS IS THE ONLY SPIRAX SARCO HITER WARRANTY TERM AND ONLY HEREBY SPIRAX SARCO HITER EXPRESS.BUYER DISCLAIMS ALL OTHER WARRANTIES IMPLIED BY LAW, INCLUDING ANY MARKET WARRANTY FOR A PARTICULAR PURPOSE.

— 2. *General Safety Information* —

Access

Ensure safe access and if necessary a safe working platform (suitably guarded) before attempting to work on the product. Arrange suitable lifting gear if required.

Lighting

Ensure adequate lighting, particularly where detailed or intricate work is required.

Hazardous liquids or gases in the pipeline

Consider what is in the pipeline or what may have been in the pipeline at some previous time. Consider; flammable materials, substances hazardous to health, extremes of temperature.

Hazardous environment around the product

Consider; explosion risk areas, lack of oxygen (e.g. tanks, pits), dangerous gases, extremes of temperature, hot surfaces, fire hazard (e.g. during welding), excessive noise, moving machinery.

The system

Consider the effect on the complete system of the work proposed. Will any proposed action (e.g. closing isolation valves, electrical isolation) put any other part of the system or any personnel at risk? Dangers might include isolation of vents or protective devices or the rendering ineffective of controls or alarms. Ensure isolation valves are turned on and off in a gradual way to avoid system shocks.

Pressure systems

Ensure that any pressure is isolated and safely vented to atmospheric pressure.

Consider double isolation (double block and bleed) and the locking or labeling of closed valves. Do not assume that the system has depressurized even when the pressure gauge indicates zero.

Temperature

Allow time for temperature to normalize after isolation to avoid danger of burns.

Tools and consumables

Before starting work ensure that you have suitable tools and/or consumables available. Use only genuine Spirax Sarco Hiter replacement parts.

Tools and consumables

Before starting work ensure that you have suitable tools and/or consumables available. Use only genuine Spirax Sarco Hiter replacement parts.

Protective clothing

Consider whether any protective clothing required by yourself and / or others in the vicinity to protect against the hazards of, for example, chemicals, high / low temperature, noise, falling objects, and dangers to eyes and face.

Permits to work

All work must be carried out or be supervised by a suitably competent person. Post 'warning notices' if necessary.

Electrical works

Before starting work study the wiring diagram and wiring instructions, and check any special requirements. Consider special emphasis on primary and phase source, local isolation of the major systems, fuse requirements, grounding, special cables, cable entries and electrical voltage selection.

Commissioning

After installation or maintenance, ensure that the system is working properly. Perform tests on all alarms and protective devices.

Storage

Equipment and materials shall be stored in a proper place and securely.

Disposal

Unless otherwise stated in the Installation and Maintenance Instructions, this product is recyclable and no ecological hazard is anticipated with its disposal providing due care is taken.

3. Introduction

The **DAB Series** desuperheater is designed with the purpose of efficiently reducing the steam temperature up to the required one.

The **DAB Series** desuperheater is also part of a steam line, including a distribution system (pipes) with nozzles connected to it. These nozzles are strategically positioned to obtain an ideal mixture and a rapid vaporization of the cooling water. The inlet of cooling water is controlled by a control valve.

The **DAB** desuperheater can be optionally supplied with an internal thermal jacket to protect the steam line.

4. Functioning Principle

The cooling water comes inside of the desuperheater and is distributed between the nozzles by the pipes of the distribution system. Each nozzle has a water injection orifice with variable hole sizes. The amount of water is controlled by a temperature control valve which responds to a signal generated by the thermal controller.

Inside the nozzle, the water flow assumes a rotational movement around the plug, due to the injection holes position. Due to the plug profile, the water flow accelerate up to the injection point. This acceleration of water flow improves the atomization efficiency and the rapid vaporization. The plug has a pre-load made by the spring which is adjusted with a nut.

The plug opening force is determined by the pressure differential between the cooling water and the steam or the stem outlet temperature.

The opening variation of the injection orifice gives the compensation of any load variation on the water control valve, assuring a perfect water atomization.

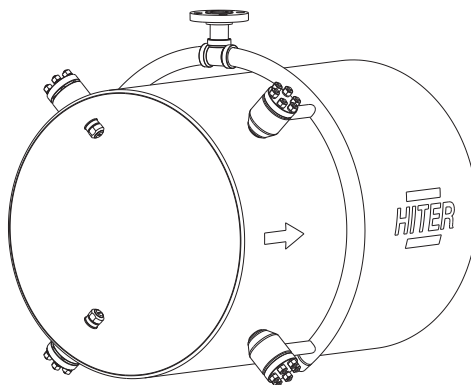

Figure 1 – DAB Series Desuperheater.

5. Specifications

- Pressure Classes: ASME 150 to 2500.
- Steam line size: 24" to 60". For different sizes, please consult Hiter.
- Nozzles: 1 to 7 nozzles with individual Cvs from 0,5 to 6,0.
- Differential pressure between steam and water: 1 to 21 bar (15 to 300psi).
- Injector orifice rangeability: Only limited by the water control valve rangeability.

6. Storage

DAB Series desuperheater is delivered in appropriate packing. Keep it in its own package and do not remove the protection plugs until it is being installed.

The equipment shall be stored in a clean and dry area. It is not recommended to keep this product in outside areas, but if it is inevitable, it should be placed over a wooden pallet which keep it away from the ground and protected against weather elements.

7. Installation

- Remove all the protections prior to installation.
- Install the desuperheater in the steam pipe.
- Clean and dry the water pipe prior to connecting it to the desuperheater.
- Minimum straight pipe distance upstream: 6 times the pipe diameter or 4 meter for pipes with diameter equals or higher than 700mm (28”).
- Minimum straight pipe distance downstream: 6 meters.
- Temperature sensor minimum distance for installation: 12 meters.

RECOMMENDATIONS:

Select the installation local carefully, this is very importante in the cases where the steam velocity is low and its temperature is close to the point of saturation. The minimum straight pipe distance up and downstream shall be straightly followed such as the minimum distance between the temperature sensor and the desuperheater.

To avoid the clogging of injection orifices by solid particles, shall be used a filter with 100-200 μ m mesh before the water control valve.

On the steam line there shall not be derivations or interferences such as gate valves, orifices plate or intersection of other lines between the desuperheater and the temperature sensor.

The recommended minimum distance for installing the temperature sensor is at least 12 meters downstream from the desuperheater.

There should be no leads or interferences such as drawer valve, orifice plate, intersection of other lines, in the vapor line between the dessuperheater and the temperature sensor.

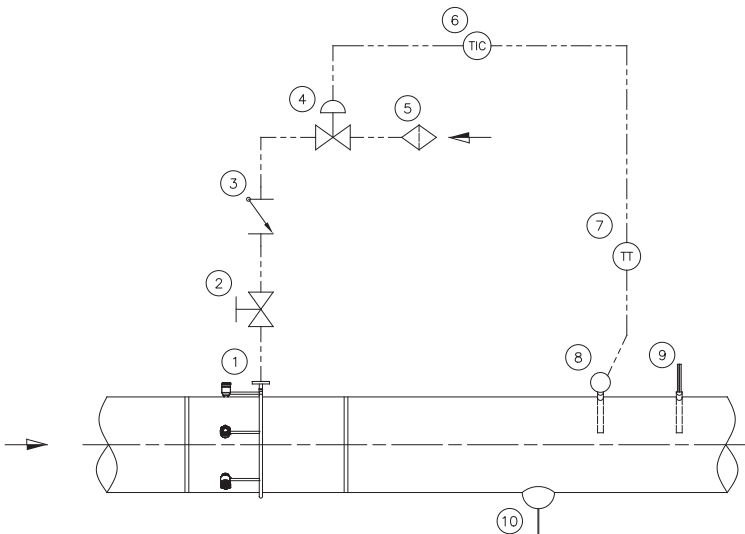

Figure 2 – Typical Installation

Typical Installation - Components

| | |
|----|--------------------------------------|
| 1 | DAB Desuperheater |
| 2 | Manual Block Valve |
| 3 | Check Valve |
| 4 | Temperature Control Valve |
| 5 | Strainer |
| 6 | Temperature Indicator and Controller |
| 7 | Temperature Transmitter |
| 8 | Temperature Sensor |
| 9 | Thermometer |
| 10 | Drain |

8. Maintenance

- DAB Series Desuperheater requires low maintenance. Just needed when occurs some clogging of the orifices of water injection.
- Prior to start the disassembly, relief the pressure inside the pipe lines, close the block valve for the cooling water.
- Loosen and remove the nuts (8).
- Remove the washers (7).
- Remove the cover (6).
- Remove a packing-retaining ring (5) and so the packings (4).
- Remove the injection nozzle set (3).
- Remove the gasket (2).
- The nozzle and the injector nozzle set shall be inspected and/or cleaned for reuse. Do not try to disassemble the injection nozzle set. Please contact Hiter Technical Assistance if there is need of repair in some part of injection nozzle set.
- Wash the desuperheater until it unclog.
- Proceed with the reinstallation, following the reverse order of disassembly.

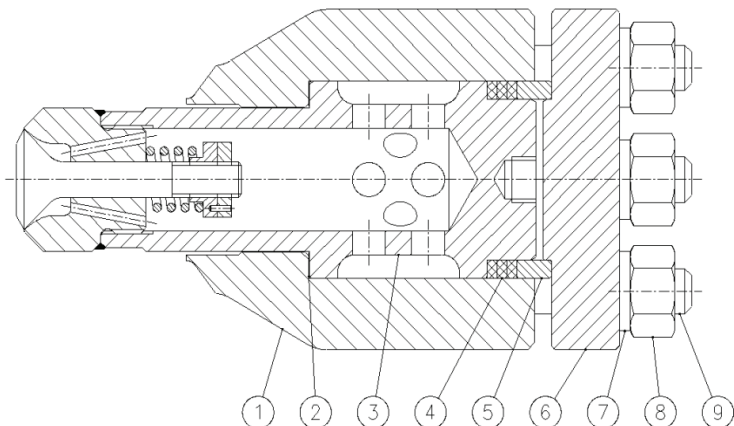

Figure 3 – Water Bocal de Injeção de Água

- | | |
|---------------------------|-----------|
| 1- Body | 6- Cover |
| 2- Gasket | 7- Washer |
| 3- Injection Nozzle Set | 8- Nut |
| 4- Packings | 9- Stud |
| 5- Packing-Retaining Ring | |

9. Troubleshooting

| Problem | Possible Case |
|---|--|
| Water in the steam line. | Verify if the steam traps are operating properly. |
| | Verify the upstream pipe design about corners/curves and Tees. |
| Water in the steam line when it is insulated. | Verify if there is leakage on the water control valve. |
| Wanted temperature not reached. | Verify if there is clog on the orifices. |
| | Verify the water pressure. |
| | Verify if the steam saturation pressure is equivalent to a temperature higher than the needed. |
| Temperature is under the needed. | Verify the position of the temperature sensor. |
| | Verify the temperature control mesh |
| Temperature oscillates around the adjusted. | Verify if the needed temperature is not too close to the saturation temperature. |
| | Verify system parameters adjust. |

If the problem persists, please contact Hiter Technical Assistance.

Spirax Sarco by Hiter
Headquarters and Factory

Av. Jerome Case, 2600 - Éden
Sorocaba - SP, 18087-220
Fone +55 (15) 3225-0330
vendas@br.hiter.com
www.hiter.com/en

